



YAMAHA

MUSIC PRODUCTION GUIDE

OFFICIAL NEWS GUIDE FROM YAMAHA & EASY SOUNDS FOR YAMAHA MUSIC PRODUCTION INSTRUMENTS

02|2016

Contents

MONTAGE

Music In Motion - Part 2	3
Free Kits for the Yamaha DTX700	19
Yamaha DTX Multi-12 & M12 Touch App Directly trigger Samples, Loops, and Playbacks from your iPad!	21
Sounds & Goodies	23
Imprint	40

MUSIC IN MOTION
MONTAGE

CREATE YOUR SOUND. ANY PLACE, ANY TIME

reface YC
COMBO ORGAN



reface DX
FM SYNTHESIZER



reface

reimagined interfaces of classic Yamaha keyboards



reface CS
ANALOG PHYSICAL MODELING SYNTHESIZER



reface CP
E-PIANO

 yamahasyths_official

 yamahasyths

 YamahaSynthsEU

EUROPE.YAMAHA.COM

 **YAMAHA**

MONTAGE

MUSIC IN MOTION



Yamaha's new flagship synthesizer MONTAGE makes some waves since its introduction at the Winter NAMM 2016 in Anaheim.

In the previous edition of the Music Production Guide we have expended 16 pages for the first part of our detailed introduction. In this issue still 15 pages are added.

Those who missed the start - the 2016-01 edition of the Music Production Guide can be downloaded here:

www.easysounds.eu/mpghistory/history_en.htm

We will continue with the "Motion Control" concept of real-time control. Super Knob, Motion Sequences, and Envelope Follower help to create a incredibly dynamic sound with MONTAGE. And with FM-X in MONTAGE FM synthesis comes back stronger than ever.

MOTION CONTROL

Motion Control Conceptual Diagram

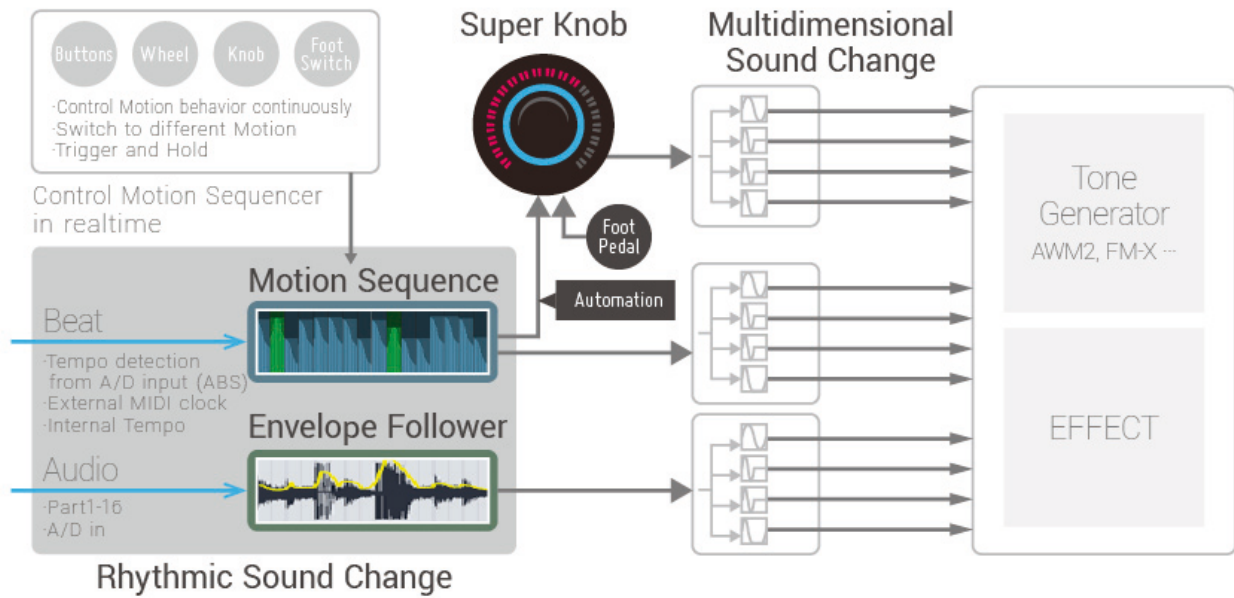

An outstanding feature of MONTAGE is Motion Control. It is comprised of the following components:

- *Super Knob*
- *Controllers*
- *Motion Sequence*
- *Arpeggio*
- *Envelope Follower*
- *Side Chain Modulation*

The figure "Outline of Motion Control" explains the complex interaction of the different components. Multidimensional sound changes affect the Tone Generator which can also process the sound with effects. All used components of Motion Control are running in sync with the Tempo and can even be controlled by external audio signals.

SUPER KNOB

The Super Knob is a completely new feature of MONTAGE, which automatically controls all Assignable Knobs of the Common Part simultaneously.

Accordingly, no parameters are assigned directly to the Super Knob. All assignments to the Assignable Knobs of the Common Part are effective for the Super Knob.

The Common Part himself can - if desired - make use of the parameter assignments made in the Parts. In the result there is a huge potential of parameters to choose from for the Super Knob.

The first step for programming the Super Knob is usually the assignment of parameters in the Part Control Assign Page.

In the second step, a part of the assigned parameters can then be routed to the Super Knob. This is done in the display "Common > Control Assign", where the Common Assignable Knobs (Source) are assigned to the desired Part Assignable Knobs (Destination).

But before you are venturing into a Super Knob programming, you should first look at the appropriate settings of Preset Performances. Here is an example with a relatively simple Super Knob programming.

EXAMPLE: PRESET PERFORMANCE
„PERCUSSIVE DANCE 1“ (CATEGORY
„SYNCOMP“)

This is a Single Part Performance with a simple, easily understandable function of the Super Knob.

- Press successively [EDIT] and [COMMON]
- Select "Control" > "Control Assign"
- At the top left of the display activate "Autoselect"
- Turn on ASSIGN (the button left of the Super Knob), so that the Assignable Knobs are active
- Move the Knobs 1-8 one after the other. The Display Filter switches automatically to the corresponding page. You can determine for each Common Assignable Knob, whether and which Part Assignable Knobs are assigned

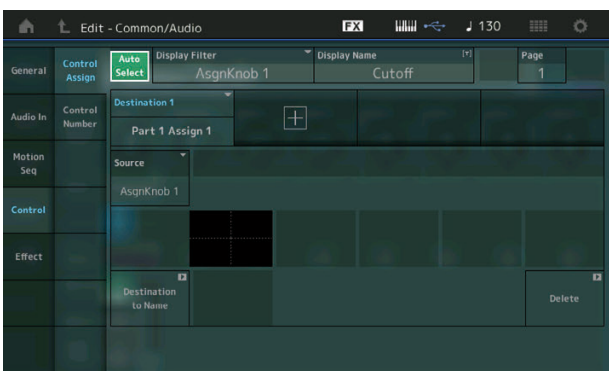

You will notice the following assignments:

- Source = Common Assignable Knob 1
- Destination = Part 1 Assignable Knob 1
- Source = Common Assignable Knob 2
- Destination = Part 1 Assignable Knob 2
- Source = Common Assignable Knob 3
- Destination = Part 1 Assignable Knob 3

The first three Assignable Knobs of Part 1 are thus routed to the Super Knob.

- Stay in EDIT mode and select Part 1
- Determine which parameters are assigned to the Part Assignable Knobs by observing the "Mod / Control > Control Assign" values in the Common Part
- To do so, move the Knobs, to which you have determined a Super Knob allocation in the previous step



You will notice the following assignments:

- Assignable Knob 1 = Cutoff
- Assignable Knob 2 = Filter Resonance
- Assignable Knob 3 = Volume

These visible destination parameters for each assigned Knob are the parameters that are controlled by the Super Knob.

The Super Knob starts with the value 0, ie the far left. With increasing movement to the right the "Cutoff" is decreased and "Resonance" slightly increased. To avoid distortions when the Filter is closed and the Resonance on a high value, the Part volume is slightly lowered.

MOTION SEQUENCE

With the Motion Sequencer complex sound controls can be carried out on the basis of parameter assignments in the Control Assign displays.

The Motion Sequencer works similarly to a conventional multi-track step sequencer, but with the difference that here no notes, but in the Control Assign assigned sound parameters can be controlled in real time. The Motion Sequencer can be used independently of or in addition to the Arpeggiator and synchronised with all Tempo-dependent processes in MONTAGE.

The Motion Sequence function is present in each Performance Part. The Common Part and the Parts 1-8 all have up to four Lanes available. However, a maximum of eight Lanes can be used within a Performance.

A Lane can be virtually regarded as a Track of the Motion Sequencer, which controls the parameters that were assigned to it in Control Assign. Each Lane has its own set of parameters. Each of the four Lanes available in a Part contains eight Sequences. So, in one Part a total of 32 individual Sequences can be included.

In PLAY mode, the display "Motion Control > Motion Seq" conveys an overview of the Lanes used in a Performance. For each Part there is a global Motion Sequence Part Switch ("PartSw"), which is set to ON for all Parts per default. The respective Lanes 1-4 are activated to the right of the PartSw. For example, if the Lanes 1-3 of a Part are set to ON, at the top of the display "Active 3/8" appears. Therefore there are three of eight available Lanes active.

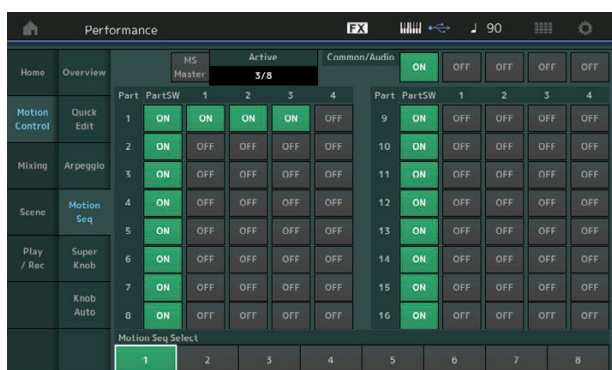

If eight Lanes are already active, one of these Lane must be turned OFF before another can be activated.

The Motion Sequence parameters of the Parts are available in EDIT mode from the display "Motion Seq" with the two sub-pages "Common" and "Lane".

The display "Common" shows the Knob parameters which are related to the areas Arpeggio and Motion Sequence. These are used for changing global parameters in real time and play no role in the programming of Motion Sequences.



The display "Lane" shows in a matrix the settings for the Motion Sequence functions of each Part.



The Lanes can be switched on and off using "LaneSW". These switches are identical to the Lane Switches in the Overview Page in PLAY mode as described above.

"MS FX" determines whether the global parameters Amplitude, Shape, Smooth, and Random are active or not to be controlled with the Motion Seq Knobs.

"Trigger" can be activated for each Lane when the Motion Sequence is to be started by pressing the [MOTION SEQ TRIGGER].

"Sequence Select" selects the Motion Sequence Numbers 1 -8. When switching the Sequence all Lanes are switched simultaneously. If you are not in EDIT mode, you can switch the Sequences with the MOTION SEQ SELECT buttons 1-8.

To edit the selected Sequence of a Lane simply press "Edit Sequence" at the bottom of the Lane Page.

There, the Sequence can be programmed similar to a conventional step sequencer.

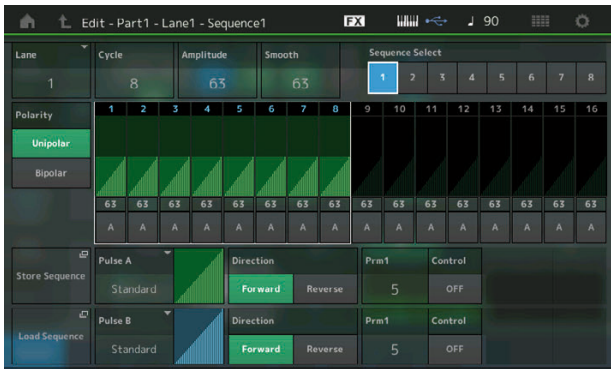

The number of Steps can be set with the parameter "Cycle". The default setting "Cycle = 8" offers eight Steps.

For each Sequence with "Pulse A" and "Pulse B" two different curves can be selected. These can be played back either forward or backwards (reverse) and - depending on the selected curve - be modified by one (Prm1) or two parameters (Prm1 + Prm2).

ARPEGGIATOR

The Arpeggio functions of MONTAGE have been largely taken over from the MOTIF XF. However, there are the following enhancements:

On the MOTIF XF there were five ARP SELECT numbers for each Voice or Part, which were selected by the five sub-function buttons (SF1-5). On MONTAGE there are at eight ARP SELECT numbers selectable with the [ARP SELECT] buttons in the bottom row of the button matrix. In addition, the ARP SELECT numbers can also be assigned to the Scenes 1 - 8.

The number of Arpeggio Types has been increased from 7,881 (MOTIF XF) to 10,000 (MONTAGE).

There is a new group of special Arpeggio Type for musical styles like Dance / Electronic, which are marked with the suffix "2Trk". These 2-Track Arpeggios contain a switch, which is dependent on the number of keys you play.

If you press one keyboard key, only Track 1 of the Arpeggio is played. This includes an authentic Dance / Electronic phrase, for example, a typical step sequence, or sequences that may include chord changes.

However, if you press more than one keyboard key, a conventional Arpeggio is played, which is also suitable for playing chords.



SCENES

With the Scenes 1-8 certain settings of the Parts can be stored like a snapshot in digital mixers.

The illumination of the Scene buttons indicate whether a Performance uses Scenes or not. Dimly lit buttons indicate that Scenes can be selected. The current Scene is characterised by a fully lit button.

In the Preset Performances the Scenes are mainly used for a common switching of MOTION SEQ SELECT and ARP SELECT. With these, a Performance can be arranged similar to a music production.

With these steps you will quickly understand how the Scenes work:

- Select a Performance which uses Scenes - you can see from the illumination of the Scene buttons
- In the Performance Play Mode select the display "Scene"
- Play the Performance and try the Scenes 1-8 to get to know the arrangement that is realised with these Scenes

Each time you switch to another Scene you can see on the display that the Motion Seq Select and the Arp Select numbers change.

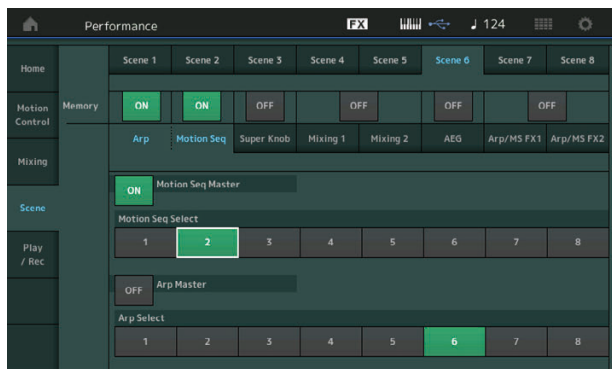

In the Scene display you can set the Arp Select numbers 1-8, but not the Arp Types themselves. In order to determine which Arp Types are assigned to the respective Arp Select numbers in a Part, you have to select the desired Part in EDIT Mode and call up the display "Arpeggio > Individual".

In the graphic below, all parameters which can be saved in a Scene are summarised.

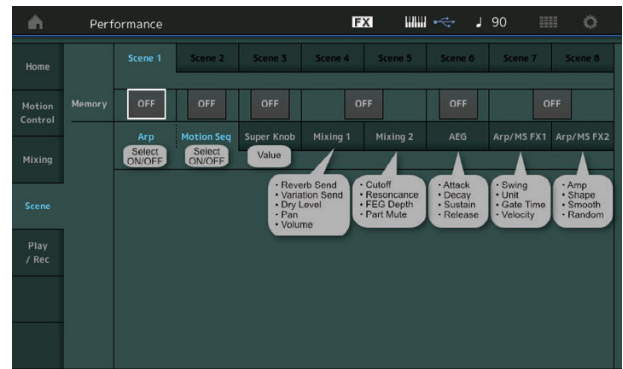

ENVELOPE FOLLOWER

An interesting feature that can also be settled in the broader sense in the field of Motion Control, is the Envelope Follower. With this function parameters of a Part can be modulated by the output of another Part. In this way, movements or rhythmic sequences of a Part can be transferred to other Parts.

The setting of the Envelope Follower takes place by selecting the appropriate parameter assignment in the Part display "Mod / Control > Control Assign".

For this purpose there are EnvFollow 1-18 available as a Source.

The numbers 1-16 correspond to the Parts 1-16, the numbers 17 and 18 mean the A/D Parts L + R.

SIDE CHAIN MODULATION

The Side Chain Compression effect has long been extremely popular in music styles like Dance / Electronic - in MONTAGE this effect is easy to implement using the compressor effects with their Side Chain Modulation parameters.

In Side Chain Compression (also called "ducking" or "pumping") the signal of a track is turned down in volume when the level of other tracks - ie the modulating signal - rises. For example, a bass drum signal is often fed to the Side Chain Input of a compressor.

The following insert effects of MONTAGE feature a Side Chain Input:

- *VCM Compressor 376*
- *Classic Compressor*
- *Multiband Comp*
- *Ringmodulator*
- *Dynamic Ringmodulator*
- *Dynamic Filter*
- *Dynamic Phaser*
- *Dynamic Flanger*

The Side Chain modulation is activated for a Part by selecting the Part that is to be used as a modulation source in the "Side Chain" parameter in the Insert Effect Page. This will be mostly the Drum Part.

A typical application of Side Chain modulation is the rhythmic level reduction of a trance synth pad by a bass drum that is played exclusively on the four beats ("four on the floor"). The resulting sound is often referred to as "pumping pad".



FM-X

THE RETURN OF FM

The expanded FM synthesis used in MONTAGE is referred to as "FM-X".

FM-X PART FEATURES

What distinguishes an FM-X Part in MONTAGE from the classic FM tone generation in the DX7?

The main enhancements over the DX7 are:

- 8 Operators (DX7 = 6 Operators)
- 88 Algorithms (DX7 = 32 Algorithms)
- 7 Spectral Forms (DX7 = only sine)
- Spectral Skirt (Broadening the Harmonic Curve)
- Spectral Resonance (Shifting the Harmonic Peaks)
- Frequency Envelope Generator
- Comprehensive Controllers
- Random-controlled Panorama
- Filter with multiple types
- Additional Common LFO
- 3-Band and 2-Band EQ
- Multiple FM Parts can be used in a Performance
- Insert and System Effects
- Motion Sequences
- Intuitive sound editing with sliders, buttons, and knobs
- Sound control using the Super Knob
- Sound can be modulated by other Parts or external audio signals using the Envelope Follower
- Combination with AWM Parts and Drum Parts
- Arpeggiator with 10,000 Arpeggio Types
- FM stereo sounds possible when using two or more Parts

THE MONTAGE WAY OF DOING FM SYNTHESIS

With MONTAGE Frequency Modulation becomes a completely new experience. Due to the touch screen and the intelligent arrangement of parameters any dive in deep menu levels is omitted.

For example, you can easily make a choice from the 88 Algorithms by using a clear matrix. If you select "Part Settings > Algorithm > Search Algorithm" from the Part Edit display (Common), you get the opportunity to narrow down the search for the number of Carriers and Modulators. The horizontal selection "Carrier" determines the number of Carrier Operators while "Chain" (vertical) indicates the index for the Modulators. A discreet background-image contributes significantly to this clarity by indicating how many Algorithms correspond to the selection made.

The presentation and editing of Envelope parameters for example is solved appealing and comfortable. Value

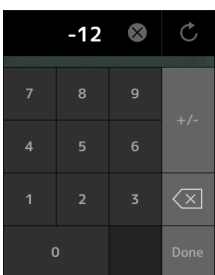

changes are possible by selecting the appropriate field and using the buttons and the Data Wheel, moreover, another tap on the field opens a numerical entry window.

Parameters such as Spectral Form and Spectral Skirt bring "analog feel" into the world of Sine-based FM tone generation. A wide selection of Filter Types, LFOs and EQs for each FM X Element also help to shape the sound according to your wishes.

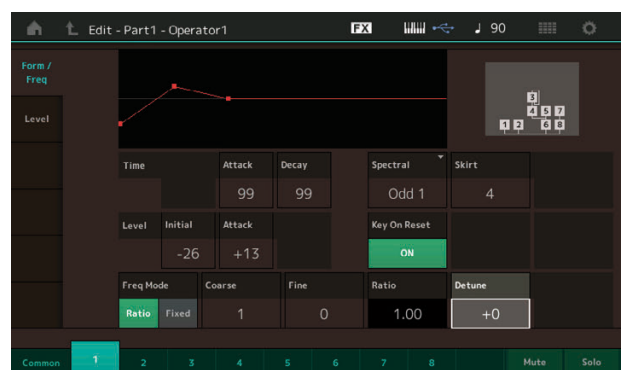
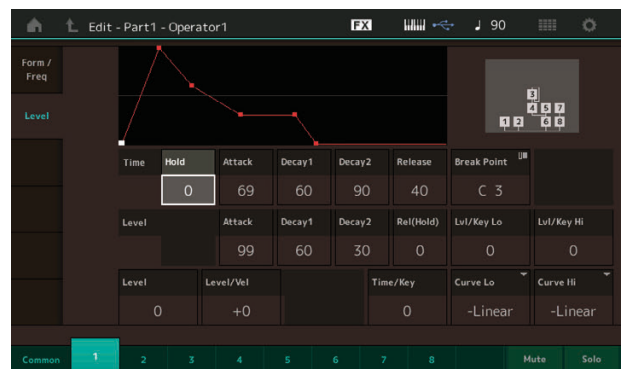
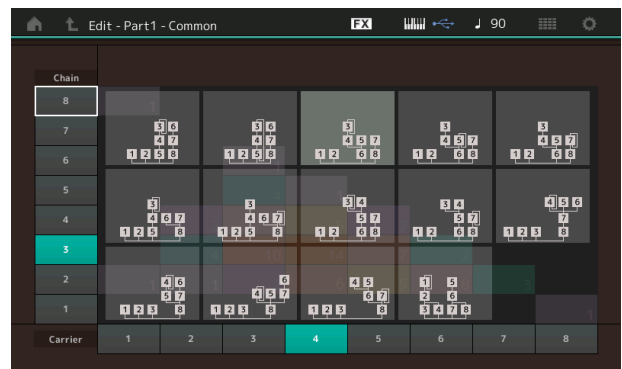
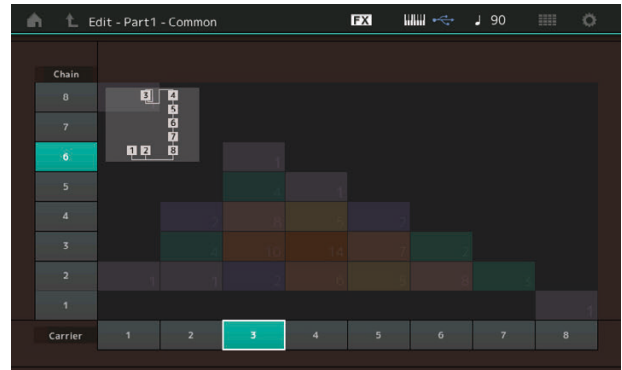



WHAT IS FM?

The FM synthesis was already developed in 1967 by the American scientist Prof. Dr. John Chowning of Stanford University, but not published until 1973. A year later the Yamaha Corporation bought the patents to the then revolutionary synthesis method. In 1983 the Yamaha DX7 was introduced and put the synthesizer world upside down - pushing even synth legends like Moog or Oberheim to the background.

Countless music productions were decisively influenced by the sound of the DX7, whose strengths lay mainly in completely new electric pianos, synth basses, harps, organs, and metallic synth sounds. The dynamics of these sounds were the benchmark for all future digital sounds.

FM is short for "Frequency Modulation". Here Oscillators are modulated by other Oscillators whose Volume and Frequency critically characterise the sound. In the Yamaha terminology the Oscillators of FM synthesis are called Operators. The simplest interconnection is that one Operator as Carrier is modulated by another Operator as the Modulator. But, since the FM tone generator of MONTAGE, however, features a total of eight Operators for a sound, the Algorithms (that determine how the Operators are linked) are often much more complex.

When editing Voices the Volume and Frequency of the Operators play an important role. The Volume of the Modulator determines the modulation intensity. The higher it is, the more harmonics are added to the Carrier's signal. With increasing count of harmonics the sound gets brighter. The basic sound of the Carrier Operator - a pure sine wave - is transformed by simple modulations to a sine wave that's enriched with harmonics.

Using further modulations and corresponding Frequency settings then create square waves, sawtooth waves or complex sound spectra which can not be produced with conventional analog synthesizers. In addition, the sound is characterised by multi-stage Envelope Generators that are present for each Operator.

After the ground breaking success of the DX7 the FM synthesis has been implemented in a large number of Yamaha synthesizers.

Some popular examples are: TX7, TX816, DX21, TX81Z, DX27, DX100, FB01, DX7II, TX802, V50, SY77, SY99, FS1R, DX200, PLG150-DX, reface DX.



FILE AND LIBRARY MANAGEMENT

Storing and managing large amounts of sounds for MONTAGE is extremely simple thanks to the support of USB drives as storage media.

STORING USER FILES

The entire user data can be saved as User files with the extension ".X7U" on a USB memory stick. A User file includes the following data:

<i>Performance</i>	<i>max. 640</i>
<i>Curve</i>	<i>max. 32 (for Control Assign + Motion Sequence)</i>
<i>Arpeggio</i>	<i>max. 256</i>
<i>Motion Sequence</i>	<i>max. 256</i>
<i>User-Waveform</i>	<i>max. 2,048</i>
<i>Micro Tuning</i>	<i>max. 8</i>
<i>Live Set</i>	<i>max. 2,048</i>

In addition to the Preset and User Banks there are eight Library Banks available, which can be loaded as Library files (extension ".X7L"). The difference to the User Bank is merely that the Performances of the Library Banks can not be edited.

LIBRARY FILES

A Library file is a copy of a complete User Bank.

The Library file is created by string a User Bank - ie all User Performances, User Waveforms, Samples, and User Arpeggio Patterns - as a Library file. Subsequently, the Library file can be loaded into the instrument, whose Performances can then be used like user-created Presets. The first Library file is automatically loaded into the Library Bank 1, the next in the Library Bank 2 etc.

The full contents of User Memory (incl. User Waveforms and Samples) can be saved as a Library with these steps:

- Press [UTILITY]
- Select the display "Contents" > "Store / Save"
- Select the Content Type "Library" at the top of the display
- Tap on "[Save As New File]"
- Enter a name and confirm with "Done"

Right afterwards the saved Library file can be loaded with these steps into a Library Bank:

- Press [UTILITY]
- Select the display "Contents" > "Load"
- Select the Content Type "Library" at the top of the display
- Select the previously saved Library file (extension ".X7L")

IMPORTANT NOTE:

If you are editing a Performance from a Library Bank, it can only be stored as a new User Performance. It is not possible to directly store it in the Library Bank. For this reason, in addition to the Library file you should always store the same memory contents of the User Bank as a User file. If it is later necessary to change Performances of a Library or to add Performances to it, this has to be done in the User Bank the Library was made from. Subsequently, the modified User Bank must be saved as a Library file and the changed Library to be reloaded again.



SEQUENCING

The sequencer functions of MONTAGE are enormously helpful to record the inspiration you just have with the instrument - with a simple push on a button. Or prepare backing tracks which you can then embed in your live performance.

SONG RECORDING (DIRECT PERFORMANCE RECORDING)

The Song features are accessible by selecting the Play / Rec function (from the Performance Main Page). The button [RECORD] in the Sequencer Transport block is always active and immediately switches to a MIDI Record Mode. The display offers a few settings such as Tempo, Time Signature, Position selection and Quantisation. By default the Tempo is taken from the active Performance and all Parts are set in the Play Mode. The Playback button starts the recording. This functionality is known from the MOTIF series as "Direct Performance Recording", to quickly and easily realise recordings of your performance. All operations of controllers such as Super Knob, Knobs and Faders, Scene parameters, Assign and Motion Sequence buttons are recorded. A resulting recording is

automatically saved as "New Song *", the number * varies depending on the number of already saved recordings.

Every important recording should be saved as a MIDI file (format 0). This is directly possible from the Record display. It requires a connected USB storage device. If the MIDI file is to be processed further in a DAW, you should extract the parts by their MIDI channels after having imported the file onto a MIDI Track of your DAW. If the Performance is active in MONTAGE you should be able to playback the file instantly. Only the "Arp Play Only" parameter must be disabled for the corresponding Parts.

SONG PLAY INCLUDING STANDARD MIDI FILES

MONTAGE can load and play back Songs and Standard MIDI files from a USB storage device. The following steps are required:

- *Enable the Performance Mode*
- *Optional: Select an INIT Performance*
- *Select Play / Rec on the display*
- *Select "MIDI"*

- Tap on "Song Name" and then "Load"
- Tap on "Content Type" and then ".mid File"
- Locate the MIDI file on your USB device and select it

With this procedure, the MIDI file is loaded into the current Performance and the RAM memory. This way up to 64 files can be loaded that are kept in memory and are available even after the instrument was shut down. The selection is made via the Content Type "Song&Perf". General MIDI files are played correctly.

PLAYBACK OF AUDIO FILES FROM A USB DEVICE

Audio files can be directly played back from a connected USB storage device, the file has to be in .WAV format. The following procedure is required:

- Enable the Performance Mode
- Select "Play / Rec" on the display
- Select "Audio"
- Tap on "Audio Name" and then "Load"
- Locate the audio file to your USB device and select it
- Start the playback

After a tap on the fields of Position and Volume these can be changed with the dial. During playback, the screen and several buttons are locked. The selected Performance is, however, active, as are the Scene buttons, Super Knob, and Controllers.

SO FAR SO GOOD...

So much then for our basic introduction of MONTAGE. You can be sure that in the coming issues we will discuss individual areas of the new flagship in Yamaha's fleet in great detail.

Hans-Peter Henkel & Peter Krischker

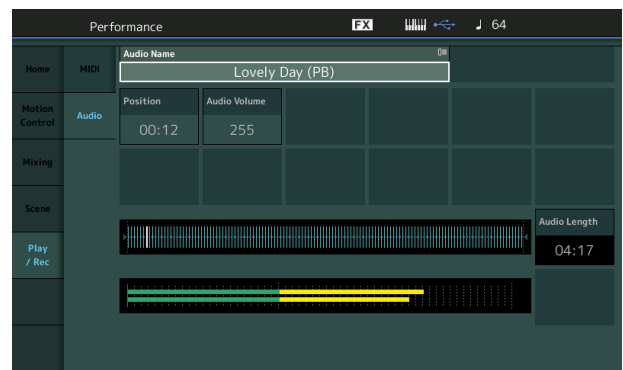

IMAGES



DTX

502SERIES

▶ SOUND

100 KITS, BIG WAVEFORM
- MORE DETAILED SOUNDS

▶ FEEL

REALISTIC AND QUIET

▶ POWER

INTERNAL TRAINING FUNCTIONS
+ FREE APPS

NEW DTX502 SERIES ELECTRONIC DRUM KITS
- THE NEW LEVEL OF SILENT ELECTRONIC DRUMMING



ADD INDIVIDUAL TOM-, CYMBAL- OR MULTIPADS
TO CONFIGURE **YOUR PERFECT KIT!**

NEW!
DTX502
MODULE





FREE KITS FOR THE YAMAHA DTX700

How about some new Drum Kits for your Yamaha DTX700? Available for free download? Well, here you are!

Of course you can also modify these Drum Kits as you like. All Kits were created using the internal sounds. In the DTX700 you have many options to change the sounds. A large array of functions is available: Effects, Pitch, Attack, Decay, Release, Muffling, or Sustain, just to name a few.

Important! Please store your settings on a USB flash drive before loading the Drum Kits into your DTX700. Press: MENU - FILE - SAVE - ALL - enter a name - EXECUTE - CONFIRM. With the new iOS app 700Touch you can also store your Kits in your Dropbox.



HINT: The iOS App 700Touch makes editing you DTX700 a breeze

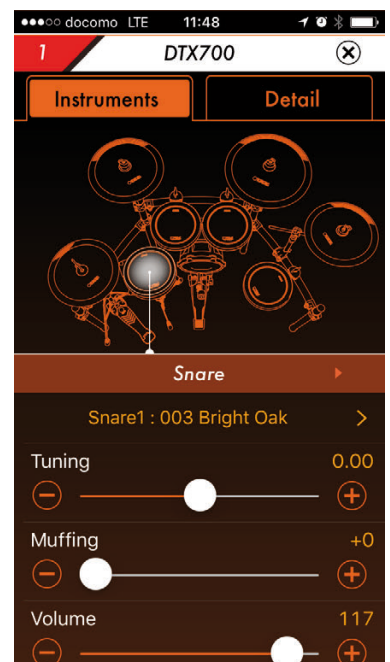

You can request the Drum Kits by sending an e-mail with the subject "DTX700 RM Kits 2016" to the following address:

DTXnews@easysounds.de

Once you have downloaded the file "DTX700_RM_2016.zip", unzip the zip file and copy the complete Yamaha folder to your USB drive. Important: The DTX700 necessarily needs the folder structure that is included in the file.

Now load the Drum Kits into your DTX700. After connecting the USB flash drive to the DTX700 module press: MENU - FILE - LOAD - ALL - "DTX700RM.T7A" - EXECUTE - CONFIRM

If you use the same USB flash drive on which you have already stored your own Drum Kits, the necessary folder structure is already created there. In this case, simply copy the file "700_RM16.T7A" from the downloaded zip file to the "ALL" folder on your stick. Please do not overwrite your existing folders.

THE FOLLOWING DRUM KITS ARE LOADED INTO YOUR DTX700:

- *Kit 51. SOLID ROCK*
- *Kit 52. FUNKY FUSION*
- *Kit 53. CRISPY CRANK*
- *Kit 54. JAZZ IT UP*
- *Kit 55. SOLID STUDIO*

You can also load the Drum Kits individually into your module. To do so press: MENU - FILE - LOAD - set to KIT - "700_RM16" - select the desired Kit - select target Kit - EXECUTE - CONFIRM

I hope that you like the Drum Kits provided here. Have fun!

Your Ralf Mersch





YAMAHA DTX MULTI-12 & M12 TOUCH APP

DIRECTLY TRIGGER SAMPLES, LOOPS, AND PLAYBACKS FROM YOUR IPAD!

In this workshop I would like to show you how you can use your iPad as an additional sample memory. Whether you own an iPad with 16 or 64 gigabytes of storage, in any case, it extends the possibilities tremendously.

The length of own samples and loops is limited in the Multi 12. A single mono sample can be up to 2 MB in size, a stereo sample a maximum of 4 MB. Overall, in the Multi 12 64 MB of sample memory is available. But by using the new iOS app M12Touch you have an extension at hand. Because the app allows you to trigger complete songs, samples, or loops from the memory of the iPad.

THE PREPARATION

Please save your own settings on a USB flash drive before programming new Drum Kits.

Then you should transfer your music, sounds, or loops to your iPad. There are several ways to bring your own samples to the app: iTunes File Sharing, iCloud Drive, Music Library, or Dropbox.

THE CONNECTION

My iPad is connected to my Multi 12 by a Yamaha i-UX1.

But you can also use an Apple Camera Connection Kit

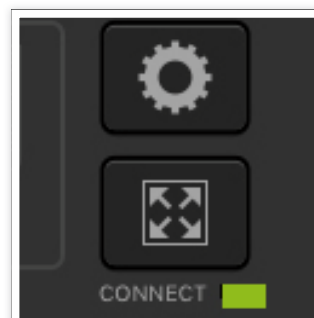

and a standard USB cable. Once connected, launch the app. A small green indicator at the bottom right indicates whether the connection is correct.

THE PROGRAMMING PROCESS



If you have already programmed a few things, you can transfer the data from your Multi 12 to the iPad. For this, press the Transfer button.

Now your iPad mirrors the current memory contents of your Multi 12 and lets you work with the existing Drum Kits. In the following I want to assign a percussion loop to a single Pad. To do so I first hit the desired Pad, which will open a new window in the app.

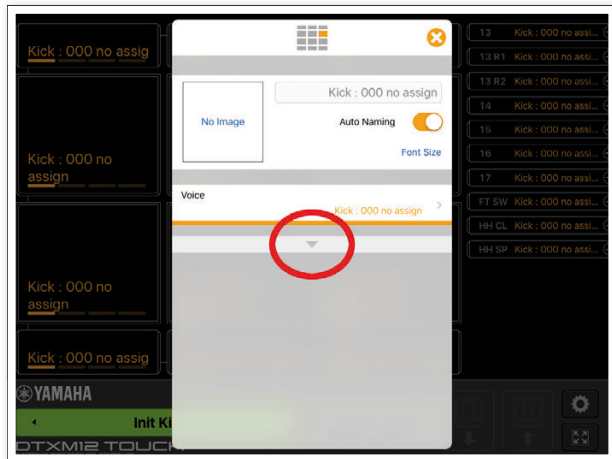

There I tap on the little arrow below the orange-colored line. I choose "App Audio File Play", the app then jumps to a new menu.

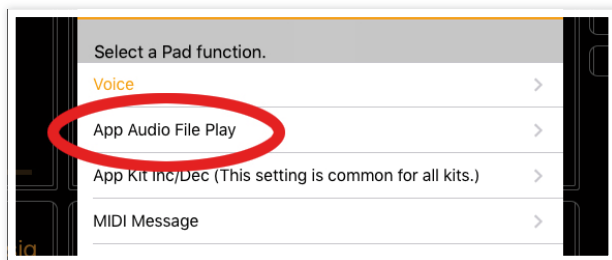

From this menu you can select where the sounds and loops are stored. You can also select a song from the Music Library. You can also select how the Pad should behave when it is played: The modes "Loop", "Hold", and "Restart" are available and are each explained below. I have stored my loop in the iTunes File Sharing folder and choose it from there.

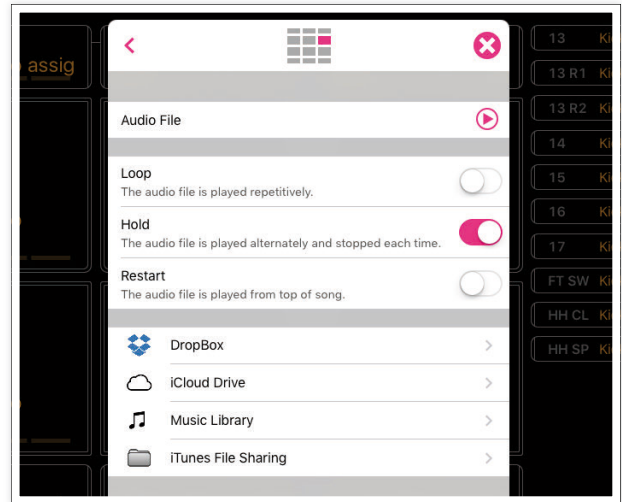

Important: In this case the sound will come from the iPad. So you should connect headphones or connect the iPad to a mixing desk. Or connect your iPad to the AUX IN audio input of the Multi 12, only a single cable is required to do so (mini stereo jack to 1/4" stereo jack). Next to the AUX IN jack on the back the corresponding Gain knob can be found to control the volume input.

Now I can hit the selected Pad on the Multi 12 and without delay the app plays my loop.



To be on the safe side you should transfer all the data back to your Multi 12 at the end of your programming session.

CONCLUSION

The Audio File Play feature is really great! My iPad Mini has about 8GB of free memory, which is now available for my own loops and sounds - that is almost 780 minutes of uncompressed audio. Excellent!

Have fun trying the feature for yourself.

Your Ralf Mersch



On the last page of the Music Production Guide a link can be found to download a zip-file containing all previous editions (in the Box „Music Production Guide History“).

In addition, we offer the opportunity to access all previous issues online. The Music Production Guide Archive is available from everywhere you've got connection to the internet.

A simple click on the issue is all you have to do to open and download it as a PDF.

The link to the English editions:

http://www.easysounds.eu/mpghistory/history_en.htm

The link to the German editions:

<http://www.easysounds.eu/mpghistory/index.html>



Music Production Guide History

(also known as MOTIF News Guide until 08/2010)

Notes on the use of this document

The number for each issue is supplied with a link that opens the corresponding PDF file in the browser.

Use the following link to download all previous issues in a compressed ZIP file from the EASY SOUNDS website:
http://www.easysounds.eu/NewsGuides_E.zip

Jump to year: [2009](#) | [2010](#) | [2011](#) | [2012](#) | [2013](#) | [2014](#) | [2015](#)

2009

12/09 [download](#)

- Page 2 - 3: Rebirth of a legend: CP1 Stage Piano
- Page 4 - 5: Brand new: Tenori-On "Orange"
- Page 6: MOTIF XS Christmas Special "Oriental Instruments"
- Page 7: Cubase Basic: Workshop
- Page 8: hape13's column
- Page 9 - 11: MOTIF Know How: Frequently asked questions – and their answers!
- Page 12 - 21: MOTIF® Sys-EX – the easy way! (Vol. 1 + 2)



2010

01/10 [download](#)

- Page 2: Yamaha's new Stage Piano flagship CP1
- Page 4: New Yamaha product videos online
- Page 5: S90 XS / S70 XS piano workshop
- Page 11: MOTIF XS Workshop: Creating sound libraries with



YAMAHA GOODIES FOR MX49/MX61: LIVE INSTRUMENTS PERFORMANCE KIT

Yamaha offers free additional, yet high-quality content for MX49/MX61 users. It was produced by Yamaha Music Europe in cooperation with EASY SOUNDS.

LIVE INSTRUMENTS

„Live Instruments“ includes a high-quality collection of sounds of the categories piano, electric piano, clavinet, organ, mellotron, strings, brass section, and synth. So it's a selection of instruments that all keyboardists in bands require regularly.

- 100 Voices
- 32 Performances, divided into:
 - SPLIT Performances (Instruments & ARP)
 - LIVE Performances (Split & Layer)
 - LIVE Performances (Single)
 - LIVE HYBRID Performances

The free soundset "Live Instruments for MX" can be ordered by writing an e-mail with the subject "Live4MX" to:

live4mx@easysounds.de

Immediately after registration you will receive an email from EASY SOUNDS containing the download link for the activation of the content.

PERFORMANCE KIT

The "Performance Kit" consists of the following components:

- MX49/MX61 Performance Library
- WAV pool with about 200 WAV files totaling 93 MB (drum loops, vocal and vocoder phrases, sound effects, and atmospheres)
- MIDI loops & arpeggios

To register for this free goodie simply write an e-mail with the keyword „MX49/MX61 Performance Kit“ to:

mxgoodies@easysounds.de

As soon as the registration process is complete you will receive an e-mail from EASY SOUNDS with a password and a link where the file can be downloaded.

MOX „SOUND & GROOVE KIT“



The free MOX „Sound & Groove Kit“ is available for all registered users of the MOX.

This soundset includes an „Electronic & Dance“ soundlibrary featuring 128 Voices - a selection of the best synth-sounds from the EASY SOUNDS soundlibraries for the MOTIF series.

In addition, the package includes a WAV loop pool with drums, synths, vocals, sound effects, and atmospheres for Cubase AI and other DAWs.

Registration for this goodie is done by writing an informal e-mail with the keyword „MOX“ to this e-mail address:

moxgoodies@easysounds.de

EASY SOUNDS SOUNDSETS FOR MOX

The popular MOTIF soundlibrary from EASY SOUNDS is also available in MOX format.

The following products are available:

- Yamaha MOX „Live Instruments“
- Yamaha MOX „Nature of Chill“
- Yamaha MOX „Dance Pro“
- Yamaha MOX „Phat Analog II“
- Yamaha MOX „Xtasy“
- Yamaha MOX „Synth Xtreme“
- Yamaha MOX „Magical Pads“
- Yamaha MOX „Stage & Studio“
- Yamaha MOX „Phat Analog“
- Yamaha MOX „Organ Session“
- Yamaha MOX „Hypnotic Stepz“
- Yamaha MOX „Chill Xperience“
- Yamaha MOX „Mystic Spheres“
- Yamaha MOX „Dance Xpanded“

Visit the EASY SOUNDS online shop:

www.easysounds.de

YAMAHA CP1 ARTIST PERFORMANCES

A free soundsset in excellent quality is available for every CP1 user.

A total of 64 Performances were programmed by renowned sound designers Johannes Waehnelde and Peter Jung on behalf of Yamaha Music Europe.

The soundsset can be requested by sending an e-mail to

cp1goodies@easysounds.de

containing the keyword „CP1 Artist“.

You will receive an e-mail from EASY SOUNDS containing a link where the file can be downloaded.



MOTIF XF FLASH MEMORY CONTENT



Yamaha is working with third party software vendors to offer an extensive amount of free and optional Flash Memory content for registered MOTIF XF users.

The flash memory content package „Inspiration In A Flash“ make a perfect first stock for a sample-library of up to 2 GB for the non-volatile Flash Memory of the MOTIF XF. This content package contains three new User Voice Banks, 353 User Waveforms, 458 MB of Samples and 12 User Drum Kits. It focusses on the sound categories piano, organ, brass & reeds, pads, synths, oriental instruments and drums.

These Voice Banks can be individually loaded into the volatile SDRAM of the MOTIF XF, if no Flash Memory Module is installed.

The „Symphonic Orchestra Library“ features 128 User Voices, 34 User Waveforms and 336 MB Samples (979 Keybanks).

The orchestra library produced by Prof. Dr. Peter Jung (Duisburg-Essen, Germany) is based on recordings that were created over the past five years with the participation of two well-known Central European symphony orchestras.

The recorded sounds are very lively and authentic. Some feature delicate impressions of „disturbances“ that are typical for strings, such as the sound of slightly hitting the instrument body with the bow. All recordings were digitally processed on PCs, collaborating with well-known sound designers.

In addition to the orchestra sounds the Voice bank also contains sounds of categories like Electric Organ, Pipe Organ, Acoustic Piano, and Electric Piano.

To be able to load the complete All-file a Flash Expansion Memory Module (512 MB or 1 GB) is required. Single Voices can also be loaded into the SDRAM memory of the MOTIF XF (volatile sample memory).

This free content for the MOTIF XF can be requested by sending an e-mail containing the keywords „MOTIF XF Inspiration & Symphonic“ to:

xfgoodies@easysounds.de

The MOTIF XF user will receive an e-mail from EASY SOUNDS with a password and a link where the file can be downloaded.

SOUNDSET FOR MOTIF XF UND MOXF VP1 PHYSICAL MODELING

Yamaha offers another free soundset for the MOTIF / MOXF that is dealing with a truly legendary Yamaha synthesizer: the Virtual Acoustic Synthesizers VP1.

The VP1 sounds brutal. The sound impresses by an amazing vitality, coupled with amazing stereo renderings. There is no doubt that even after almost twenty years the VP1 can sonically compete with current workstations. It was and is a truly remarkable result of exquisite engineering.

sound, by varying the parameter values, can be dynamically changed using the numerous performance functions of VP1.

The author Prof. Dr. Peter Juung has carefully recorded sounds of the VP1 and created a sound set. The VP1 soundset includes 565MB of sample data. Everything was recorded in stereo and organised in 19 Waveforms, which rely on 536 Keybanks. From these Waveforms 48 Voices whose character was previously only found in the original were programmed exclusively for the MOTIF and MOXF.

DER VP1 FROM THE INSIDE

The VP1 uses "Physical Modeling". With the help of a physical model, e.g. of a stringed instrument, you can get an actual sound by setting the parameter values. The excitement, e.g. a pick or a bow brings virtual kinetic energy into the model, which is made to audible sound by the model.

A sound generated with the "Physical Modeling" synthesis is not a simple snapshot that does not change like with pure sampling. Rather than that, the "physical modeling"

The soundset takes us into the magical world of "Physical Modeling" synthesis of the VP1.

The soundset "VP1 MOTIF" can be requested by writing an e-mail with the subject "VP1" to:

vp1@easysounds.de

After successful registration you will get an e-mail from EASY SOUNDS containing the download link for the activation of the content.

10TH ANNIVERSARY PACK

MOTIF XF

Ready to use
on every stage
and in every studio

Extra bonus inside

64 Voices



In special cases some birthdays are celebrated quite more than a single day - which is also true for the tenth anniversary of the Yamaha MOTIF. Wojtek Olszak pulls that event back into memory with his 10th Anniversary Pack.

This 10th Anniversary Pack uses samples from previously published promotional soundsets, namely:

- Chicks Mark V
- Peter Jung's CS-80
- CF - CP1

The 64 Voices of this pack are roughly divided into the following categories:

- Acoustic Pianos
- E-Pianos / Clavinets
- CS-80 Leads

- CS-80 Brasses
- Pads
- Strings
- Organs
- Miscellaneous

The free soundset "10th Anniversary Pack for MOTIF XF by Wojtek Olszak" can be ordered by writing an e-mail with the subject "10th Anniversary Pack" to:

10th_anni_wo@easysounds.de

Immediately after registration you will receive an e-mail from EASY SOUNDS containing the download link for the activation of the content.



MOTIF XF / MOXF PERFORMANCE SOUND- SET „HYBRID PERFORMER“

The recent Goodies contained almost exclusively User Voices and Samples. For some time now many users, however, expressed to get new content in the field of Performances and Live Mixings. Yamaha Europe now corresponds to this wish and provides new sound sets: Hybrid Live Performances for MOTIF XF and MOXF.

The following Performance Sets are included in the download:

HYBRID PERFORMER - SET 1

32 Performances

Performance mode

Programmed by HaPe Henkel and Peter Krischker

HYBRID PERFORMER - SET 2

16 Hybrid Live Performances

Song Mixing mode

Programmed by HaPe Henkel

HYBRID PERFORMER - SET 3

32 Hybrid Live Performances

Song Mixing mode

These Performances are based on chart titles using the User Sound Library that has been launched some years ago

Programmed by Jean Moric Behrends

As you can see above, the first set contains "traditional" Performances.

The sets 2 and 3 on the other hand contain "Hybrid Live Performances", which are very popular among live keyboardists.

Hybrid Live Performances are Mixings at the highest level and with the broadest capabilities. They contain not only complex layer or split programmings, but even allow to switch between sounds without interruption. Many ambitious and professional keyboardist prefer these special Live Performances over traditional Performances with their four different Parts.

A Hybrid Live Performance is created in the Song or Pattern Mixing mode. In contrast to the Performance mode, up to 16 Parts are available here. In a Hybrid Live Performance groups can be formed with different MIDI Receive Channels (Receive Ch.). Thus, within a single Mixing even more than one Performance can be realised. They can be selected by using the TRACK SELECT buttons without having the previous sound cut off.

A common download folder is set up for the three sets of the Hybrid Performer series.

The sets are available for MOTIF XF and MOXF and can be requested by writing an e-mail with the subject "Hybrid" to:

hybridperformer@easysounds.de

After registration you will receive an e-mail containing a download link from EASY SOUNDS with a clearance for the content.

MOTIF XS: EUROPEAN LOYALTY PROGRAM AND ORIENTAL SOUNDSET

The „European Loyalty Program“ offers MOTIF XS users free additional but nonetheless high-class content.

It is mainly a premium Voice and Sample library produced by EASY SOUNDS in collaboration with Yamaha Music Europe which contains the following:

- *The 3-layers Yamaha S700 stereo piano (32 MB compressed)*
- *„Sweet Voices“ and choir and scatvoices from the Yamaha Tyros*
- *Best-of compilations of the optional soundsets from EASY SOUNDS*
- *A WAV pool containing 200 WAV files with 93 MB in total*

The MOTIF XS soundset „Oriental Instruments & Percussion“ was produced by turkish musicians and contains the following:

- *36 Performances*
- *128 Voices*
- *9 User Drum Voices*
- *113 User Waveforms / 84 MB Samples of oriental instruments*
- *6 Turkish Authentic Micro Tunings*

„Oriental Instruments“ is developed for the use in both traditional and modern turkish music and is based on authentic samples of oriental musical instruments. Nonetheless these special oriental instruments can be used in music styles like pop, world, chill out, ambient and whatever you can imagine.

To register for the loyalty program and the oriental soundset simply write an e-mail with the keyword „MOTIF XS Goodies“ to:

sxgoodies@easysounds.de

As soon as the registration process is complete, the MOTIF XS user will receive an e-mail from EASY SOUNDS with a password and a link where the file can be downloaded.

S90 XS / S70 XS: SOUNDPACKAGE

A free „Soundpackage“ with additional high-class content is available for S90 XS / S70 XS users.

This Soundpackage is produced by EASY SOUNDS under contract to Yamaha Music Europe and contains the following:

- Soundset „Pop & Dance“ - 128 professional Voices from the EASY SOUNDS library
- Soundset „Vocoder Dreamz“ containing 40 VocoderVoices
- A WAVpool containing 200 WAV files with a total size of 93 MB

This free soundpackage can be requested by sending an e-mail containing the keyword „S90 XS / S70 XS Soundpackage“ to:
s90xsgoodies@easysounds.de

You will receive an e-mail from EASY SOUNDS with a password and a link where the file can be downloaded.

MOTIF-RACK XS: SOUND & INFOPACKAGE

MOTIF-RACK XS users can obtain the free „Sound & Infopackage“ that’s produced by EASY SOUNDS under contract to Yamaha Music Europe.

The software package contains a Soundset (128 Voices), a WAV pool with 200 loops and audiophrases, a demo song, and a comprehensive guide plus tips & tricks.

This free soundpackage can be requested by sending an e-mail containing the keyword „MOTIF-RACK XS Sound & Infopackage“ to:

mrsgoodies@easysounds.de

You will receive an e-mail from EASY SOUNDS with a password and a link where the file can be downloaded.

S90 ES, MOTIF-RACK ES, MO6/MO8: SOUND & INFOPACKAGE

Users of the MO6 / MO8, S90 ES, and MOTIF-RACK ES can obtain a free Sound & Infopackage that's produced by EASY SOUNDS under contract to Yamaha Music Europe.

This includes the soundset „Pop Xpanded“ with 192 professional live- and arpeggio-Voices. Furthermore a comprehensive documentation and other useful tips & tricks are included.

This free soundpackage can be requested by sending an e-mail containing the keyword „Pop Xpanded“ to:

popxpanded@easysounds.de

You will receive an e-mail from EASY SOUNDS with a password and a link where the file can be downloaded.

TENORI-ON: EUROPEAN VOICE & SAMPLEBANK

Yamaha Music Europe and EASY SOUNDS provide their free soundlibrary „European Voice & Samplebank“ to all Tenori-On users.

The downloadable file (48 MB) contains the following:

- 18 Tenori-On User Voices (Samplings)
- 4 Tenori-On Demos (AllBlock-Files)
- 268 Samples in WAV-Format (19 MB)
- Comprehensive PDF documentation

This free sound library can be requested by sending an e-mail containing the keyword „Tenori-On European“ to:

tenorion@easysounds.de

You will receive an e-mail from EASY SOUNDS with a password and a link where the file can be downloaded.

FREE DRUM KITS FOR DTX900 & DTXTREMEIII

Yamaha offers free content for DTX900K, DTX950K, and DTXTREMEIII.

There are five content packages available for download:

- *Extra Content 1 - Jazz Kit (4 Drum Kits)*
- *Extra Content 2 - Rock Kit (13 Drum Kits)*
- *Extra Content 3 - Electronic Kit (15 Drum Kits)*
- *Extra Content 4 - Vintage Kit (6 Drum Kits)*
- *Extra Content 5 - Oak Kit (6 Drum Kits)*

Altogether there are 44 Drum Kits (containing 150 MB samples) available. For more information and the download links visit <http://de.yamaha.com/de/support/>

Go to the Downloads / Driver and Software section and enter the name of your drum kit model.

OCEAN WAY DRUMS DTXPANSION KIT

These three Drum Kits have been produced by Yamaha's sound designer Dave Polich and are based on the sample library from Ocean Way (Sonic Reality).

The Drum Kits feature a very complex programming containing multiple velocity layers. You can download the file at:

<http://www.dtxperience.com/dtxpansion.php>

FREE DRUM KITS FOR THE DTX-MULTI 12

Yamaha provides 25 high quality Drum Kits (75 MB) for the DTX-MULTI 12 for free download.

It is the same content that has been available for some time now for DTX900K, DTX950K, and DTXTREMEIII.

Here's an overview of the available Kits, which are divided into two files:

File 1 = Acoustic Kits

- *Jazz Maple (5 variations)*
- *Oak X Single (5 variations)*
- *Vintage (5 variations)*
- *Rock Single (5 variations)*

File 2 = Electronic Kits

- *ClasscDance*
- *Classic RX*
- *Drum'n'Bass*
- *HipHop90bpm*
- *House 128bpm*

More information and download links can be found here:

<http://download.yamaha.com>

First select your country and then enter DTX-MULTI12 into the search form.



DTX-MULTI 12 SOUNDSET: „ORIENTAL PERCUSSION“

The DTX Electronic Percussion Pad MULTI-12 uses many of the high-end features and sounds from the DTX and MOTIF series and provides an optimum tool for live drumming, productions or rehearsals.

With over 1,200 high-class sounds - including newly-developed drum, percussion and keyboard sounds - the DTX-12 MULTI enriches any musical situation. Up to 200 User Sets can be programmed and added with effects to get ready for every conceivable musical style with the best sounds around. In addition, the large 64MB Flash-ROM Wave-Memory can be filled with additional samples which then can be assigned to the Pads.

Now the soundset „Oriental Percussion“ for the DTX-MULTI 12 is available for registered users. It is provided by EASY SOUNDS on behalf of Yamaha Music Europe - free of charge.

The download package includes the following:

- 50 Patterns
- 24 Kits
- 132 User Waves (18 MB Samples)

The soundset has been designed primarily for traditional and modern Turkish music. It's based on authentic samples of oriental percussion instruments.

The oriental instruments are however well suited for use in other music styles such as Pop, World, Chill Out, Ambient, etc.

„Oriental Percussion“ was programmed by the Turkish musician and producer Mert Topel.

Since 1990 Mert Topel is working as a musician with nationally and internationally known pop and rock stars such as Tarkan (1993-2008) and many others. Mert recorded several albums as a producer of jazz, fusion, rock bands, and singers like Kirac, Mor ve Otesi, Gülden Goksen, Grizu etc. He also has his own jazz-rock band „Fenomen“, which published its first album in 2006 - with very good response from jazz lovers. Another project is a collaboration with Alper Maral in the production of an electro-acoustic-oriented album called „The Voltage Control Project“, which appeared in 2010.

The DTX-12 MULTI Patterns produced by Mert Topel should inspire the musician in the first place and serve as basis for his own music productions.

This free soundset can be requested by sending an e-mail containing the keyword „DTX-M12 Oriental“ to:

dtxmulti12@easysounds.de

The user will receive an e-mail from EASY SOUNDS with a password and a link where the file can be downloaded.

CUBASE AI TUTORIAL VIDEOS FOR REGISTERED USERS

Thanks to the cooperation between Yamaha and Steinberg most of the recent instruments and mixing desks from the Yamaha Music Production range have the DAW software Cubase AI included – for those who do not own a DAW software yet this is one good reason more to buy from Yamaha. Even more Cubase AI is a music production tool with functions which were exclusive for high-end studios not very long time ago.

Even better: European customers buying a Yamaha Music Production instrument with included Cubase AI software are qualified to request a free English language tutorial CD from ASK Video containing 23 videos on how to use Cubase AI4.

The CD is English language only and only available as long stocks last. So better be quick – request your CD by sending an e-mail containing the serial number of your Yamaha instrument and your name and address to:

musicproduction@yamaha.de

Important note: This CD-ROM can not be shipped outside Europe!



OPTIONAL SOUNDSETS FOR MOTIF / MOXF / MOX / MO AND S SERIES

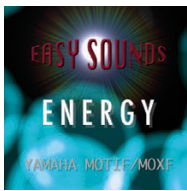

"ENERGY"

Sounds for electronic, modern pop, dance, dubstep, electro house, and related styles of music. With Energy important elements of the current electronic music are finally available for the MOTIF. Rapid arpeggios, wobbling synths, electric bass, and drum beats in variable tempos are essential features of this set



"NATURE OF CHILL"

Exquisite Voices and Performances for chill out, lounge, ambient, electronic, and related musical styles of popular music. In addition to broad, effective and atmospheric synthesizer sounds also remakes of traditional instrument sounds from the fields of piano, electric piano and guitar are offered

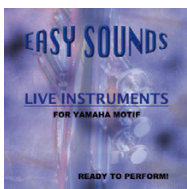

"LIVE INSTRUMENTS"

Voice and sound collection with high-quality sounds of the categories piano, electric piano, clavinet, organ, Mellotron, strings, brass section, synth. Popular selection of instruments that are always required by keyboard players in bands. In addition, the sound library contains punchy drum sounds and arpeggio Performances that offer inspiration and ample opportunities for improvisation with accompaniment and idea material for productions

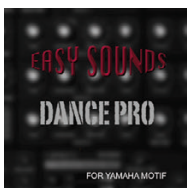

"DANCE PRO"

Top-current, powerful, and assertive dance Voices, programmed by top international sound designers. A special feature are the audio / MIDI arrangements, where synth Voices and drum loops are combined. These arrangements can be used as a starting point for your own dance tracks



"EVOLVING SOUNDSCAPES"

Inspiring collection of atmospheric and dramatic Voices and Performances on the basis of a newly created sample library. High-quality FX, synth and drum samples, pads, and musical effects with impressive atmosphere and motion-rich sound structures, spherical and spectacular sound effects for cinematic and ambient productions



"PHAT ANALOG II"

Timeless Voice and sound collection with an emulation of popular sounds from Oberheim synthesizers (OBX, OB8, Matrix12 ...) and the Jupiter-8. The ultimate analog extension for the MOTIF! Polyphonic synth sounds like synthbrass, synthstrings, pads, and synthcomps are the main content. However, leadsynths for synthpop, sequencer, arpeggio, and FX sounds can also be found in this sound library

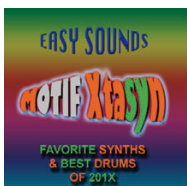

"XTASYN"

Up-to-date synth and drum sounds for dance, trance, pop, and electronic. Phat leads & synthcomps, pads, FX. Special attack Waveforms for punchy sounds



"FM XPANDED – VOL. 1: ELECTRIC PIANO & CLAVINET"

Sample-based FM sounds with very high dynamic and authenticity, which are heavily based on classic DX7 sounds, but also offer new and innovative creations



„PHAT ANALOG“

Synthleads, pads & more! Timeless Voice and sample library with a Minimoog emulation (Leadsynths) and JP-8 sounds. The ultimate analogue extension!



„CHILL XPERIENCE“

Soundset for Chill Out, Lounge, Ambient, New Age, Electronic, and related genres. These sounds offer a high level of musical inspiration



„DRUM PERFORMER“

Lavishly produced 'Real Drums' for extremely realistic sound; dry, fat and punchy. Extreme range of sounds achieved by different recording techniques



„STAGE & STUDIO“

The ultimate top 40 and live set! Contains the most important standard instruments and synth sounds for live musicians. Outstanding performance and power



„ORGAN SESSION“

This set is an impressive emulation of the legendary Hammond B3. Smacky organ sounds with concise key click and controllable percussion. Perfect for Rock, Pop and Jazz

GENERAL INFORMATION

The above soundsets are available for the following devices:

- MOTIF XF, MOXF, MOTIF XS, MOTIF-RACK XS, S90 XS / S70 XS, MOX, MOTIF ES, MOTIF-RACK ES, S90 ES, MO6, MO8.

- Some soundsets are not available in allen formats.

The most recent soundsets are offered primarily for MOTIF XF, MOXF, and MOTIF XS.

Each soundset contains 128 Voices. Depending on the device, additional content such as Performances, Samples, User Arpeggios, and WAV Loops are included..

Further details can be found on www.easysounds.de

Price per soundset = 35,- EUR

The soundsets are available from:

EASY SOUNDS – Peter Krischker

vertrieb@easysounds.de

http://www.easysounds.de

IMPRINT & FURTHER LINKS

IMPORTANT WEBSITES FOR MOTIF USERS

Official international Yamaha website for synthesizers including a comprehensive download section

www.yamahasyth.com

Official website of Yamaha Music Europe GmbH

www.yamaha-europe.com

American MOTIF support website including message board + KEYFAX webshop + „XSpand Your World“ downloads

www.motifator.com

EASY SOUNDS website + webshop sounds and USB sticks for Yamaha synths

www.easysounds.de

John Melas MOTIF Site Editor softwares for the MOTIF series

www.jmelas.gr/motif

Cool Webinars

Support for Yamaha synthesizers and more

www.cool-webinars.com

YAMAHA MUSIC PRODUCTION GUIDE

The official News Guide about the Yamaha Music Production product series and Computer Music Instruments

Published by

EASY SOUNDS

Peter Krischker

Am Langberg 97 A

D-21033 Hamburg

Telefon: +49 40 - 738 62 23

In cooperation with

Yamaha Music Europe GmbH

Siemensstraße 43

D-25462 Rellingen

Telefon: +49 41 01 - 30 30

e-mail: motifnews@easysounds.de

MUSIC PRODUCTION GUIDE HISTORY

You can download all English editions already published as one single ZIP file using this link to the EASY SOUNDS website:

www.easysounds.eu/NewsGuidesEN.zip

A total summary of all topics ever discussed in the Music Production Guide can be found here:

www.easysounds.eu/mpghistory/history_en.htm

The free Music Production Guide contains news, tips & tricks, software offers, and interviews on and around Yamaha synthesizers of the MOTIF series, MOX/MOXF series, MX series, reface, S series, MO series, MM series, Tenori-On, and articles about recording, software, and Computer Music Instruments.

You can subscribe or unsubscribe to the free Music Production Guide by sending an informal e-mail to:

motifnews@easysounds.de

CLARITY IN SOUND AND DESIGN



HS STUDIO MONITORS

NOW ALSO AVAILABLE IN A STUNNING WHITE FINISH



••• A great new look as pure as their sound: of course with the same features as the legendary black originals ••• 2-way bi-amped HS5 (70W), HS7 (95W) and HS8 (120W) studio reference monitors that are ideal for mixing and music production, delivering an exceptionally smooth, flat and – most importantly – accurate response ••• For more bottom end the HS monitors can be combined with the HS8S (150W) subwoofer •••

