



# MODERN PENTATHLON 2014 COMPETITION RULES

## 5. EVENT RULES – COMBINED EVENT-RUNNING/SHOOTING

### PART A      THE EVENT

#### 5.1            PRESENTATION OF THE EVENT

- 1            Description
- 2            Target Models

#### 5.2            AUTHORITIES

- 1            Combined Event Director
- 2            Shooting Director
- 3            Range Officer
- 4            Target Officer
- 5            Shooting Judge
- 6            Running Director
- 7            Course Judges
- 8            Marshall
- 9            Starter
- 10          Deputy Starter
- 11          Starter's Assistants
- 12          Arrival Judges
- 13          Timekeepers
- 14          Announcer
- 15          Penalty Stop Area Judges
- 16          Equipment Controllers

#### 5.3            ORGANISATION AND SCHEDULE

- 1            General Aspects
- 2            Starting Order
- 3            The Series
- 4            Warming up, Zeroing and Preparation Time

#### 5.4            CONDUCT OF THE COMPETITION

- 1            Particular Safety Regulations
- 2            The Start
- 3            False Start
- 4            Shooting Series
- 5            Running Course
- 6            The Finish
- 7            Timing

#### 5.5            SCORING



## **5.6 INFRINGEMENTS AND PENALTIES**

- 1 **10 seconds**
- 2 **Elimination**
- 3 **Disqualification**

## **PART B INDIVIDUAL EQUIPMENT**

### **5.7 CLOTHING**

### **5.8 EQUIPMENT – THE PISTOL**

## **PART C EQUIPMENT PROVIDED BY THE LOC**

### **5.9 THE FOP**

- 1 **The Venue**
- 2 **The Different Areas**
- 3 **The Running Course**
- 4 **Shooting Range Requirements**

### **5.10 OTHER EQUIPMENT**

- 1 **Target Requirements**
- 2 **Mechanical Pellet Target**
- 3 **Electronic Pellet Target**
- 4 **Laser Hit Target**
- 5 **Laser Precision Target**
- 6 **Indicators (Result Display Lights)**

### **5.11 LOC CONTROL DEVICES AND TOOLS**

## **PART D ANNEXES**

**Appendix 5A PENALTY TABLE (see Article 5.6)**

**Appendix 5B1 POINTS TABLE – Individual and Relay: Seniors, Juniors, Under 19 (YA),  
Relay: Under 17 (YB)**

**Appendix 5B2 POINTS TABLE – Individual: Under 17 (YB)**

**Appendix 5B3 POINTS TABLE – Individual, Relay: Under 15 (YC), Relay: Under 13 (YD)**

**Appendix 5B4 POINTS TABLE – Individual: Under 13 (YD), Relay: Under 11 (YE), Under 9  
(YF)**

**Appendix 5B5 POINTS TABLE – Individual: Under 11 (YE), Under 9 (YF)**

## **FIGURES**

**Figure 1 - Indoor or Night Range Light Requirements (in Lux)**

**Figure 2 – The Pistol Grip**

**Figure 3 – Bends in the Grip**

**Figure 4 – The Thumb in the Grip**

**Figure 5 – Measuring the Weight of the Trigger Pull**

**Figure 6 – Mechanical Targets**

**Figure 7 – Electronic Pellet Target**

**Figure 8 – Laser Target**

**Figure 9 – Laser Precision Target**

**Figure 10 – Indicators (Result Display Lights)**

**Figure 11 – The Precision Target**



## 5 RULES FOR COMBINED EVENT RUNNING AND SHOOTING

### PART A THE EVENT

#### 5.1 PRESENTATION OF THE EVENT

The Combined Event consists of shooting and running. The shooting involves pistol shooting in series at 10 metres in a range equipped with targets (as in Article 5.1.2 below) each of the four series of shooting being followed by Running for the distances shown immediately below.

##### 5.1.1 The Combined Event sequence

	INDIVIDUAL		RELAY			INDIVIDUAL		RELAY	
	DIST	D TOT	DIST	D TOT		DIST*	D TOT	DIST*	D TOT
Sen	4x800	3200	2x2x800	3200m	YC	2x800	1600	2x2x400	1600m
Jun	4x800	3200	2x2x800	3200m	YD	2x400	800	2x1x400	800m
YA	4x800	3200	2x2x800	3200m	YE	1x400	400	2x1x400	800m
YB	3x800	2400	2x2x800	3200m	YF	1x400	400	2x1x400	800m

\*Recommended distances

In YOG Qualification competitions, only the distance for Youth A will be used.

##### 5.1.2 Target Models

4 main types of target models are used for Modern Pentathlon competitions.

- i) PT - Pellet Target
  - a) MT - Mechanical Pellet Target
  - b) ET - Electronic Pellet Target
- ii) LT - Laser Target
  - a) HT - Hit Laser Target
  - b) LPT - Laser Precision Target

#### 5.2 AUTHORITIES

5.2.1 The LOC must appoint a **Combined Event Director**, who is overall in charge of the Combined Event. The Combined Event Director:

- i) must appoint two deputy combined event directors, one for running and one for shooting;
- ii) is a member of the Competition Jury;
- iii) is responsible for the overall correct conduct of the combined event;
- iv) permits the pentathletes to start warming up.

5.2.2 **Deputy Combined Event Director for Shooting (Shooting Director)** who is in charge of:

- i) appointing and supervising: the Range Officers, Shooting Judges, Target Officers, Equipment Control Officers and the Range Personnel;
- ii) the correct conduct of the shooting event;
- iii) the rapid correction, in conjunction with the appointed Range Officers, of any equipment failure and for ensuring that the necessary experts and material are available to operate the range;
- iv) informing the pentathletes and coaches of the final minute and 30 seconds remaining of warming up time on the shooting range, which ends 3 minutes before start of competition;
- v) communicating all reported irregularities and penalties to the TDs/NTOs.

5.2.3 **Range Officers**, appointed one per 9 to 12 firing points, are responsible for:

- i) checking that pentathletes use the right firing points;
- ii) checking the names and start numbers of pentathletes to ensure that they conform to the combined event schedule, start list, scorecards and range register;
- iii) controlling pentathletes' clothing (shirts with name, numbers, armband, headphone, etc.);
- iv) verifying that pentathletes' pistols have been inspected and approved by the Equipment Control Section;



- v) checking that pentathletes assume the correct shooting position;
- vi) checking that the pentathletes do not disturb the other pentathletes;
- vii) applying and checking (in collaboration with the Shooting Judge) any 10 second penalty imposed on a pentathlete at their shooting station;
- viii) supervising the correct operation of the targets;
- ix) maintaining order on the range, with particular attention to safety;
- x) ensuring the recording of all irregularities, disturbances, penalties;
- xi) communicating all irregularities and penalties to the Shooting Director.

5.2.4 **Target Officers** must:

- i) prepare the shooting targets before the competition;
- ii) assist the Shooting Director during the entire competition.
- iii) assist with pistol testing and help the Equipment Controllers.

5.2.5 The Shooting Director must appoint one **Shooting Judge** for each shooting station in Category A competitions, and 1 Shooting Judge per 2 shooting stations in all the other competitions. The Shooting Judges are responsible for:

- i) observing all shots fired;
- ii) ensuring that each pentathlete using a pellet pistol completes the loading sequence (fully closes the breech) with the pistol in contact with the shooting table; and that each pentathlete using a laser pistol touches the pistol on shooting table between each shot;
- iii) after each shooting series, checking that the pistols are safe. A pellet pistol is safe when untouched, placed on the shooting table pointing down the range, in an unloaded position (no pellet in the barrel and in an open position). A laser pistol is safe when untouched and placed on the shooting table pointing down the range;
- iv) checking that each pentathlete using a mechanical target resets the target before the start of each shooting series;
- v) informing the Shooting Director immediately as to any infringement of the rules;
- vi) applying and in collaboration with the Range Officer checking any 10-second penalty imposed on a pentathlete at the shooting station.
- vii) With all pistol models, starting the stop-watch at the first attempted shot. The Shooting Judge must inform the pentathlete if the target lights do not indicate the first shot. The Shooting Judge must inform the pentathlete 5 seconds before the 50 second time limit expires by saying "Position XX 5 seconds remain", and giving the command "Position XX GO", to the pentathlete when the 50 second time limit has expired.

5.2.6 The **Deputy Combined Event Director** for Running (the **Running Director**) is responsible for

- i) appointing and coordinating the activities of all Running Officials: Course Judges, Marshall, Starter, Deputy Starters, Starter's Assistants, Arrival Judges, Timekeepers, Recorders, Announcers, Last Penalty Stop Area Judges;
- ii) supervising the building of the course and the conduct of the event;
- iii) ensuring that the course or track and all equipment, including marketing banners, are in accordance with UIPM Rules;
- iv) ensuring that UIPM Rules are observed. The Running Director has authority to penalise pentathletes or other persons infringing these Rules;
- v) appointing special judges to coordinate the application of penalties from the starting area, shooting range penalties and the last penalties stop area.

5.2.7 The **Course Judges** are assistants of the Running Director. They do not have authority to make final decisions. They are placed by the Running Director so that they may best observe the running closely. In case of a foul, deviation from the course, unauthorised assistance or any violation of these rules by anyone they shall immediately report this to the Running Director orally and later in writing.

5.2.8 The **Marshall** has full charge of the start/finish area and the shooting range area. The Marshall must not allow any person other than the officials and competing pentathletes to enter or to remain there. The Marshall can be assisted by one or more assistants.

5.2.9 The **Starter** has entire control of the pentathletes while on their marks and is the sole judge of any fact connected with the start of the race. The Starter is responsible for synchronising



their own, the Timekeepers' and Deputy Starters' watches and for giving the start signal to the first pentathlete when they are due to start and informing them before the start as to the time remaining before the start. The Starter will apply false start penalties and inform the Running Director who in turn will inform the Announcer.

- 5.2.10 The **Deputy Starters**, one for each start line, are under the supervision of the Starter. Deputy Starters must not have physical contact with the pentathletes. Their duties are to ensure that each pentathlete starts on time.
- 5.2.11 The **Starter's Assistants**, one for each start line, must check the pentathletes in the start-lanes and ensure that the pentathletes are lined up in correct order, at the right time, wearing the correct clothing, with the correct name and national code, and with numbers properly fastened front and back. Any violation of these rules must be reported immediately to the Running Director.
- 5.2.12 The **Arrival Judges** are responsible for registering the arrival order of the pentathletes at the finish line. Two groups of two judges working independently are needed.
- 5.2.13 The **Timekeepers** must use their stopwatches or manually operated electronic timers with or without digital readouts. All such timing devices are termed "watches" for the purpose of these Rules. Whether automatic timing is used or not, there should always be three Timekeepers, one of whom shall be the **Chief Time Keeper**. Their responsibility is to record the times of the pentathletes.
- 5.2.14 The **Announcer** is responsible for informing the public of the names and numbers of the pentathletes taking part in the combined event and other relevant information such as intermediate times. The Announcer must broadcast the first part of the count down to the start of the event up until one minute to departure, after which the countdown is under the control of the Starter. The results (placing, times and points) must be announced at the earliest possible moment after receipt of the information.
- 5.2.15 In the last **Penalty Stop Area two Judges** stay at the special penalty area located between 400-600m after the end of the shooting range, ready to apply penalties that cannot be applied at the shooting station.
- 5.2.16 **Equipment Controllers** must inspect, measure and verify the laser shooting equipment under the guidance of a UIPM laser expert, and test the weapons and other shooting equipment and clothing.

### 5.3 ORGANISATION AND SCHEDULE

#### 5.3.1 General Aspects

Competition materials/equipment and clothing includes all the materials, equipment, competition gear and clothing which the pentathlete uses during the combined event. These materials, including any advertising, must be controlled before the competition.

- i) Equipment inspections must normally be organised before the competition following the start of the riding event or after the second event in case of semi-finals. Pistols may be tested and controlled the day before the competition in which case the pistols will be kept by the LOC or sealed until warm-up.
- ii) Pentathletes shall report at the materials/equipment and clothing inspection area at the scheduled time in order to have their equipment checked and marked, and their clothing inspected.
- iii) A Maximum of 1 reserve pistol or cylinder per pentathlete is to be brought to the Equipment Control Area and clothing checkpoint for inspection and marking. The reserve pistol must be taken directly to the range and deposited closed in the pentathletes' box at their own shooting station. The range staff will not permit the deposit of the reserve pistol after the warming up time has ended.
- iv) The Equipment Control Area consists of 3 Equipment Controllers who are responsible for testing the weapons and other shooting equipment.
- v) The Equipment Control Area must provide a complete set of gauges and instruments for equipment control before the event.



- vi) In case a pistol ceases to function the pentathlete can use another pistol provided this reserve pistol, provided by the pentathlete, has previously been inspected, approved and marked by the Equipment Control Section.
- vii) Pistols are checked as to calibre, weight, single shot and dimensions. All accepted pistols are marked as being allowed for competition. Laser pistols are checked also in the parameters according article B.5.8.2 ii.
- viii) All approved equipment must be marked with a seal or sticker and recorded on the control card. The Equipment Control Area must register the name of the pentathlete, the make (manufacturer), type and serial number of the pistol. Such approval is valid only for the relevant event. In the case of laser containers, the seal/sticker should be placed so that the laser container cannot be interfered with after the equipment test.
- ix) After the equipment has been approved, the pistol must not be modified or adjusted at any time before or during the event in any way that would conflict with the Combined Event Rules, unless with the agreement and under the supervision of the Range Officer.
- x) Any unapproved alterations or exchange will incur a penalty. If there are any doubts regarding any alteration, the pistol must be returned to the Equipment Control Area for re-inspection and approval.
- xi) Appropriate CO2 and air must be available on the weapon control area for the pentathletes using containers with air (as long as such containers are in use).
- xiii) During a Relay competition only, a competing pentathlete's pistol may be laid on the shooting range table top. Only the pentathletes are authorised to move their pistols from the pistol storage under the table to the shooting table top.

### 5.3.2 Starting Order

Each pentathlete's score in points after the previous Pentathlon disciplines is totalled. These scores are converted to create staggered starting times for the Combined Event. A difference of 1 pentathlon point equates to 1 second running. The pentathlete with most points will be the first to start at the Start Signal (0'00") and will shoot at station No 1.

### 5.3.3 The Series

The Shooting competition is in series. Each series consists of hitting 5 targets with an unlimited number of shots in a maximum time of 50 seconds on a target with a valid zone of dimension 59.5mm. If after 50 seconds one or more targets have not been hit (or the pentathlete has not hit the valid zone 5 times) the pentathlete may start running without being penalised, provided the pistol is made safe in accordance with Rule 5.4.1 x.

### 5.3.4 Warming up, Zeroing and Preparation Time

- i) The LOC will confirm the format of the warm up, zeroing and preparation time at the Technical Meeting.
- ii) The Combined Event Director asks pentathletes to enter their shooting stations. Each shooting station corresponds to the pentathlete's starting position. Pentathlete No1 shoots at station No1, pentathlete No 2 shoots at station No 2 and so on.
- iii) Athletes are not allowed to take their pistols out of their box until the Command 'uncase and prepare weapons' is given by the Shooting Director. The Shooting Director will give the command "Preparation – START". Pentathletes are then allowed to shoot. The time of the preparation must not be longer than 8 minutes. One coach per nation is allowed to assist their athletes during this preparation time, after which the coaches have to return to their reserved area.
- iv) After the Shooting Director has confirmed that all the pistols and targets are working properly, he will give the Command "STOP". Pistols must be placed on the table in a safe position.
- v) Then the warm-up will start, after the appropriate command ("12 minutes Warm Up - START") by the Shooting Director.
- vi) With pellet pistols, zeroing should only take place on the range using 10 metre air pistol paper targets. Paper targets must be placed at the same level and at the same distance from the firing point on the right side of the competition target.
- vii) With Electronic Targets, if zeroing paper targets are placed on the real target the 20 minute warm up must be divided into two sessions: 7 minutes on the zeroing/paper targets, 1 minute break to change the targets, 12 minutes on the electronic target:
- viii) During the warm up period pentathletes may run and shoot an unlimited number of shots. The use of constant beam (for laser pistols) is only authorised in the warm-up.



- ix) At the Shooting Station, pentathletes may use water and towels, which must be kept under the table with the reserve pistol and any binoculars used during warm up. No video camera is allowed in the shooting station.
- x) The Shooting Director will inform the pentathletes of the last 5 minutes, the last minute and 30 seconds remaining of the shooting session warm up.
- xi) After the warm up and before the start signal pistols must be on the assigned shooting station, not charged and without pellets in the chamber. The reserve pistol must be in its box, under the shooting table.
- xii) During the warm up coaches may assist and communicate with pentathletes from a specially marked area for coaches outside the shooting stations and the running corridor.
- xiii) The Shooting warm up session must be ended 3 minutes before the start of the combined event competition. At the end of the warm up coaches must clear the Field of Play and the pentathletes must go to the Combined Event starting line.

## 5.4 CONDUCT OF THE COMPETITION

### 5.4.1 Particular Safety Regulations

- i) Safety Regulations are to be established by the LOC in accordance with the respective national laws of the organising country. The LOC is responsible for informing all event participants of these rules and providing for their application.
- ii) The safety of all event participants and spectators requires self-discipline, careful attention to pistol handling and caution in moving about the competition area by everybody concerned. It is the responsibility of pentathletes and team representatives to ensure they handle their pistols (and cartridges) safely and efficiently.
- iii) The UIPM TD/NTO, Shooting Director or Range Officers may stop the combined event at any time in the interest of safety. Pentathletes and team officials must immediately notify Range Officers of any situation that may be dangerous or which may cause an accident.
- iv) Dry firing (i.e. the release of an air pistol trigger mechanism by a fitted device which enables the trigger to be operated without discharging any propellant air or gas) and aiming exercises are permitted, but only upon authorisation of the Combined Event Director or Shooting Director and only on the firing line.
- v) Pistols must not be touched when any person is forward of the firing line.
- vi) Pellet pistols must be made safe by opening the cocking handle and/or loading part.
- vii) At the firing station, pistols must always be pointed in a safe direction. In the combined event area, when the pistol is not on the firing point, it must always be in its box.
- viii) Pistols may be loaded only at the firing station, and only after the command to 'uncase and prepare weapons' is given and only after the command "warming up START" is given.
- xi) If the command "STOP" is given, all pentathletes must stop shooting immediately and place the pistol on the table pointing in a safe direction, not cocked and untouched.
- x) After the last shot of each shooting series the pentathlete must ascertain before leaving the firing point, and the Range Officer will verify that there are no pellets in the chamber. Pellet pistols must be made safe by opening the cocking handle and/or loading part. Laser pistols are automatically in "safe mode" (the shot cannot be triggered) if the pentathlete does not "reload" (reset the trigger) and must be rendered safe in this way.

### 5.4.2 The Start

- i) The handicap start must use three gates: two gates A and B and one additional Penalty ("P") Gate. The Start Line for running shall be denoted by a white line 5cm wide on the ground.
- ii) Pentathletes with a handicap after the previous events of more than 2 minutes will start in a pack start at 2'00".
- iii) The Combined Event has a staggered start at the beginning of the competition (and starts from the shooting line for pentathletes who do not succeed in the shooting series after 50 seconds).
- iv) In the event of a false start from the shooting line the same rules for a false start will be applied: a 10 second penalty for a false start and disqualification in the case of a blatant attempt to start too early
- v) Pentathletes are responsible for knowing their own start time, for being at the start line on time and for starting on time.



- vi) The Announcer will announce “10 minutes” and “5 minutes” prior to the start of the combined event. The Announcer, under the command of the Combined Director, will declare warming up on the shooting range finished. All pentathletes must be at the start area and the Starter/Starter Assistants will begin lining up the pentathletes. One minute before the start, all pentathletes must be at the corresponding gates assembled in the order of their start time.
- vii) The Starter will announce – “**One minute to start**”; “30 seconds”, “20 seconds” and “10 seconds to the Start.” After the OK has been given by the Timekeepers and the Combined Event Director, the Starter will tell the first pentathlete “**Take your Marks**”, followed by the start signal. All timing equipment will start at the start signal. At the start area, a start clock must be placed so that it is easily readable from the start line and by the timekeepers. The start time for the first pentathlete will be ‘00.00’. Pentathlete No 1 starts at time ‘00.00’. Pentathlete No 2 starts at ‘x’ seconds depending on the points difference at that stage, and so on.
- viii) Pentathletes must run a short distance ( $\pm 20$  metres) to the shooting range and start the first shooting series of 5 targets.

#### 5.4.3 **False Start**

- i) The Starter/Announcer must immediately announce to the pentathlete and spectators if a pentathlete that has started too early and inform them of their false start.
- ii) A pentathlete starting late will not be penalised, but their time will be taken from the moment they should have started according to the start list.
- iii) A false start occurs if a pentathlete crosses the start line before the official start time. Before the start both feet must be behind the start line.

#### 5.4.4 **Shooting Series**

- i) Each pentathlete must always use their allocated shooting station. Each team must use always the same designated target(s).
- ii) Pentathletes are responsible for shooting on the correct target. When shooting with pellet pistols it is the pentathlete’s responsibility to reset the mechanical targets.
- iii) The pentathlete must stand with both feet on the ground, without support, completely within the shooting station. The entire pistol must be held and fired with one hand only. The unarmed hand must not give support to the unarmed arm or hand.
- iv) With pellet pistol, each shot must be loaded with the pistol in contact with the shooting table. With laser pistol the pistol must touch the table between every shot.
- v) Only after successfully completing each shooting series, or 50 seconds has elapsed, may the pentathlete start running. After the last series the pentathlete must cross the running finish line.
- vi) Malfunctions are not taken into consideration. Should a pistol cease to function, the pentathlete may use the reserve pistol or another cylinder that must have also been approved by the Equipment Control Section. If a shot has not fired due a malfunction, the pentathlete may use the reserve pistol without interruption. If the reserve pistol also does not work the pentathlete must wait at the shooting station until the 50 second shooting time has expired before starting running.

#### 5.4.5 **Running Course**

- i) Pentathletes must follow the course from crossing the start line, going to the shooting range for each shooting series and, having completed the shooting, cross the finish line.
- ii) If informed by a Judge and announced by the sound system, the pentathlete must stop and remain in the Last Penalty Stop Area for the time indicated.
- iii) During the race no pentathlete may accept any physical assistance or refreshment. In exceptional circumstances this can be allowed if so decided by the Pentathlon Director, Combined Event Director and Technical Delegate. Running by a non-competitor with or behind a pentathlete may be unauthorised assistance. A hands-on medical examination by official medical personnel during the progress of the event and verbal or other communication from a person not on the course is not unauthorised assistance.
- iv) A pentathlete/team must complete the course.





#### 5.4.6 **The Finish**

The last 50 metres shall be straight and well visible for TV cameras and spectators. The finish line shall be denoted by a white line on the ground 5cm wide. Pentathletes will be timed and placed in the order in which any part of their torso (as distinguished from the head, neck, arms, legs, hands or feet) reaches the vertical plane of the nearer edge of the finish line.

#### 5.4.7 **Timing**

Times for all finishers shall be recorded. Three alternative methods of timekeeping are recognised as official: Manual Timing; Fully Automatic Timing obtained from a Photo Finish System; Timing provided by a Transponder System. In Category "A" Senior UIPM competitions manual timing is not allowed.

When automatic judging and timing equipment is provided, it must be used to determine the winner, placings and times for each athlete. The results and time so determined has precedence over the decisions of Timekeepers. In the case of a breakdown or mechanical failure, the timekeepers' decisions will take precedence and reference must be made to all manual times recorded. In all UIPM Senior Category "A" Competitions video recording is compulsory at the finish line.

- i) Manual Timing:
  - a) Timekeepers shall be in line with the finish and where possible.
  - b) Timekeepers shall use manually operated electronic timers with digital readouts.
  - c) Three official Timekeepers (one of whom shall be the Chief Timekeeper) shall time all the athletes.
  - d) Each Timekeeper shall act independently and without showing his watch to, or discussing his time with, any other person, shall enter his time on the official form and, after signing it, hand it to the Chief Timekeeper who may examine the watches to verify the reported times.
  - e) For all manually-timed races, times shall be read and recorded as an exact 1/10th of a second.
  - f) If, after converting as indicated above, two of the three watches agree and the third disagrees, the time recorded by the two shall be the official time. If all three watches disagree, the middle time shall be official. If only two times are available and they disagree, the greater time shall be official.
  - g) The Chief Timekeeper, acting in accordance with the Rules mentioned above, shall decide the official time for each athlete and provide the result for distribution.
- ii) Fully Automatic Timing obtained from a Photo Finish System:
  - a) Fully Automatic Timing and Photo Finish System approved by UIPM should be used at all Olympic Competitions. It shall be started automatically by the Starter.
  - b) The System must record the finish through a camera with a vertical slit, positioned in the extension of the finish line, producing a continuous image. The image must also be synchronised with a uniformly marked time-scale graduated in 1/100th of a second.
  - c) The placing of the athletes shall be identified from the image by means of a cursor with its reading line perpendicular to the time scale.
  - d) The System must automatically determine and record the finish times of the pentathlete and must be able to produce a printed image which shows the time of every pentathlete.
  - e) There should be at least two photo finish cameras in action, one from each side. Preferably, these timing systems should be technically independent, i.e. with different power supplies and recording.
  - f) The Running Director shall determine the placing of the pentathletes and their official times. He shall ensure that these results are correctly entered in or transferred to the competition results system and conveyed to the Results team.
  - g) Times from Photo Finish System shall be regarded as official unless for any reason the appropriate official decides that they obviously must be inaccurate. If such is the case, the times of the back-up Timekeepers, if possible adjusted based on information on time intervals obtained from the Photo Finish image, shall be official. Such back-up Timekeepers must be appointed where any possibility exists of failure of the timing system.
  - h) Times shall be read and recorded from the Photo Finish image as follows; the time shall be read to 1/100th of a second and recorded to 1/10th of a second.



- iii) Timing provided by a Transponder System:
  - a) None of the equipment used at the start, along the course or at the finish line should constitute a significant obstacle or barrier to the progress of a pentathlete.
  - b) The weight of the transponder and its housing carried on the pentathletes' uniform, bib or shoe is not significant.
  - c) The System is started by the Starter's gun or synchronised with the start signal.
  - d) The System requires no action by an athlete during the competition, at the finish or at any stage in the result processing.
  - e) The resolution is 1/10th of a second (i.e. it can separate athletes finishing 1/10th of a second apart). For all races, time shall be read to 1/10th of a second and recorded to the whole second.
  - f) When transponders are used on the feet Article 5.4.7 still applies.

## 5.5 SCORING

500 Modern Pentathlon points are awarded for obtaining the following times  $\pm 1$  point for each second faster or slower.

	Individual		Relay	
	Distance	500 pts	Distance	500 pts
Senior, Junior, Under 19 (YA)	3200m	13'20"	3200m	13'20"
Under 17 (YB)	2400m	10'30"	3200 m	13'20"
Under 15 (YC)	1600m	7'40"	1600m	7'40"
Under 13 (YD)	800m	5'20"	800m	5'20"
Under 11 (YE)	400m	4'00"	800m	5'20"
Under 9 (YF)	400m	4'00"	800m	5'20"

## 5.6 INFRINGEMENTS AND PENALTIES

5.6.1 A pentathlete is penalised by a time penalty of **Ten Seconds** for each of the following offences:

- i) contravening clothing regulations;
- ii) modifying the dimensions of the start numbers;
- iii) a false start;
- iv) not placing the pistol safely on the table after warming up has ended and after each shooting series\*;
- v) with pellet pistol, not loading each shot with the pistol in contact with the shooting table; with laser pistol, not touching the shooting table between each shot\*;
- vi) if a coach during the warming up is outside the designated coaches area and assists a pentathlete: for the first time, a warning. Any subsequent offence, a 10 second penalty for the pentathlete;
- vii) For the second time removing their pistol(s) from the box/case before the official warming up period has started. The first breach will result in a warning;
- viii) starting the running leg before the shooting time has expired without having completed successfully each shooting series\*;

\* These penalties are paid at the shooting range, with the exception of the final shooting series where they are paid in the Last Penalty Stop Area.

5.6.2 A pentathlete is **eliminated** for:

- i) not completing the course;
- ii) deviation, deliberate or not, from the course which in the opinion of the Course Judge gained a material advantage;
- iv) unauthorised assistance, if not disqualified, at the discretion of the Competition Jury;
- v) using an unapproved pistol;
- vi) shooting on the wrong target;
- vii) not stopping at the last stop penalty area when instructed by an official;
- vii) using constant beam during the competition series and/or audio communication outside preparation and warm up time.

5.6.3 A pentathlete is **disqualified** for:

- i) modifying or adjusting an officially approved pistol so that it violates the rules;
- ii) exchanging their pistol in violation of the rules;
- iii) a blatant attempt to start too early;



- iv) jostling, running across or obstructing another pentathlete so as to impede their progress.

## **Part B INDIVIDUAL EQUIPMENT**

### **5.7 CLOTHING**

- i) A pentathlete must wear athletic clothing. In Category A competitions, pentathletes from the same country must wear matching uniform.
- ii) The pentathlete must wear a top with their name clearly visible and professionally made on the back of the top, below which is the NF code, of a size between 7-12 cm and in a contrasting colour to the colour of their shirt.
- iii) Pentathletes must compete with athletic shoes, with or without spikes. Any spike restrictions must be advised by the LOC in their invitation letter.
- iv) The LOC is responsible for providing every pentathlete with two start numbers.
- v) The numbers must be worn on front and back above waist height and be visible in all weather conditions. Size 1 (maximum height 10cm and width 15cm) shall be worn on the Back and Size 2 (maximum height 20cm and width 20cm) on the front.
- vi) The pentathlete or team who is in first place before the combined event shall be assigned No 1, the second place pentathlete/team, No 2, and so on.
- vii) No pentathlete will be allowed to take part in a competition without appropriate numbers.
- viii) It is forbidden for pentathletes to modify the dimensions (size and width) of the start numbers given by the LOC.
- ix) Wristbands, taping or similar items that might provide support to the shooting hand are prohibited on the hand, elbow and arm.
- x) A sports watch is permitted on the non-shooting hand.
- xi) Radios, tape recorders or any type of sound-producing or communication systems are prohibited. Devices whose sole function is noise reduction may be worn.
- xii) It is strongly recommended that current Olympic and World Champions wear clothing, vests or armbands which identify their Champion status to spectators.

### **5.8 THE PISTOL**

#### **5.8.1 Pellet Pistol**

- i) Only single shot pistol is allowed without any form of magazine or clip.
- ii) Only calibre 4.5mm (.177") projectile made of lead or other soft material is permitted.
- iii) The weight of the pistol with all accessories must not exceed 1500 grams. For Masters, Seniors, Juniors and Under 19 (YA) competitions, the minimum total weight of the pistol is 1kg (tolerance 5%). For under 17 (YB) Competitions, the minimum weight of the pistol is 800 grams (tolerance 5%). The weight of the trigger pull must be a minimum of 500 grams.
- iv) The overall size of the pistol is limited to dimensions which permit it to be enclosed completely in a rectangular box with inside dimensions of 420mm x 200mm x 50mm. A manufacturing tolerance of + 1.0mm in the dimensions of the box is permitted. The minimum overall size is 20% of the above dimensions (336mm x 160mm x 40mm) with the same tolerance.
- v) Ported barrels and performance barrel attachments for air pistols are allowed providing the pistols comply with all other requirements, including dimensions.
- vi) Only open sights are allowed. Optical, mirror, telescope, laser-beam, electronically projected dot sights et cetera are prohibited. Any aiming device programmed to activate the firing mechanism is prohibited. No protective covering is permitted on front or rear sights.
- vii) No part of the grip or accessories may encircle the hand. The heel rest must extend at an angle not less than 90° to the grip. Any upward curvature of the heel and/or thumb rests and/or downward curvature of the side opposite the thumb is prohibited (see figure 2). The thumb support must allow the free upward vertical movement of the thumb. However, curved surfaces on the grips or frame, including the heel and/or thumb rest (see figures 3 and 4) in the longitudinal direction of the pistol are permitted.
- viii) A weight with a rubber or rubber knife-edge or a round configuration with rubber must be used. A roller on the trigger weight is not permitted. A dead weight must be used with no springs or other devices.



The weight of the trigger pull must be measured, with the test weight suspended near the middle of the trigger (see Figure 5) and the barrel held vertically. The weight must be placed on a horizontal surface and lifted clear of the surface. The tests must be conducted by the equipment control officials. The minimum weight of the trigger pull must be maintained throughout the competition. A maximum of three (3) attempts to lift the weight is allowed. If it does not pass it may only be re submitted after adjustment. The propellant gas/air must be discharged.

### 5.8.2 Laser Pistol

- i) Only single shot pistol is allowed without any form of magazine or clip. The shot must be activated by a mechanical trigger.
- ii) The weight of the pistol with all accessories must not exceed 1500 grams. There must be capability of vertical and horizontal aiming correction. The minimum weight is 800 grams (tolerance 5%), for Under 17 (YB) Youth competitions 500 grams (tolerance 5%).
- iii) The overall size of the pistol is limited to dimensions which permit it to be enclosed completely in a rectangular box with inside dimensions of 420mm x 200mm x 50mm. A manufacturing tolerance of + 1.0mm in the dimensions of the box is permitted. The minimum overall size is 20% of the above dimensions (336mm x 160mm x 40mm) with the same tolerance.
- iv) Only open sights are allowed. Optical, mirror, telescope, laser-beam, electronically projected dot sights etc. are prohibited. Any aiming device programmed to activate the firing mechanism is prohibited. No protective covering is permitted on front or rear sights.
- v) No part of the grip or accessories may encircle the hand. The heel rest must extend at an angle not less than 90° to the grip. Any upward curvature of the heel and/or thumb rests and/or downward curvature of the side opposite the thumb is prohibited (see figure 2). The thumb support must allow the free upward vertical movement of the thumb. However, curved surfaces on the grips or frame, including the heel and/or thumb rest (see figures 3 and 4) in the longitudinal direction of the pistol are permitted.
- vi) The laser cartridge/module must be accompanied by a state certificate of the product as such and a certificate issued by the producer together with serial numbers. UIPM will provide a model for the producers' certificate. This certificate confirms to the UIPM compliance of the installed laser module with the EN 60825:2007/IEC 60825 (and all updates) concerning the classification as to laser class 2
- vii) The laser cartridge must carry the UIPM laser signal of 15,6ms laser signal duration, red colour (635 - 650nm). Pistols already in use in 2013 may continue to use the UIPM laser signal of 25,2ms..
- viii) The following items will be tested at three selected competitions per season (unannounced tests) by the Equipment Control Section:
  - a) The used Laser modules comply with Laser class 2 (EN 60825:2007/IEC 60825, and all updates).
  - b) Laser pulse to generate is from 635 to 650nm wavelength +/- 5nm;
  - c) The parameter of the embedded UIPM Laser signal, signal duration of 15,6 ms (for pistols in use 2013 25,2ms).
  - d) Beam diameter: 6mm\_+ 0,5 mm at 10 m distance.
  - e) The time the laser beam is released from the pistol, after pushing the trigger, must be between 6ms and 10ms;
  - f) Wire and radio free;
  - g) After approval for the competition the change of any setting for that competition period is blocked.

## **PART C EQUIPMENT AND FACILITIES PROVIDED BY THE LOC**

### **5.9 The Field of Play**

#### **5.9.1 The Venue**

- i) The combined event venue is the site on which the combined event competition is conducted, and consists of the combined event shooting range and the running course. The LOC is responsible for providing a safe and acceptable Combined Event Course.
- ii) The venue must be technically suitable, according to these rules, to allow all the types of combined event competition to be held. It must offer the best possible viewing of the



competitions to spectators, and fulfil all the requirements of TV coverage taking into account protection against sunlight as specified below under Article 5.9.4.i)..

#### 5.9.2 The Different Areas

- i) There must be the start/finish area, shooting range, last penalties stop area, relay hand-over zone, running course 800m (600m, 400m) lap, judges area, coaches area, media and photographers area, spectator areas, as well as buildings and offices necessary for the UIPM and LOC.
- ii) All the areas and most of the running course shall be located on level ground and close together, so as to provide good viewing of competition for the majority of the spectators but without permitting the spectators to access the restricted areas.
- iii) These areas and critical parts of the course must be fenced off in order to prevent pentathletes from being impeded or going off course and to prevent access by unauthorised persons. However, the height and extent of the fencing must be minimised as much as possible to avoid interference to TV coverage.
- iv) There must be sufficient space for pentathletes and competition officials to conduct their required activities and adequate room for team support staff, media, photographers and spectators, and enough space for TV camera crews and their broadcasting facilities without the broadcasting interfering with the competition.
- v) A sheltered area for the pentathletes must be provided by the LOC to protect them from the weather.
- vi) Zones for TV coverage of the competitions will be established on the course, in consultation with the LOC, the UIPM TD/NTO and TV advisor responsible for the event. The primary purpose of the zones shall be to ensure the best possible coverage of the competition and in particular to prevent obstruction of the TV image by non-competing persons.
- vii) Adjacent to the finish zone, a fenced-off area (Mixed Zone) has to be established for TV company representatives, media and photographers to have close contact with the competitors for interviews and pictures after they finish.
- viii) An exclusive seating area for VIPs and Sponsors must be located by the LOC in the place most appropriate for optimal viewing of the event.
- ix) It is recommended that the LOC provides a separate area close to the Shooting Range with 5 – 6 targets for the athletes.

#### 5.9.3 The Running Course

- i) The course must be clearly marked and defined so that a pentathlete is at no time in doubt how to follow the course. The course can be laid out on any kind of surface or surfaces. It must be designed so that there is a minimum risk of injury to the pentathletes without therefore no sharp turns or steep declines.
- ii) The maximum climb of the course is 50 metres.
- iii) The total climb is measured from perpendicular angle from the start area and adding together the total metres of climb from each level.
- iv) The last 50 metres of the course shall be straight and flat and the part of the course from the start line to the shooting place must be large enough to facilitate the start and the approach of the shooting positions.
- v) The course must be marked with a signpost at 400 metres.
- vi) The total course must be wide enough to permit two runners to pass each other at any point on the course.
- vii) The start and finish line must always be in the same area.
- viii) The course must be clearly marked with flags, tape and/or marks on the ground so that the direction of the course is always visible for the pentathletes. All angles on the courses in competitions category “A” and “B” have to be marked by a clearly visible tape 0.5-1m above the ground, 10m before and 10m after the corner. It is the obligation of the UIPM TD/NTO to check the course. At UIPM World Championships the course has to be marked by a clearly visible tape 0.5–0.7m above the ground on both sides of the course.
- ix) The start line and the finish line must be marked by a white line at least 5cm wide on the ground at the place of the start and the finish. It is recommended that a gantry (arch, gate, etc.), vertical poles or something similar also mark the start line and the finish line.
- x) In the Relay competition the start line and the finish line must be a minimum 5m wide. 10m on each side of the finish line must be set for a hand-over zone of 20m length.



Thus the dimension of the zone will be 20m x minimum 5m. This zone must be clearly marked by demarcation lines.

- xi) The finish area behind the finish line must be large enough to permit the LOC to take care of the pentathletes having completed the course.
- xii) Access to the finish area with the timing device and timekeepers must be suitably restricted so as not to allow access by pentathletes, media or spectators. Particular attention must be paid to the running shooting zone, to avoid collision between the pentathletes entering the running course after the shooting phase.
- xiii) At all official UIPM Category "A" and "B" competitions a UIPM TD/NTO must inspect and validate the length and path of the course and make changes if necessary. At Olympic Games and World Championships, this inspection must take place at least two days before the start of the competition, in all other competitions, at least one day before the start of the competition.
- xiv) At least 30 minutes before the start, the course must be marked so it is possible to start the warming up.
- xv) At least 5 minutes before the start all necessary restrictions must be settled.

#### 5.9.4 Shooting Range Requirements

- i) The range can be indoor or outdoor and must be constructed so that direct sun does not disturb the pentathletes. The targets should be positioned so that the sun does not interfere directly with the registering of shots on the targets.
- ii) If the venue, the running course and the targets are sufficiently illuminated the Combined Event can be organized at night. (Picture 1)
- iii) The shooting range must be built in such a way it can guarantee the safety of the pentathletes, coaches, judges and spectators. The firing distance is 10 metres, measured from the firing lane to the target face.  $\pm 0,05\text{m}$  is accepted as tolerance.
- iv) With pellet pistols the shooting range must be equipped with lateral walls covering the tops shooting positions. With laser pistols no lateral walls are required but access to the range by unapproved people must be in place.
- v) With pellet pistols the background area behind the targets must be non-reflecting, medium, neutral colour. With laser pistols no back wall is needed but access to the range by unapproved people must be in place.
- vi) If the weather forecast is predicted as bad the shooting range must protect the pentathletes from the rain using special roof coverage and a waterproof box to protect the pistols, water, towels and binoculars of the pentathletes located under the shooting table.
- vii) The shooting range must be prepared in such a way the spectators can enjoy the competition and watch the finish, so with the finish line near the shooting range.
- viii) During training, warm up and competition, competitors must enter the range from one side and exit the other side.
- ix) The shooting station must be marked with numbers of a minimum height 12cm, corresponding to the firing point number. Shooting station nr 1 must be the farthest away from the starting gates.
- x) The pentathlete shooting area (minimum 1m and maximum 2m wide x 1.5m deep minimum) must be clearly defined with visible ground painted lateral lines and back line (start line for each running leg). Paint of lateral lines can be replaced by tape or small advertising banner.
- xi) There must be sufficient space (minimum 4m) behind the firing points to allow the pentathletes, before and after each shooting series, to run to their shooting station without disturbing the other pentathletes and to permit the Range Officials and the UIPM TDs/NTOs to perform their duties.
- xii) Targets must be marked with numbers corresponding to their shooting station number. The numbers must have a minimum height of 25cm to be easily seen under normal shooting conditions with normal vision from the appropriate shooting station and from VIP area, public seats and TV cameras.
- xiii) The LOC must guarantee provision of 2 reserve spare targets, numbered S1 and S2. In case of insufficient number of targets for all the pentathletes, the combined event can be organised in two or more series with the top pentathletes competing in the last series.
- xiv) The targets and all the other equipments (target numbers, results displays, target covers, lights) must be fixed in such a manner that they have no appreciable movement.



- xv) The height of the target centre must be within the following height measured from level of the floor of the firing point:
  - a) Standard Height Variation: 1,40m +/- 0,05 m
  - b) Horizontal variation: 0,25 m.
- xvi) The firing point must be equipped with:
  - a) a table or bench, about 0,7m – 0,8m high. With laser pistol in the tabletop there should be a soft foam cushion provided by LOC ( $\pm$  A4 size, 8cm height recommended) to avoid disturbances on the system;
  - b) the table must have a protection for the pistol and the pellets in case of rain (waterproof box) or a place under the table;
  - c) With LPT the shooting position must be equipped with a transparent tabletop or with a waterproof transparent plastic box to protect the feedback device.
- xvii) Athletes shall maintain a tidy shooting position with only essential equipment on the table.
- xviii) With Electronic and Laser targets an adequate uninterrupted power backup system allowing a minimum of 15 m run of the system must be provided by LOC in case stadium/arena is not already equipped. The power cable must be 3\*2.5mm 2 section with a waterproof box equipped with a 20A security. This box has to be fixed on the back side of the wall at 2m height.

## 5.10 OTHER EQUIPMENT

### 5.10.1 Target Requirements

- i) In UIPM Senior A Category competitions laser precision targets are mandatory.
- ii) Only targets homologated by UIPM can be used at Category “A” and “B” competitions and PWR competitions.
- iii) All targets used at Senior Category A competitions must be able to provide a live data stream compliant with UIPM data shooting protocol.
- iv) All target models, except LPT, must be able to be used without any computer connection required.
- v) The colour of the target centre zone is black. The dimension of this area (Figure 11) is 59.5mm, with a tolerance of 0.5mm. Target surface must be white and of a non reflecting material so that the black aiming area (centre) is clearly visible under normal light conditions at the appropriate distances. The targets must work in all weather conditions including rain and direct sunlight.
- vi) With pellet targets only shots that are completely inside the 59.5mm valid zone (with the full perimeter) can be physically registered as “hit”.
- vii) With laser hit targets, a shot that hits the black centre zone is a valid shot (A minimum of 80% of the signal duration has to be detected).
- viii) With laser precision targets a shot is valid if, after the automatic reconstruction of the calibre 4.5mm from the beam centre impact, hits 7.3 or more.

### 5.10.2 Mechanical target (MT) (see Figure 6):

- i) Mechanical falling targets consist of 5 black holes.
- ii) The basic mechanical target is: Length 42cm. Height 15cm Width 15cm.
- iii) The minimum distance between each hole is 8cm.
- iv) For correct functioning of the mechanical target, it is absolutely necessary to adjust the target with a spirit or other level (as if not exactly level the target could malfunction and generate irregular shooting results).
- v) The reset rope must be brought in a straight line to the pentathlete’s shooting table and fixed there for ease of use.
- vi) The white plastic surface must not be painted. The surface of the matrix may be painted.

### 5.10.3 Electronic Pellet Target (ET) (see Figure 7)

- i) Electronic target consists of one black single aim. Connected to it is a 5 green/red lamp device to show results.
- ii) The Shooting zone - for competition, target (shooting zone) and indicators - must be separated.
- iii) Target standard dimension: Minimum visible size of target card 170 mm x 170 mm.



- iv) Targets have to be fixed to a rack or wall (height 2.3m approx). If the wall is not wood or plastic, a structure or materials suitable to receive a screw of 6mm diameter must be prepared for each station at 1.30m and 2.10m height.
- v) The shooting time starts when the target is hit by the first shot (valid or not).
- vi) ET input power must be in the range 90-240 AV. This box has to be fixed on the back side of the wall at 2 m height. A power system (minimum 750VA) must be provided by the LOC in case stadium/arena is not already equipped. Output power has to be less than 24V.
- vii) ET must be usable under all weather conditions, including sunny weather.

#### 5.10.4 Laser "HIT" Target (HT) (see figure 8)

In this type of target only the black zone 59,5mm (tolerance  $\pm 0,5$ mm) is a sensitive area. The technical requirements for this target are:

- i) Laser signal is to decode from 635 to 650nm wavelength +/- 5nm;
- ii) UIPM Laser signal has to be embedded and is fixed at 15.6 ms (for equipment in use 2013: 25,2ms);
- iii) Interference from any non-visible light has to be avoided and must be blocked by an IR-filter;
- iv) The target must detect hits precisely, from all kinds of Laser containers with UIPM signal with the following characteristics;
- v) Input maximum 12V and maximum 1000 mA;
- vi) Front target side minimum 170mm \* 170mm;
- vii) 0,5mm precision (concerns shots evaluated between valid and miss zones);
- viii) 100ms reaction time max; hit indication at the Indicators with 400ms delay-time in respect to the Computer Interface at the same time;
- ix) Interface to external lights;

#### 5.10.5 Laser Precision Targets (LPT) (see figure 9)

Mandatory in Senior A Category competitions.

- i) The technical requirements are:
  - a) Max input 24V;
  - b) 20ms reaction time max;
  - c) compliant with ISSF 10m target pistol draw;
  - d) timing and data independent from lights units.
- ii) Specific requirements to all level competitions:
  - a) Live display of shot possible on screen in 1/10 of ISSF units;
  - b) 0,5mm precision laser dot detection (it concerns the whole target);
  - c) able to send data of shots (X&Y Position of shot in 0,5mm units from centre compliance to UIPM data protocol);
  - d) able to be used outdoor;
  - e) connection to external lights;
  - f) external perturbation protected (external laser beam not coming from one athlete);
  - g) competition mode must block all possible settings (including access to operating system if any) and follow strictly UIPM competition rules.
- iii) The dimensions of all scoring rings are measured from the outside edges (outside diameter) of the scoring rings (see figure 11).

#### 5.10.6 Indicators (Result Display Lights) (see Figure 10)

- i) Indicator Wavelength: Red colour must be 660nm and green colour 525nm. (+/- 5nm.) Indicators must be installed minimum 0,80cm up to the top of the target.
- ii) For "A" Category competitions, indicators must be 55mm diameter with minimum of 140° viewing angle.
- iii) For all other competitions, 55mm diameter or 26mm diameter with minimum 90° viewing angle. Background of the indicators must be a contrasting colour. Distance between each red/green lamp must be 40mm.
- (iii) Indicators can be placed horizontally or vertically.

#### 5.10.7 Boxes

The LOC must provide boxes in the Shooting Range per station for athletes' use. These boxes are to be removed from the Shooting Range at the start and stored in a safe place until after competition.





## **5.11 LOC CONTROL DEVICES AND TOOLS**

### **5.11.1 Control Material**

Clothing control is made by observation, using a ruler if necessary.

For the control of all kind of pistols (Part B, Art. 5.8) the LOC must have: box for dimensions, scale for the weight, trigger weight device, ruler, square, angle scale and a system to register and mark the approved pistols.

For the laser pistols and containers the LOC must also have instruments to check the laser beam - power, diameter and time - and the power of the battery.

### **5.11.2 Built Material and Tools**

The LOC must have available material and tools to build, maintain and rebuild the FOP as described in Part B (5.9 The FOP and 5.10 – Other Equipment). This includes measuring tapes, rulers, measuring wheels, hammers, tools and equipment to repair the ground, barriers, poles or posts, tape, ink, paintbrush, plastic cones, and so on.

### **5.11.3 Laser Pistol Tests**

The UIPM will provide the relevant test equipment and advise the LOCs of the three selected events per season. Such pistol tests will be organised one day before the start of competition, separately for each gender.



**PENALTY TABLE**

**COMBINED EVENT**

**Appendix 5A**

OFFENCES	Rule	Penalty		
		1st time	Subsequent	Paid at *
Contravening clothing regulations	5.6.1 i	10"		PG
Modifying dimensions of start numbers	5.6.1 ii	10"		PG
False start	5.6.1 iii	10"		SL
Not placing a pistol safely on the table after warm up or shooting series	5.6.1 iv	10"	10"	SL or LPA
Not loading each shot with the pistol in contact with the shooting table	5.6.1 v	10"	10"	SL or LPA
Coach assistance during warm up outside the designated coaches area	5.6.1.vi	Warning	10"	PG
Not having the pistol in the box before the official warm up period has started	5.6.1 vii	Warning	10"	PG
Starting running before the shooting time has expired without having successfully completed the shooting series ("5 green lights")	5.6.1 viii	10"	10"	SL or LPA
Not completing the course	5.6.2 i	Elimination		
Deviation, deliberate or not, from the course	5.6.2 ii	Elimination		
Unauthorised assistance	5.6.2 iii	Elimination		
Using a non-approved pistol	5.6.2 iv	Elimination		
Shooting on a wrong target	5.6.2 v	Elimination		
Not stopping at the last penalty area when instructed by an official	5.6.2 vi	Elimination		
Using constant beam during the competition series and or audio communication outside of preparation and warm up time.	5.6.2 vii	Elimination		
Modifying or adjusting the approved pistol	5.6.3 i	Disqualification		
Exchanging for a non approved pistol	5.6.3 ii	Disqualification		
Blatant attempt to start too early	5.6.3 iii	Disqualification		
Jostling, running across, or obstructing another athlete	5.6.3 iv	Disqualification		

\* - Penalty Start Gate – PG; Shooting Line – SL; Last Penalty Area - LPA

The penalties for the offences of 5.6.1 iv and viii, if committed in the 3<sup>rd</sup> shooting series, will be paid in the Last penalty Area.



**POINTS TABLE**

**COMBINED EVENT**

**Appendix 5B1**

**Individual: Seniors, Juniors, Under 19 (YA)**

**Relay: Seniors, Juniors, Under 19 (YA), Under 17 (YB)**

<b>time</b>	<b>pts</b>	<b>Time</b>	<b>pts</b>	<b>time</b>	<b>pts</b>	<b>time</b>	<b>pts</b>	<b>time</b>	<b>pts</b>	<b>time</b>	<b>Pts</b>
10:00	700	10:40	660	11:20	620	12:00	580	12:40	540	<b>13:20</b>	<b>500</b>
10:01	699	10:41	659	11:21	619	12:01	579	12:41	539	13:21	499
10:02	698	10:42	658	11:22	618	12:02	578	12:42	538	13:22	498
10:03	697	10:43	657	11:23	617	12:03	577	12:43	537	13:23	497
10:04	696	10:44	656	11:24	616	12:04	576	12:44	536	13:24	496
10:05	695	10:45	655	11:25	615	12:05	575	12:45	535	13:25	495
10:06	694	10:46	654	11:26	614	12:06	574	12:46	534	13:26	494
10:07	693	10:47	653	11:27	613	12:07	573	12:47	533	13:27	493
10:08	692	10:48	652	11:28	612	12:08	572	12:48	532	13:28	492
10:09	691	10:49	651	11:29	611	12:09	571	12:49	531	13:29	491
<u>10:10</u>	690	<u>10:50</u>	650	<u>11:30</u>	610	<u>12:10</u>	570	<u>12:50</u>	530	<u>13:30</u>	490
10:11	689	10:51	649	11:31	609	12:11	569	12:51	529	13:31	489
10:12	688	10:52	648	11:32	608	12:12	568	12:52	528	13:32	488
10:13	687	10:53	647	11:33	607	12:13	567	12:53	527	13:33	487
10:14	686	10:54	646	11:34	606	12:14	566	12:54	526	13:34	486
10:15	685	10:55	645	11:35	605	12:15	565	12:55	525	13:35	485
10:16	684	10:56	644	11:36	604	12:16	564	12:56	524	13:36	484
10:17	683	10:57	643	11:37	603	12:17	563	12:57	523	13:37	483
10:18	682	10:58	642	11:38	602	12:18	562	12:58	522	13:38	482
10:19	681	10:59	641	11:39	601	12:19	561	12:59	521	13:39	481
<u>10:20</u>	680	<u>11:00</u>	640	<u>11:40</u>	600	<u>12:20</u>	560	<u>13:00</u>	520	<u>13:40</u>	480
10:21	679	11:01	639	11:41	599	12:21	559	13:01	519	13:41	479
10:22	678	11:02	638	11:42	598	12:22	558	13:02	518	13:42	478
10:23	677	11:03	637	11:43	597	12:23	557	13:03	517	13:43	477
10:24	676	11:04	636	11:44	596	12:24	556	13:04	516	13:44	476
10:25	675	11:05	635	11:45	595	12:25	555	13:05	515	13:45	475
10:26	674	11:06	634	11:46	594	12:26	554	13:06	514	13:46	474
10:27	673	11:07	633	11:47	593	12:27	553	13:07	513	13:47	473
10:28	672	11:08	632	11:48	592	12:28	552	13:08	512	13:48	472
10:29	671	11:09	631	11:49	591	12:29	551	13:09	511	13:49	471
<u>10:30</u>	670	<u>11:10</u>	630	<u>11:50</u>	590	<u>12:30</u>	550	<u>13:10</u>	510	<u>13:50</u>	470
10:31	669	11:11	629	11:51	589	12:31	549	13:11	509	13:51	469
10:32	668	11:12	628	11:52	588	12:32	548	13:12	508	13:52	468
10:33	667	11:13	627	11:53	587	12:33	547	13:13	507	13:53	467
10:34	666	11:14	626	11:54	586	12:34	546	13:14	506	13:54	466
10:35	665	11:15	625	11:55	585	12:35	545	13:15	505	13:55	465
10:36	664	11:16	624	11:56	584	12:36	544	13:16	504	13:56	464
10:37	663	11:17	623	11:57	583	12:37	543	13:17	503	13:57	463
10:38	662	11:18	622	11:58	582	12:38	542	13:18	502	13:58	462
10:39	661	11:19	621	11:59	581	12:39	541	13:19	501	13:59	461



min	pts	Min	pts	min	pts	min	pts	min	pts	min	Pts
14:00	460	14:40	420	15:20	380	16:00	340	16:40	300	17:20	260
14:01	459	14:41	419	15:21	379	16:01	339	16:41	299	17:21	259
14:02	458	14:42	418	15:22	378	16:02	338	16:42	298	17:22	258
14:03	457	14:43	417	15:23	377	16:03	337	16:43	297	17:23	257
14:04	456	14:44	416	15:24	376	16:04	336	16:44	296	17:24	256
14:05	455	14:45	415	15:25	375	16:05	335	16:45	295	17:25	255
14:06	454	14:46	414	15:26	374	16:06	334	16:46	294	17:26	254
14:07	453	14:47	413	15:27	373	16:07	333	16:47	293	17:27	253
14:08	452	14:48	412	15:28	372	16:08	332	16:48	292	17:28	252
14:09	451	14:49	411	15:29	371	16:09	331	16:49	291	17:29	251
<u>14:10</u>	450	<u>14:50</u>	410	<u>15:30</u>	370	<u>16:10</u>	330	<u>16:50</u>	290	<u>17:30</u>	250
14:11	449	14:51	409	15:31	369	16:11	329	16:51	289	17:31	249
14:12	448	14:52	408	15:32	368	16:12	328	16:52	288	17:32	248
14:13	447	14:53	407	15:33	367	16:13	327	16:53	287	17:33	247
14:14	446	14:54	406	15:34	366	16:14	326	16:54	286	17:34	246
14:15	445	14:55	405	15:35	365	16:15	325	16:55	285	17:35	245
14:16	444	14:56	404	15:36	364	16:16	324	16:56	284	17:36	244
14:17	443	14:57	403	15:37	363	16:17	323	16:57	283	17:37	243
14:18	442	14:58	402	15:38	362	16:18	322	16:58	282	17:38	242
14:19	441	14:59	401	15:39	361	16:19	321	16:59	281	17:39	241
<u>14:20</u>	440	<u>15:00</u>	400	<u>15:40</u>	360	<u>16:20</u>	320	<u>17:00</u>	280	<u>17:40</u>	240
14:21	439	15:01	399	15:41	359	16:21	319	17:01	279	17:41	239
14:22	438	15:02	398	15:42	358	16:22	318	17:02	278	17:42	238
14:23	437	15:03	397	15:43	357	16:23	317	17:03	277	17:43	237
14:24	436	15:04	396	15:44	356	16:24	316	17:04	276	17:44	236
14:25	435	15:05	395	15:45	355	16:25	315	17:05	275	17:45	235
14:26	434	15:06	394	15:46	354	16:26	314	17:06	274	17:46	234
14:27	433	15:07	393	15:47	353	16:27	313	17:07	273	17:47	233
14:28	432	15:08	392	15:48	352	16:28	312	17:08	272	17:48	232
14:29	431	15:09	391	15:49	351	16:29	311	17:09	271	17:49	231
<u>14:30</u>	430	<u>15:10</u>	390	<u>15:50</u>	350	<u>16:30</u>	310	<u>17:10</u>	270	<u>17:50</u>	230
14:31	429	15:11	389	15:51	349	16:31	309	17:11	269	17:51	229
14:32	428	15:12	388	15:52	348	16:32	308	17:12	268	17:52	228
14:33	427	15:13	387	15:53	347	16:33	307	17:13	267	17:53	227
14:34	426	15:14	386	15:54	346	16:34	306	17:14	266	17:54	226
14:35	425	15:15	385	15:55	345	16:35	305	17:15	265	17:55	225
14:36	424	15:16	384	15:56	344	16:36	304	17:16	264	17:56	224
14:37	423	15:17	383	15:57	343	16:37	303	17:17	263	17:57	223
14:38	422	15:18	382	15:58	342	16:38	302	17:18	262	17:58	222
14:39	421	15:19	381	15:59	341	16:39	301	17:19	261	17:59	221



<u>min</u>	<u>pts</u>	<u>Min</u>	<u>pts</u>	<u>min</u>	<u>pts</u>	<u>min</u>	<u>pts</u>	<u>min</u>	<u>pts</u>	<u>min</u>	<u>Pts</u>
<u>18:00</u>	220	<u>18:40</u>	180	<u>19:20</u>	140	<u>20:00</u>	100	<u>20:40</u>	60	<u>21:20</u>	20
18:01	219	18:41	179	19:21	139	20:01	99	20:41	59	21:21	19
18:02	218	18:42	178	19:22	138	20:02	98	20:42	58	21:22	18
18:03	217	18:43	177	19:23	137	20:03	97	20:43	57	21:23	17
18:04	216	18:44	176	19:24	136	20:04	96	20:44	56	21:24	16
18:05	215	18:45	175	19:25	135	20:05	95	20:45	55	21:25	15
18:06	214	18:46	174	19:26	134	20:06	94	20:46	54	21:26	14
18:07	213	18:47	173	19:27	133	20:07	93	20:47	53	21:27	13
18:08	212	18:48	172	19:28	132	20:08	92	20:48	52	21:28	12
18:09	211	18:49	171	19:29	131	20:09	91	20:49	51	21:29	11
<u>18:10</u>	210	<u>18:50</u>	170	<u>19:30</u>	130	<u>20:10</u>	90	<u>20:50</u>	50	<u>21:30</u>	10
18:11	209	18:51	169	19:31	129	20:11	89	20:51	49	21:31	9
18:12	208	18:52	168	19:32	128	20:12	88	20:52	48	21:32	8
18:13	207	18:53	167	19:33	127	20:13	87	20:53	47	21:33	7
18:14	206	18:54	166	19:34	126	20:14	86	20:54	46	21:34	6
18:15	205	18:55	165	19:35	125	20:15	85	20:55	45	21:35	5
18:16	204	18:56	164	19:36	124	20:16	84	20:56	44	21:36	4
18:17	203	18:57	163	19:37	123	20:17	83	20:57	43	21:37	3
18:18	202	18:58	162	19:38	122	20:18	82	20:58	42	21:38	2
18:19	201	18:59	161	19:39	121	20:19	81	20:59	41	21:39	1
<u>18:20</u>	200	<u>19:00</u>	160	<u>19:40</u>	120	<u>20:20</u>	80	<u>21:00</u>	40	<u>21:40</u>	0
18:21	199	19:01	159	19:41	119	20:21	79	21:01	39		
18:22	198	19:02	158	19:42	118	20:22	78	21:02	38		
18:23	197	19:03	157	19:43	117	20:23	77	21:03	37		
18:24	196	19:04	156	19:44	116	20:24	76	21:04	36		
18:25	195	19:05	155	19:45	115	20:25	75	21:05	35		
18:26	194	19:06	154	19:46	114	20:26	74	21:06	34		
18:27	193	19:07	153	19:47	113	20:27	73	21:07	33		
18:28	192	19:08	152	19:48	112	20:28	72	21:08	32		
18:29	191	19:09	151	19:49	111	20:29	71	21:09	31		
<u>18:30</u>	190	<u>19:10</u>	150	<u>19:50</u>	110	<u>20:30</u>	70	<u>21:10</u>	30		
18:31	189	19:11	149	19:51	109	20:31	69	21:11	29		
18:32	188	19:12	148	19:52	108	20:32	68	21:12	28		
18:33	187	19:13	147	19:53	107	20:33	67	21:13	27		
18:34	186	19:14	146	19:54	106	20:34	66	21:14	26		
18:35	185	19:15	145	19:55	105	20:35	65	21:15	25		
18:36	184	19:16	144	19:56	104	20:36	64	21:16	24		
18:37	183	19:17	143	19:57	103	20:37	63	21:17	23		
18:38	182	19:18	142	19:58	102	20:38	62	21:18	22		
18:39	181	19:19	141	19:59	101	20:39	61	21:19	21		



POINTS TABLE

COMBINED EVENT  
Individual: Under 17 (YB)

Appendix 5B2

time	pts	Time	pts	time	pts	time	pts	time	pts	time	Pts
<u>07:10</u>	700	<u>07:50</u>	660	<u>08:30</u>	620	<u>09:10</u>	580	<u>09:50</u>	540	<b>10:30</b>	<b>500</b>
07:11	699	07:51	659	08:31	619	09:11	579	09:51	539	10:31	499
07:12	698	07:52	658	08:32	618	09:12	578	09:52	538	10:32	498
07:13	697	07:53	657	08:33	617	09:13	577	09:53	537	10:33	497
07:14	696	07:54	656	08:34	616	09:14	576	09:54	536	10:34	496
07:15	695	07:55	655	08:35	615	09:15	575	09:55	535	10:35	495
07:16	694	07:56	654	08:36	614	09:16	574	09:56	534	10:36	494
07:17	693	07:57	653	08:37	613	09:17	573	09:57	533	10:37	493
07:18	692	07:58	652	08:38	612	09:18	572	09:58	532	10:38	492
07:19	691	07:59	651	08:39	611	09:19	571	09:59	531	10:39	491
<u>07:20</u>	690	<u>08:00</u>	650	<u>08:40</u>	610	<u>09:20</u>	570	<u>10:00</u>	530	<u>10:40</u>	490
07:21	689	08:01	649	08:41	609	09:21	569	10:01	529	10:41	489
07:22	688	08:02	648	08:42	608	09:22	568	10:02	528	10:42	488
07:23	687	08:03	647	08:43	607	09:23	567	10:03	527	10:43	487
07:24	686	08:04	646	08:44	606	09:24	566	10:04	526	10:44	486
07:25	685	08:05	645	08:45	605	09:25	565	10:05	525	10:45	485
07:26	684	08:06	644	08:46	604	09:26	564	10:06	524	10:46	484
07:27	683	08:07	643	08:47	603	09:27	563	10:07	523	10:47	483
07:28	682	08:08	642	08:48	602	09:28	562	10:08	522	10:48	482
07:29	681	08:09	641	08:49	601	09:29	561	10:09	521	10:49	481
<u>07:30</u>	680	<u>08:10</u>	640	<u>08:50</u>	600	<u>09:30</u>	560	<u>10:10</u>	520	<u>10:50</u>	480
07:31	679	08:11	639	08:51	599	09:31	559	10:11	519	10:51	479
07:32	678	08:12	638	08:52	598	09:32	558	10:12	518	10:52	478
07:33	677	08:13	637	08:53	597	09:33	557	10:13	517	10:53	477
07:34	676	08:14	636	08:54	596	09:34	556	10:14	516	10:54	476
07:35	675	08:15	635	08:55	595	09:35	555	10:15	515	10:55	475
07:36	674	08:16	634	08:56	594	09:36	554	10:16	514	10:56	474
07:37	673	08:17	633	08:57	593	09:37	553	10:17	513	10:57	473
07:38	672	08:18	632	08:58	592	09:38	552	10:18	512	10:58	472
07:39	671	08:19	631	08:59	591	09:39	551	10:19	511	10:59	471
<u>07:40</u>	670	<u>08:20</u>	630	<u>09:00</u>	590	<u>09:40</u>	550	<u>10:20</u>	510	<u>11:00</u>	470
07:41	669	08:21	629	09:01	589	09:41	549	10:21	509	11:01	469
07:42	668	08:22	628	09:02	588	09:42	548	10:22	508	11:02	468
07:43	667	08:23	627	09:03	587	09:43	547	10:23	507	11:03	467
07:44	666	08:24	626	09:04	586	09:44	546	10:24	506	11:04	466
07:45	665	08:25	625	09:05	585	09:45	545	10:25	505	11:05	465
07:46	664	08:26	624	09:06	584	09:46	544	10:26	504	11:06	464
07:47	663	08:27	623	09:07	583	09:47	543	10:27	503	11:07	463
07:48	662	08:28	622	09:08	582	09:48	542	10:28	502	11:08	462
07:49	661	08:29	621	09:09	581	09:49	541	10:29	501	11:09	461



time	pts	Time	pts	time	pts	time	pts	time	pts	time	pts
11:10	460	11:50	420	12:30	380	13:10	340	13:50	300	14:30	260
11:11	459	11:51	419	12:31	379	13:11	339	13:51	299	14:31	259
11:12	458	11:52	418	12:32	378	13:12	338	13:52	298	14:32	258
11:13	457	11:53	417	12:33	377	13:13	337	13:53	297	14:33	257
11:14	456	11:54	416	12:34	376	13:14	336	13:54	296	14:34	256
11:15	455	11:55	415	12:35	375	13:15	335	13:55	295	14:35	255
11:16	454	11:56	414	12:36	374	13:16	334	13:56	294	14:36	254
11:17	453	11:57	413	12:37	373	13:17	333	13:57	293	14:37	253
11:18	452	11:58	412	12:38	372	13:18	332	13:58	292	14:38	252
11:19	451	11:59	411	12:39	371	13:19	331	13:59	291	14:39	251
11:20	450	12:00	410	12:40	370	13:20	330	14:00	290	14:40	250
11:21	449	12:01	409	12:41	369	13:21	329	14:01	289	14:41	249
11:22	448	12:02	408	12:42	368	13:22	328	14:02	288	14:42	248
11:23	447	12:03	407	12:43	367	13:23	327	14:03	287	14:43	247
11:24	446	12:04	406	12:44	366	13:24	326	14:04	286	14:44	246
11:25	445	12:05	405	12:45	365	13:25	325	14:05	285	14:45	245
11:26	444	12:06	404	12:46	364	13:26	324	14:06	284	14:46	244
11:27	443	12:07	403	12:47	363	13:27	323	14:07	283	14:47	243
11:28	442	12:08	402	12:48	362	13:28	322	14:08	282	14:48	242
11:29	441	12:09	401	12:49	361	13:29	321	14:09	281	14:49	241
11:30	440	12:10	400	12:50	360	13:30	320	14:10	280	14:50	240
11:31	439	12:11	399	12:51	359	13:31	319	14:11	279	14:51	239
11:32	438	12:12	398	12:52	358	13:32	318	14:12	278	14:52	238
11:33	437	12:13	397	12:53	357	13:33	317	14:13	277	14:53	237
11:34	436	12:14	396	12:54	356	13:34	316	14:14	276	14:54	236
11:35	435	12:15	395	12:55	355	13:35	315	14:15	275	14:55	235
11:36	434	12:16	394	12:56	354	13:36	314	14:16	274	14:56	234
11:37	433	12:17	393	12:57	353	13:37	313	14:17	273	14:57	233
11:38	432	12:18	392	12:58	352	13:38	312	14:18	272	14:58	232
11:39	431	12:19	391	12:59	351	13:39	311	14:19	271	14:59	231
11:40	430	12:20	390	13:00	350	13:40	310	14:20	270	15:00	230
11:41	429	12:21	389	13:01	349	13:41	309	14:21	269	15:01	229
11:42	428	12:22	388	13:02	348	13:42	308	14:22	268	15:02	228
11:43	427	12:23	387	13:03	347	13:43	307	14:23	267	15:03	227
11:44	426	12:24	386	13:04	346	13:44	306	14:24	266	15:04	226
11:45	425	12:25	385	13:05	345	13:45	305	14:25	265	15:05	225
11:46	424	12:26	384	13:06	344	13:46	304	14:26	264	15:06	224
11:47	423	12:27	383	13:07	343	13:47	303	14:27	263	15:07	223
11:48	422	12:28	382	13:08	342	13:48	302	14:28	262	15:08	222
11:49	421	12:29	381	13:09	341	13:49	301	14:29	261	15:09	221



time	pts	Time	pts	time	pts	time	pts	time	pts	time	pts
15:10	220	15:50	180	16:30	140	17:10	100	17:50	60	18:30	20
15:11	219	15:51	179	16:31	139	17:11	99	17:51	59	18:31	19
15:12	218	15:52	178	16:32	138	17:12	98	17:52	58	18:32	18
15:13	217	15:53	177	16:33	137	17:13	97	17:53	57	18:33	17
15:14	216	15:54	176	16:34	136	17:14	96	17:54	56	18:34	16
15:15	215	15:55	175	16:35	135	17:15	95	17:55	55	18:35	15
15:16	214	15:56	174	16:36	134	17:16	94	17:56	54	18:36	14
15:17	213	15:57	173	16:37	133	17:17	93	17:57	53	18:37	13
15:18	212	15:58	172	16:38	132	17:18	92	17:58	52	18:38	12
15:19	211	15:59	171	16:39	131	17:19	91	17:59	51	18:39	11
<u>15:20</u>	210	<u>16:00</u>	170	<u>16:40</u>	130	<u>17:20</u>	90	<u>18:00</u>	50	<u>18:40</u>	10
15:21	209	16:01	169	16:41	129	17:21	89	18:01	49	18:41	9
15:22	208	16:02	168	16:42	128	17:22	88	18:02	48	18:42	8
15:23	207	16:03	167	16:43	127	17:23	87	18:03	47	18:43	7
15:24	206	16:04	166	16:44	126	17:24	86	18:04	46	18:44	6
15:25	205	16:05	165	16:45	125	17:25	85	18:05	45	18:45	5
15:26	204	16:06	164	16:46	124	17:26	84	18:06	44	18:46	4
15:27	203	16:07	163	16:47	123	17:27	83	18:07	43	18:47	3
15:28	202	16:08	162	16:48	122	17:28	82	18:08	42	18:48	2
15:29	201	16:09	161	16:49	121	17:29	81	18:09	41	18:49	1
<u>15:30</u>	200	<u>16:10</u>	160	<u>16:50</u>	120	<u>17:30</u>	80	<u>18:10</u>	40	<u>18:50</u>	0
15:31	199	16:11	159	16:51	119	17:31	79	18:11	39		
15:32	198	16:12	158	16:52	118	17:32	78	18:12	38		
15:33	197	16:13	157	16:53	117	17:33	77	18:13	37		
15:34	196	16:14	156	16:54	116	17:34	76	18:14	36		
15:35	195	16:15	155	16:55	115	17:35	75	18:15	35		
15:36	194	16:16	154	16:56	114	17:36	74	18:16	34		
15:37	193	16:17	153	16:57	113	17:37	73	18:17	33		
15:38	192	16:18	152	16:58	112	17:38	72	18:18	32		
15:39	191	16:19	151	16:59	111	17:39	71	18:19	31		
<u>15:40</u>	190	<u>16:20</u>	150	<u>17:00</u>	110	<u>17:40</u>	70	<u>18:20</u>	30		
15:41	189	16:21	149	17:01	109	17:41	69	18:21	29		
15:42	188	16:22	148	17:02	108	17:42	68	18:22	28		
15:43	187	16:23	147	17:03	107	17:43	67	18:23	27		
15:44	186	16:24	146	17:04	106	17:44	66	18:24	26		
15:45	185	16:25	145	17:05	105	17:45	65	18:25	25		
15:46	184	16:26	144	17:06	104	17:46	64	18:26	24		
15:47	183	16:27	143	17:07	103	17:47	63	18:27	23		
15:48	182	16:28	142	17:08	102	17:48	62	18:28	22		
15:49	181	16:29	141	17:09	101	17:49	61	18:29	21		





**POINTS TABLE**

**COMBINED EVENT**

**Appendix 5B3**

**Individual Boys & Girls: Under 15 (YC)**

**Relay: Under 15 (YC)**

<b>time</b>	<b>pts</b>	<b>Time</b>	<b>Pts</b>	<b>time</b>	<b>pts</b>	<b>time</b>	<b>pts</b>	<b>Time</b>	<b>pts</b>	<b>time</b>	<b>pts</b>
04:20	700	05:00	660	05:40	620	06:20	580	07:00	540	<b>07:40</b>	<b>500</b>
04:21	699	05:01	659	04:41	619	06:21	579	07:01	539	07:41	499
04:22	698	05:02	658	05:42	618	06:22	578	07:02	538	07:42	498
04:23	697	05:03	657	05:43	617	06:23	577	07:03	537	07:43	497
04:24	696	05:04	656	05:44	616	06:24	576	07:04	536	07:44	496
04:25	695	05:05	655	04:45	615	06:25	575	07:05	535	07:45	495
04:26	694	05:06	654	05:46	614	06:26	574	07:06	534	07:46	494
04:27	693	05:07	653	05:47	613	06:27	573	07:07	533	07:47	493
04:28	692	05:08	652	04:48	612	06:28	572	07:08	532	07:48	492
04:29	691	05:09	651	05:49	611	06:29	571	07:09	531	07:49	491
<u>04:30</u>	690	<u>05:10</u>	650	<u>05:50</u>	610	<u>06:30</u>	570	<u>07:10</u>	530	<u>07:50</u>	490
04:31	689	05:11	649	05:51	609	06:31	569	07:11	529	07:51	489
04:32	688	05:12	648	05:52	608	06:32	568	07:12	528	07:52	488
04:33	687	05:13	647	04:53	607	06:33	567	07:13	527	07:53	487
04:34	686	05:14	646	05:54	606	06:34	566	07:14	526	07:54	486
04:35	685	05:15	645	05:55	605	06:35	565	07:15	525	07:55	485
04:36	684	05:16	644	05:56	604	06:36	564	07:16	524	07:56	484
04:37	683	05:17	643	04:57	603	06:37	563	07:17	523	07:57	483
04:38	682	05:18	642	05:58	602	06:38	562	07:18	522	07:58	482
04:39	681	05:19	641	05:59	601	06:39	561	07:19	521	07:59	481
<u>04:40</u>	680	<u>05:20</u>	640	<u>06:00</u>	600	<u>06:40</u>	560	<u>07:20</u>	520	<u>08:00</u>	480
04:41	679	05:21	639	06:01	599	06:41	559	07:21	519	08:01	479
04:42	678	05:22	638	06:02	598	06:42	558	07:22	518	08:02	478
04:43	677	05:23	637	06:03	597	06:43	557	07:23	517	08:03	477
04:44	676	05:24	636	06:04	596	06:44	556	07:24	516	08:04	476
04:45	675	05:25	635	06:05	595	06:45	555	07:25	515	08:05	475
04:46	674	05:26	634	06:06	594	06:46	554	07:26	514	08:06	474
04:47	673	05:27	633	06:07	593	06:47	553	07:27	513	08:07	473
04:48	672	05:28	632	06:08	592	06:48	552	07:28	512	08:08	472
04:49	671	05:29	631	06:09	591	06:49	551	07:29	511	08:09	471
<u>04:50</u>	670	<u>05:30</u>	630	<u>06:10</u>	590	<u>06:50</u>	550	<u>07:30</u>	510	<u>08:10</u>	470
04:51	669	05:31	629	06:11	589	06:51	549	07:31	509	08:11	469
04:52	668	05:32	628	06:12	588	06:52	548	07:32	508	08:12	468
04:53	667	05:33	627	06:13	587	06:53	547	07:33	507	08:13	467
04:54	666	05:34	626	06:14	586	06:54	546	07:34	506	08:14	466
04:55	665	05:35	625	06:15	585	06:55	545	07:35	505	08:15	465
04:56	664	05:36	624	06:16	584	06:56	544	07:36	504	08:16	464
04:57	663	05:37	623	06:17	583	06:57	543	07:37	503	08:17	463
04:58	662	05:38	622	06:18	582	06:58	542	07:38	502	08:18	462
04:59	661	05:39	621	06:19	581	06:59	541	07:39	501	08:19	461



<b>time</b>	<b>pts</b>	<b>time</b>	<b>Pts</b>	<b>time</b>	<b>pts</b>	<b>time</b>	<b>pts</b>	<b>Time</b>	<b>pts</b>	<b>time</b>	<b>pts</b>
<u>08:20</u>	460	<u>09:00</u>	420	<u>09:40</u>	380	<u>10:20</u>	340	<u>11:00</u>	300	<u>11:40</u>	260
08:21	459	09:01	419	09:41	379	10:21	339	11:01	299	11:41	259
08:22	458	09:02	418	09:42	378	10:22	338	11:02	298	11:42	258
08:23	457	09:03	417	09:43	377	10:23	337	11:03	297	11:43	257
08:24	456	09:04	416	09:44	376	10:24	336	11:04	296	11:44	256
08:25	455	09:05	415	09:45	375	10:25	335	11:05	295	11:45	255
08:26	454	09:06	414	09:46	374	10:26	334	11:06	294	11:46	254
08:27	453	09:07	413	09:47	373	10:27	333	11:07	293	11:47	253
08:28	452	09:08	412	09:48	372	10:28	332	11:08	292	11:48	252
08:29	451	09:09	411	09:49	371	10:29	331	11:09	291	11:49	251
<u>08:30</u>	450	<u>09:10</u>	410	<u>09:50</u>	370	<u>10:30</u>	330	<u>11:10</u>	290	<u>11:50</u>	250
08:31	449	09:11	409	09:51	369	10:31	329	11:11	289	11:51	249
08:32	448	09:12	408	09:52	368	10:32	328	11:12	288	11:52	248
08:33	447	09:13	407	09:53	367	10:33	327	11:13	287	11:53	247
08:34	446	09:14	406	09:54	366	10:34	326	11:14	286	11:54	246
08:35	445	09:15	405	09:55	365	10:35	325	11:15	285	11:55	245
08:36	444	09:16	404	09:56	364	10:36	324	11:16	284	11:56	244
08:37	443	09:17	403	09:57	363	10:37	323	11:17	283	11:57	243
08:38	442	09:18	402	09:58	362	10:38	322	11:18	282	11:58	242
08:39	441	09:19	401	09:59	361	10:39	321	11:19	281	11:59	241
<u>08:40</u>	440	<u>09:20</u>	400	<u>10:00</u>	360	<u>10:40</u>	320	<u>11:20</u>	280	<u>12:00</u>	240
08:41	439	09:21	399	10:01	359	10:41	319	11:21	279	12:01	239
08:42	438	09:22	398	10:02	358	10:42	318	11:22	278	12:02	238
08:43	437	09:23	397	10:03	357	10:43	317	11:23	277	12:03	237
08:44	436	09:24	396	10:04	356	10:44	316	11:24	276	12:04	236
08:45	435	09:25	395	10:05	355	10:45	315	11:25	275	12:05	235
08:46	434	09:26	394	10:06	354	10:46	314	11:26	274	12:06	234
08:47	433	09:27	393	10:07	353	10:47	313	11:27	273	12:07	233
08:48	432	09:28	392	10:08	352	10:48	312	11:28	272	12:08	232
08:49	431	09:29	391	10:09	351	10:49	311	11:29	271	12:09	231
<u>08:50</u>	430	<u>09:30</u>	390	<u>10:10</u>	350	<u>10:50</u>	310	<u>11:30</u>	270	<u>12:10</u>	230
08:51	429	09:31	389	10:11	349	10:51	309	11:31	269	12:11	229
08:52	428	09:32	388	10:12	348	10:52	308	11:32	268	12:12	228
08:53	427	09:33	387	10:13	347	10:53	307	11:33	267	12:13	227
08:54	426	09:34	386	10:14	346	10:54	306	11:34	266	12:14	226
08:55	425	09:35	385	10:15	345	10:55	305	11:35	265	12:15	225
08:56	424	09:36	384	10:16	344	10:56	304	11:36	264	12:16	224
08:57	423	09:37	383	10:17	343	10:57	303	11:37	263	12:17	223
08:58	422	09:38	382	10:18	342	10:58	302	11:38	262	12:18	222
08:59	421	09:39	381	10:19	341	10:59	301	11:39	261	12:19	221



<u>time</u>	<u>pts</u>	<u>time</u>	<u>Pts</u>	<u>time</u>	<u>pts</u>	<u>time</u>	<u>pts</u>	<u>Time</u>	<u>pts</u>	<u>time</u>	<u>pts</u>
<u>12:20</u>	220	<u>13:00</u>	180	<u>13:40</u>	140	<u>14:20</u>	100	<u>15:00</u>	60	<u>15:40</u>	20
12:21	219	13:01	179	13:41	139	14:21	99	15:01	59	15:41	19
12:22	218	13:02	178	13:42	138	14:22	98	15:02	58	15:42	18
12:23	217	13:03	177	13:43	137	14:23	97	15:03	57	15:43	17
12:24	216	13:04	176	13:44	136	14:24	96	15:04	56	15:44	16
12:25	215	13:05	175	13:45	135	14:25	95	15:05	55	15:45	15
12:26	214	13:06	174	13:46	134	14:26	94	15:06	54	15:46	14
12:27	213	13:07	173	13:47	133	14:27	93	15:07	53	15:47	13
12:28	212	13:08	172	13:48	132	14:28	92	15:08	52	15:48	12
12:29	211	13:09	171	13:49	131	14:29	91	15:09	51	15:49	11
<u>12:30</u>	210	<u>13:10</u>	170	<u>13:50</u>	130	<u>14:30</u>	90	<u>15:10</u>	50	<u>15:50</u>	10
12:31	209	13:11	169	13:51	129	14:31	89	15:11	49	15:51	9
12:32	208	13:12	168	13:52	128	14:32	88	15:12	48	15:52	8
12:33	207	13:13	167	13:53	127	14:33	87	15:13	47	15:53	7
12:34	206	13:14	166	13:54	126	14:34	86	15:14	46	15:54	6
12:35	205	13:15	165	13:55	125	14:35	85	15:15	45	15:55	5
12:36	204	13:16	164	13:56	124	14:36	84	15:16	44	15:56	4
12:37	203	13:17	163	13:57	123	14:37	83	15:17	43	15:57	3
12:38	202	13:18	162	13:58	122	14:38	82	15:18	42	15:58	2
12:39	201	13:19	161	13:59	121	14:39	81	15:19	41	15:59	1
<u>12:40</u>	200	<u>13:20</u>	160	<u>14:00</u>	120	<u>14:40</u>	80	<u>15:20</u>	40	<u>16:00</u>	0
12:41	199	13:21	159	14:01	119	14:41	79	15:21	39		
12:42	198	13:22	158	14:02	118	14:42	78	15:22	38		
12:43	197	13:23	157	14:03	117	14:43	77	15:23	37		
12:44	196	13:24	156	14:04	116	14:44	76	15:24	36		
12:45	195	13:25	155	14:05	115	14:45	75	15:25	35		
12:46	194	13:26	154	14:06	114	14:46	74	15:26	34		
12:47	193	13:27	153	14:07	113	14:47	73	15:27	33		
12:48	192	13:28	152	14:08	112	14:48	72	15:28	32		
12:49	191	13:29	151	14:09	111	14:49	71	15:29	31		
<u>12:50</u>	190	<u>13:30</u>	150	<u>14:10</u>	110	<u>14:50</u>	70	<u>15:30</u>	30		
12:51	189	13:31	149	14:11	109	14:51	69	15:31	29		
12:52	188	13:32	148	14:12	108	14:52	68	15:32	28		
12:53	187	13:33	147	14:13	107	14:53	67	15:33	27		
12:54	186	13:34	146	14:14	106	14:54	66	15:34	26		
12:55	185	13:35	145	14:15	105	14:55	65	15:35	25		
12:56	184	13:36	144	14:16	104	14:56	64	15:36	24		
12:57	183	13:37	143	14:17	103	14:57	63	15:37	23		
12:58	182	13:38	142	14:18	102	14:58	62	15:38	22		
12:59	181	13:39	141	14:19	101	14:59	61	15:39	21		



**POINTS TABLE**

**COMBINED EVENT -  
Individual Boys & Girls: Under 13 (YD)  
Relay: Under 11 (YE) Under 9 (YF)**

**Appendix 5B4**

<u>time</u>	<u>pts</u>	<u>time</u>	<u>Pts</u>	<u>time</u>	<u>pts</u>	<u>time</u>	<u>pts</u>	<u>Time</u>	<u>pts</u>	<u>time</u>	<u>pts</u>
02:00	700	02:40	660	03:20	620	04:00	580	04:40	540	<b>05:20</b>	<b>500</b>
02:01	699	02:41	659	03:21	619	04:01	579	04:41	539	05:21	499
02:02	698	02:42	658	03:22	618	04:02	578	04:42	538	05:22	498
02:03	697	02:43	657	03:23	617	04:03	577	04:43	537	05:23	497
02:04	696	02:44	656	03:24	616	04:04	576	04:44	536	05:24	496
02:05	695	02:45	655	03:25	615	04:05	575	04:45	535	05:25	495
02:06	694	02:46	654	03:26	614	04:06	574	04:46	534	05:26	494
02:07	693	02:47	653	03:27	613	04:07	573	04:47	533	05:27	493
02:08	692	02:48	652	03:28	612	04:08	572	04:48	532	05:28	492
02:09	691	02:49	651	03:29	611	04:09	571	04:49	531	05:29	491
<u>02:10</u>	690	<u>02:50</u>	650	<u>03:30</u>	610	<u>04:10</u>	570	<u>04:50</u>	530	<u>05:30</u>	490
02:11	689	02:51	649	03:31	609	04:11	569	04:51	529	05:31	489
02:12	688	02:52	648	03:32	608	04:12	568	04:52	528	05:32	488
02:13	687	02:53	647	03:33	607	04:13	567	04:53	527	05:33	487
02:14	686	02:54	646	03:34	606	04:14	566	04:54	526	05:34	486
02:15	685	02:55	645	03:35	605	04:15	565	04:55	525	05:35	485
02:16	684	02:56	644	03:36	604	04:16	564	04:56	524	05:36	484
02:17	683	02:57	643	03:37	603	04:17	563	04:57	523	05:37	483
02:18	682	02:58	642	03:38	602	04:18	562	04:58	522	05:38	482
02:19	681	02:59	641	03:39	601	04:19	561	04:59	521	05:39	481
<u>02:20</u>	680	<u>03:00</u>	640	<u>03:40</u>	600	<u>04:20</u>	560	<u>05:00</u>	520	<u>05:40</u>	480
02:21	679	03:01	639	03:41	599	04:21	559	05:01	519	05:41	479
02:22	678	03:02	638	03:42	598	04:22	558	05:02	518	05:42	478
02:23	677	03:03	637	03:43	597	04:23	557	05:03	517	05:43	477
02:24	676	03:04	636	03:44	596	04:24	556	05:04	516	05:44	476
02:25	675	03:05	635	03:45	595	04:25	555	05:05	515	05:45	475
02:26	674	03:06	634	03:46	594	04:26	554	05:06	514	05:46	474
02:27	673	03:07	633	03:47	593	04:27	553	05:07	513	05:47	473
02:28	672	03:08	632	03:48	592	04:28	552	05:08	512	05:48	472
02:29	671	03:09	631	03:49	591	04:29	551	05:09	511	05:49	471
<u>02:30</u>	670	<u>03:10</u>	630	<u>03:50</u>	590	<u>04:30</u>	550	<u>05:10</u>	510	<u>05:50</u>	470
02:31	669	03:11	629	03:51	589	04:31	549	05:11	509	05:51	469
02:32	668	03:12	628	03:52	588	04:32	548	05:12	508	05:52	468
02:33	667	03:13	627	03:53	587	04:33	547	05:13	507	05:53	467
02:34	666	03:14	626	03:54	586	04:34	546	05:14	506	05:54	466
02:35	665	03:15	625	03:55	585	04:35	545	05:15	505	05:55	465
02:36	664	03:16	624	03:56	584	04:36	544	05:16	504	05:56	464
02:37	663	03:17	623	03:57	583	04:37	543	05:17	503	05:57	463
02:38	662	03:18	622	03:58	582	04:38	542	05:18	502	05:58	462
02:39	661	03:19	621	03:59	581	04:39	541	05:19	501	05:59	461



time	pts	time	Pts	time	pts	time	pts	time	pts	time	Pts
06:00	460	06:40	420	07:20	380	08:00	340	08:40	300	09:20	260
06:01	459	06:41	419	07:21	379	08:01	339	08:41	299	09:21	259
06:02	458	06:42	418	07:22	378	08:02	338	08:42	298	09:22	258
06:03	457	06:43	417	07:23	377	08:03	337	08:43	297	09:23	257
06:04	456	06:44	416	07:24	376	08:04	336	08:44	296	09:24	256
06:05	455	06:45	415	07:25	375	08:05	335	08:45	295	09:25	255
06:06	454	06:46	414	07:26	374	08:06	334	08:46	294	09:26	254
06:07	453	06:47	413	07:27	373	08:07	333	08:47	293	09:27	253
06:08	452	06:48	412	07:28	372	08:08	332	08:48	292	09:28	252
06:09	451	06:49	411	07:29	371	08:09	331	08:49	291	09:29	251
06:10	450	06:50	410	07:30	370	08:10	330	08:50	290	09:30	250
06:11	449	06:51	409	07:31	369	08:11	329	08:51	289	09:31	249
06:12	448	06:52	408	07:32	368	08:12	328	08:52	288	09:32	248
06:13	447	06:53	407	07:33	367	08:13	327	08:53	287	09:33	247
06:14	446	06:54	406	07:34	366	08:14	326	08:54	286	09:34	246
06:15	445	06:55	405	07:35	365	08:15	325	08:55	285	09:35	245
06:16	444	06:56	404	07:36	364	08:16	324	08:56	284	09:36	244
06:17	443	06:57	403	07:37	363	08:17	323	08:57	283	09:37	243
06:18	442	06:58	402	07:38	362	08:18	322	08:58	282	09:38	242
06:19	441	06:59	401	07:39	361	08:19	321	08:59	281	09:39	241
06:20	440	07:00	400	07:40	360	08:20	320	09:00	280	09:40	240
06:21	439	07:01	399	07:41	359	08:21	319	09:01	279	09:41	239
06:22	438	07:02	398	07:42	358	08:22	318	09:02	278	09:42	238
06:23	437	07:03	397	07:43	357	08:23	317	09:03	277	09:43	237
06:24	436	07:04	396	07:44	356	08:24	316	09:04	276	09:44	236
06:25	435	07:05	395	07:45	355	08:25	315	09:05	275	09:45	235
06:26	434	07:06	394	07:46	354	08:26	314	09:06	274	09:46	234
06:27	433	07:07	393	07:47	353	08:27	313	09:07	273	09:47	233
06:28	432	07:08	392	07:48	352	08:28	312	09:08	272	09:48	232
06:29	431	07:09	391	07:49	351	08:29	311	09:09	271	09:49	231
06:30	430	07:10	390	07:50	350	08:30	310	09:10	270	09:50	230
06:31	429	07:11	389	07:51	349	08:31	309	09:11	269	09:51	229
06:32	428	07:12	388	07:52	348	08:32	308	09:12	268	09:52	228
06:33	427	07:13	387	07:53	347	08:33	307	09:13	267	09:53	227
06:34	426	07:14	386	07:54	346	08:34	306	09:14	266	09:54	226
06:35	425	07:15	385	07:55	345	08:35	305	09:15	265	09:55	225
06:36	424	07:16	384	07:56	344	08:36	304	09:16	264	09:56	224
06:37	423	07:17	383	07:57	343	08:37	303	09:17	263	09:57	223
06:38	422	07:18	382	07:58	342	08:38	302	09:18	262	09:58	222
06:39	421	07:19	381	07:59	341	08:39	301	09:19	261	09:59	221



<u>time</u>	<u>pts</u>	<u>time</u>	<u>Pts</u>	<u>time</u>	<u>pts</u>	<u>time</u>	<u>pts</u>	<u>time</u>	<u>pts</u>	<u>time</u>	<u>Pts</u>
10:00	220	10:40	180	11:20	140	12:00	100	12:40	60	13:20	20
10:01	219	10:41	179	11:21	139	12:01	99	12:41	59	13:21	19
10:02	218	10:42	178	11:22	138	12:02	98	12:42	58	13:22	18
10:03	217	10:43	177	11:23	137	12:03	97	12:43	57	13:23	17
10:04	216	10:44	176	11:24	136	12:04	96	12:44	56	13:24	16
10:05	215	10:45	175	11:25	135	12:05	95	12:45	55	13:25	15
10:06	214	10:46	174	11:26	134	12:06	94	12:46	54	13:26	14
10:07	213	10:47	173	11:27	133	12:07	93	12:47	53	13:27	13
10:08	212	10:48	172	11:28	132	12:08	92	12:48	52	13:28	12
10:09	211	10:49	171	11:29	131	12:09	91	12:49	51	13:29	11
10:10	210	10:50	170	11:30	130	12:10	90	12:50	50	13:30	10
10:11	209	10:51	169	11:31	129	12:11	89	12:51	49	13:31	9
10:12	208	10:52	168	11:32	128	12:12	88	12:52	48	13:32	8
10:13	207	10:53	167	11:33	127	12:13	87	12:53	47	13:33	7
10:14	206	10:54	166	11:34	126	12:14	86	12:54	46	13:34	6
10:15	205	10:55	165	11:35	125	12:15	85	12:55	45	13:35	5
10:16	204	10:56	164	11:36	124	12:16	84	12:56	44	13:36	4
10:17	203	10:57	163	11:37	123	12:17	83	12:57	43	13:37	3
10:18	202	10:58	162	11:38	122	12:18	82	12:58	42	13:38	2
10:19	201	10:59	161	11:39	121	12:19	81	12:59	41	13:39	1
10:20	200	11:00	160	11:40	120	12:20	80	13:00	40	13:40	0
10:21	199	11:01	159	11:41	119	12:21	79	13:01	39		
10:22	198	11:02	158	11:42	118	12:22	78	13:02	38		
10:23	197	11:03	157	11:43	117	12:23	77	13:03	37		
10:24	196	11:04	156	11:44	116	12:24	76	13:04	36		
10:25	195	11:05	155	11:45	115	12:25	75	13:05	35		
10:26	194	11:06	154	11:46	114	12:26	74	13:06	34		
10:27	193	11:07	153	11:47	113	12:27	73	13:07	33		
10:28	192	11:08	152	11:48	112	12:28	72	13:08	32		
10:29	191	11:09	151	11:49	111	12:29	71	13:09	31		
10:30	190	11:10	150	11:50	110	12:30	70	13:10	30		
10:31	189	11:11	149	11:51	109	12:31	69	13:11	29		
10:32	188	11:12	148	11:52	108	12:32	68	13:12	28		
10:33	187	11:13	147	11:53	107	12:33	67	13:13	27		
10:34	186	11:14	146	11:54	106	12:34	66	13:14	26		
10:35	185	11:15	145	11:55	105	12:35	65	13:15	25		
10:36	184	11:16	144	11:56	104	12:36	64	13:16	24		
10:37	183	11:17	143	11:57	103	12:37	63	13:17	23		
10:38	182	11:18	142	11:58	102	12:38	62	13:18	22		
10:39	181	11:19	141	11:59	101	12:39	61	13:19	21		



**POINTS TABLE**

**COMBINED EVENT**

**Appendix 5B5**

**Individual Boys & Girls: Under 11 (YE) and Under 9 (YF)**

<b>time</b>	<b>pts</b>	<b>time</b>	<b>Pts</b>	<b>time</b>	<b>pts</b>	<b>time</b>	<b>pts</b>	<b>time</b>	<b>pts</b>	<b>time</b>	<b>Pts</b>
00:40	700	01:20	660	02:00	620	02:40	580	03:20	540	<b>04:00</b>	<b>500</b>
00:41	699	01:21	659	02:01	619	02:41	579	03:21	539	04:01	499
00:42	698	01:22	658	02:02	618	02:42	578	03:22	538	04:02	498
00:43	697	01:23	657	02:03	617	02:43	577	03:23	537	04:03	497
00:44	696	01:24	656	02:04	616	02:44	576	03:24	536	04:04	496
00:45	695	01:25	655	02:05	615	02:45	575	03:25	535	04:05	495
00:46	694	01:26	654	02:06	614	02:46	574	03:26	534	04:06	494
00:47	693	01:27	653	02:07	613	02:47	573	03:27	533	04:07	493
00:48	692	01:28	652	02:08	612	02:48	572	03:28	532	04:08	492
00:49	691	01:29	651	02:09	611	02:49	571	03:29	531	04:09	491
<u>00:50</u>	690	<u>01:30</u>	650	<u>02:10</u>	610	<u>02:50</u>	570	<u>03:30</u>	530	<u>04:10</u>	490
00:51	689	01:31	649	02:11	609	02:51	569	03:31	529	04:11	489
00:52	688	01:32	648	02:12	608	02:52	568	03:32	528	04:12	488
00:53	687	01:33	647	02:13	607	02:53	567	03:33	527	04:13	487
00:54	686	01:34	646	02:14	606	02:54	566	03:34	526	04:14	486
00:55	685	01:35	645	02:15	605	02:55	565	03:35	525	04:15	485
00:56	684	01:36	644	02:16	604	02:56	564	03:36	524	04:16	484
00:57	683	01:37	643	02:17	603	02:57	563	03:37	523	04:17	483
00:58	682	01:38	642	02:18	602	02:58	562	03:38	522	04:18	482
00:59	681	01:39	641	02:19	601	02:59	561	03:39	521	04:19	481
<u>01:00</u>	680	<u>01:40</u>	640	<u>02:20</u>	600	<u>03:00</u>	560	<u>03:40</u>	520	<u>04:20</u>	480
01:01	679	01:41	639	02:21	599	03:01	559	03:41	519	04:21	479
01:02	678	01:42	638	02:22	598	03:02	558	03:42	518	04:22	478
01:03	677	01:43	637	02:23	597	03:03	557	03:43	517	04:23	477
01:04	676	01:44	636	02:24	596	03:04	556	03:44	516	04:24	476
01:05	675	01:45	635	02:25	595	03:05	555	03:45	515	04:25	475
01:06	674	01:46	634	02:26	594	03:06	554	03:46	514	04:26	474
01:07	673	01:47	633	02:27	593	03:07	553	03:47	513	04:27	473
01:08	672	01:48	632	02:28	592	03:08	552	03:48	512	04:28	472
01:09	671	01:49	631	02:29	591	03:09	551	03:49	511	04:29	471
<u>01:10</u>	670	<u>01:50</u>	630	<u>02:30</u>	590	<u>03:10</u>	550	<u>03:50</u>	510	<u>04:30</u>	470
01:11	669	01:51	629	02:31	589	03:11	549	03:51	509	04:31	469
01:12	668	01:52	628	02:32	588	03:12	548	03:52	508	04:32	468
01:13	667	01:53	627	02:33	587	03:13	547	03:53	507	04:33	467
01:14	666	01:54	626	02:34	586	03:14	546	03:54	506	04:34	466
01:15	665	01:55	625	02:35	585	03:15	545	03:55	505	04:35	465
01:16	664	01:56	624	02:36	584	03:16	544	03:56	504	04:36	464
01:17	663	01:57	623	02:37	583	03:17	543	03:57	503	04:37	463
01:18	662	01:58	622	02:38	582	03:18	542	03:58	502	04:38	462
01:19	661	01:59	621	02:39	581	03:19	541	03:59	501	04:39	461



<u>time</u>	<u>pts</u>	<u>time</u>	<u>Pts</u>	<u>time</u>	<u>pts</u>	<u>time</u>	<u>pts</u>	<u>time</u>	<u>pts</u>	<u>time</u>	<u>Pts</u>
04:40	460	05:20	420	06:00	380	06:40	340	07:20	300	08:00	260
04:41	459	05:21	419	06:01	379	06:41	339	07:21	299	08:01	259
04:42	458	05:22	418	06:02	378	06:42	338	07:22	298	08:02	258
04:43	457	05:23	417	06:03	377	06:43	337	07:23	297	08:03	257
04:44	456	05:24	416	06:04	376	06:44	336	07:24	296	08:04	256
04:45	455	05:25	415	06:05	375	06:45	335	07:25	295	08:05	255
04:46	454	05:26	414	06:06	374	06:46	334	07:26	294	08:06	254
04:47	453	05:27	413	06:07	373	06:47	333	07:27	293	08:07	253
04:48	452	05:28	412	06:08	372	06:48	332	07:28	292	08:08	252
04:49	451	05:29	411	06:09	371	06:49	331	07:29	291	08:09	251
04:50	450	05:30	410	06:10	370	06:50	330	07:30	290	08:10	250
04:51	449	05:31	409	06:11	369	06:51	329	07:31	289	08:11	249
04:52	448	05:32	408	06:12	368	06:52	328	07:32	288	08:12	248
04:53	447	05:33	407	06:13	367	06:53	327	07:33	287	08:13	247
04:54	446	05:34	406	06:14	366	06:54	326	07:34	286	08:14	246
04:55	445	05:35	405	06:15	365	06:55	325	07:35	285	08:15	245
04:56	444	05:36	404	06:16	364	06:56	324	07:36	284	08:16	244
04:57	443	05:37	403	06:17	363	06:57	323	07:37	283	08:17	243
04:58	442	05:38	402	06:18	362	06:58	322	07:38	282	08:18	242
04:59	441	05:39	401	06:19	361	06:59	321	07:39	281	08:19	241
05:00	440	05:40	400	06:20	360	07:00	320	07:40	280	08:20	240
05:01	439	05:41	399	06:21	359	07:01	319	07:41	279	08:21	239
05:02	438	05:42	398	06:22	358	07:02	318	07:42	278	08:22	238
05:03	437	05:43	397	06:23	357	07:03	317	07:43	277	08:23	237
05:04	436	05:44	396	06:24	356	07:04	316	07:44	276	08:24	236
05:05	435	05:45	395	06:25	355	07:05	315	07:45	275	08:25	235
05:06	434	05:46	394	06:26	354	07:06	314	07:46	274	08:26	234
05:07	433	05:47	393	06:27	353	07:07	313	07:47	273	08:27	233
05:08	432	05:48	392	06:28	352	07:08	312	07:48	272	08:28	232
05:09	431	05:49	391	06:29	351	07:09	311	07:49	271	08:29	231
05:10	430	05:50	390	06:30	350	07:10	310	07:50	270	08:30	230
05:11	429	05:51	389	06:31	349	07:11	309	07:51	269	08:31	229
05:12	428	05:52	388	06:32	348	07:12	308	07:52	268	08:32	228
05:13	427	05:53	387	06:33	347	07:13	307	07:53	267	08:33	227
05:14	426	05:54	386	06:34	346	07:14	306	07:54	266	08:34	226
05:15	425	05:55	385	06:35	345	07:15	305	07:55	265	08:35	225
05:16	424	05:56	384	06:36	344	07:16	304	07:56	264	08:36	224
05:17	423	05:57	383	06:37	343	07:17	303	07:57	263	08:37	223
05:18	422	05:58	382	06:38	342	07:18	302	07:58	262	08:38	222
05:19	421	05:59	381	06:39	341	07:19	301	07:59	261	08:39	221





<u>time</u>	<u>pts</u>	<u>time</u>	<u>Pts</u>	<u>time</u>	<u>pts</u>	<u>time</u>	<u>pts</u>	<u>time</u>	<u>pts</u>	<u>time</u>	<u>Pts</u>
08:40	220	09:20	180	10:00	140	10:40	100	11:20	60	12:00	20
08:41	219	09:21	179	10:01	139	10:41	99	11:21	59	12:01	19
08:42	218	09:22	178	10:02	138	10:42	98	11:22	58	12:02	18
08:43	217	09:23	177	10:03	137	10:43	97	11:23	57	12:03	17
08:44	216	09:24	176	10:04	136	10:44	96	11:24	56	12:04	16
08:45	215	09:25	175	10:05	135	10:45	95	11:25	55	12:05	15
08:46	214	09:26	174	10:06	134	10:46	94	11:26	54	12:06	14
08:47	213	09:27	173	10:07	133	10:47	93	11:27	53	12:07	13
08:48	212	09:28	172	10:08	132	10:48	92	11:28	52	12:08	12
08:49	211	09:29	171	10:09	131	10:49	91	11:29	51	12:09	11
08:50	210	09:30	170	10:10	130	10:50	90	11:30	50	12:10	10
08:51	209	09:31	169	10:11	129	10:51	89	11:31	49	12:11	9
08:52	208	09:32	168	10:12	128	10:52	88	11:32	48	12:12	8
08:53	207	09:33	167	10:13	127	10:53	87	11:33	47	12:13	7
08:54	206	09:34	166	10:14	126	10:54	86	11:34	46	12:14	6
08:55	205	09:35	165	10:15	125	10:55	85	11:35	45	12:15	5
08:56	204	09:36	164	10:16	124	10:56	84	11:36	44	12:16	4
08:57	203	09:37	163	10:17	123	10:57	83	11:37	43	12:17	3
08:58	202	09:38	162	10:18	122	10:58	82	11:38	42	12:18	2
08:59	201	09:39	161	10:19	121	10:59	81	11:39	41	12:19	1
09:00	200	09:40	160	10:20	120	11:00	80	11:40	40	12:20	0
09:01	199	09:41	159	10:21	119	11:01	79	11:41	39		
09:02	198	09:42	158	10:22	118	11:02	78	11:42	38		
09:03	197	09:43	157	10:23	117	11:03	77	11:43	37		
09:04	196	09:44	156	10:24	116	11:04	76	11:44	36		
09:05	195	09:45	155	10:25	115	11:05	75	11:45	35		
09:06	194	09:46	154	10:26	114	11:06	74	11:46	34		
09:07	193	09:47	153	10:27	113	11:07	73	11:47	33		
09:08	192	09:48	152	10:28	112	11:08	72	11:48	32		
09:09	191	09:49	151	10:29	111	11:09	71	11:49	31		
09:10	190	09:50	150	10:30	110	11:10	70	11:50	30		
09:11	189	09:51	149	10:31	109	11:11	69	11:51	29		
09:12	188	09:52	148	10:32	108	11:12	68	11:52	28		
09:13	187	09:53	147	10:33	107	11:13	67	11:53	27		
09:14	186	09:54	146	10:34	106	11:14	66	11:54	26		
09:15	185	09:55	145	10:35	105	11:15	65	11:55	25		
09:16	184	09:56	144	10:36	104	11:16	64	11:56	24		
09:17	183	09:57	143	10:37	103	11:17	63	11:57	23		
09:18	182	09:58	142	10:38	102	11:18	62	11:58	22		
09:19	181	09:59	141	10:39	101	11:19	61	11:59	21		



Figure 1 - Indoor or Night Range Light Requirements (in Lux)

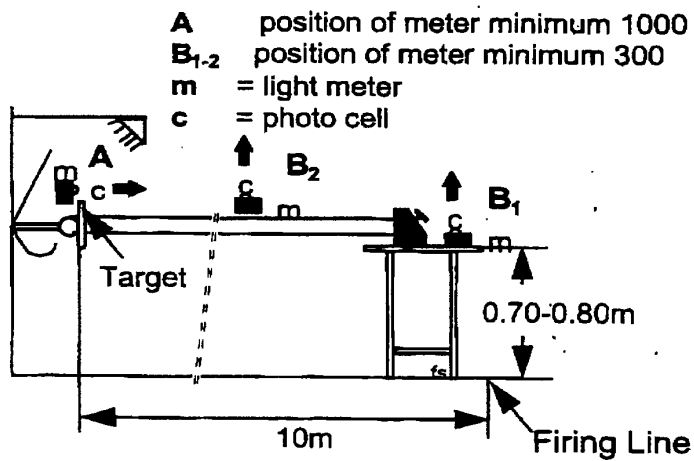


Figure 2 – The Pistol Grip

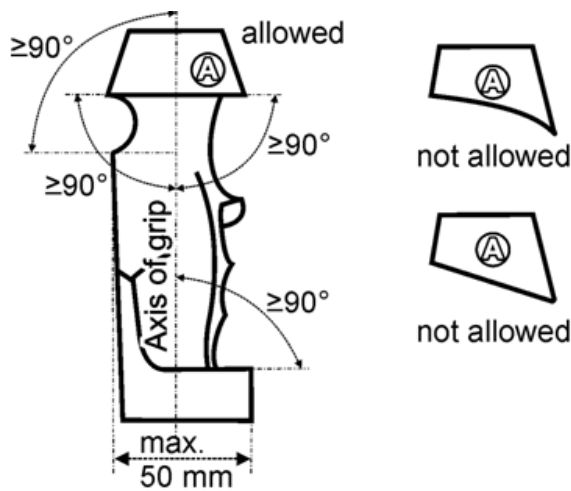


Figure 3 – Bends in the Grip

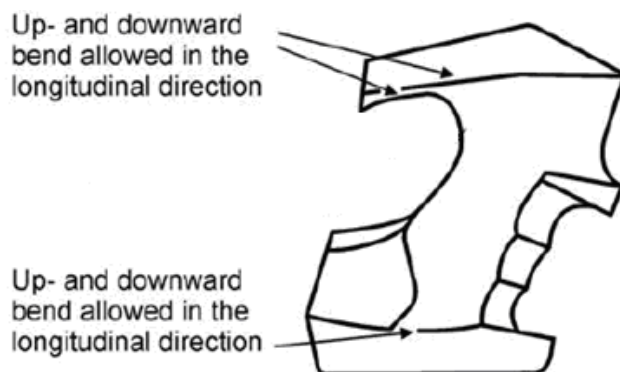




Figure 4 – The Thumb in the Grip

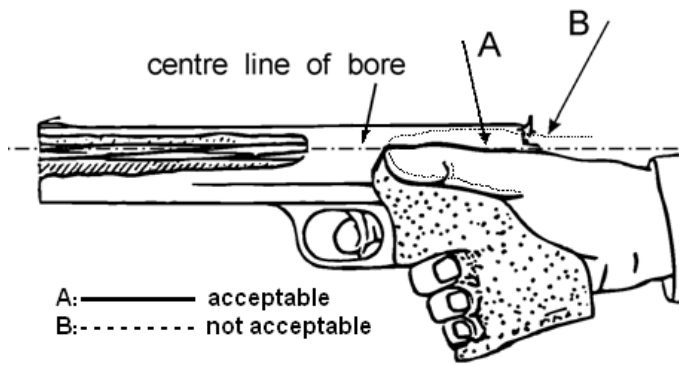
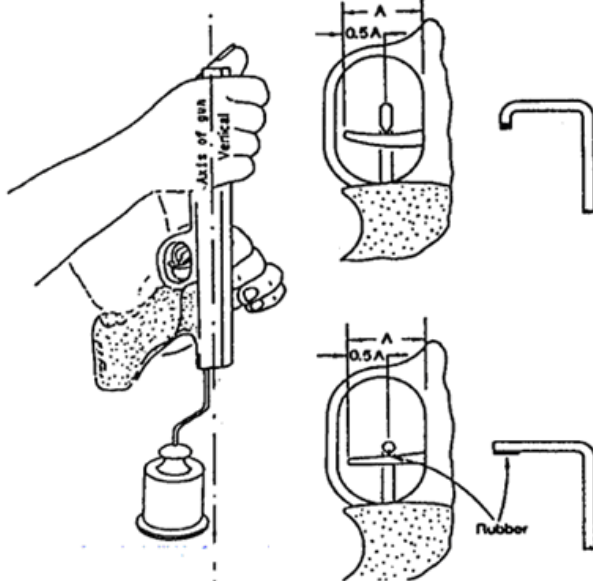


Figure 5 – Measuring the Trigger Weight



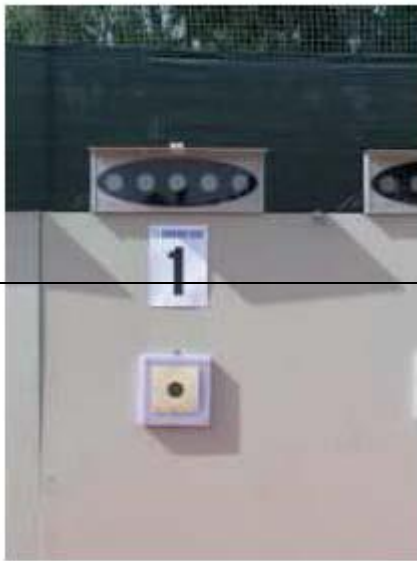
Measuring the Weight of the Trigger Pull

Figure 6 – Mechanical Targets

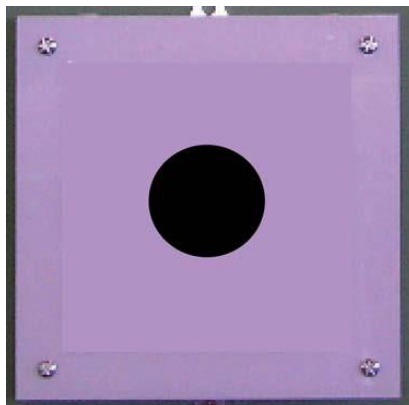




**Figure 7 – Electronic Pellet Target**



**Figure 8 – Laser Target**

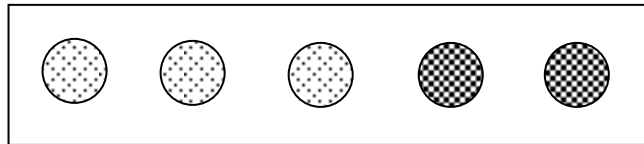
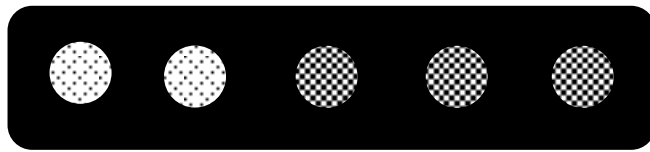


**Figure 9 – Laser Precision Target**





Figure 10 – Indicators (Result Display Lights)



*(Black & white draw for impression B&W)*

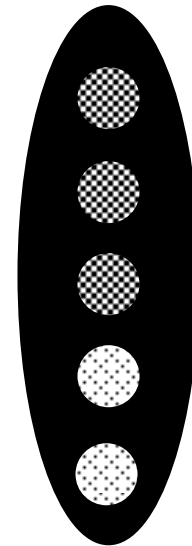
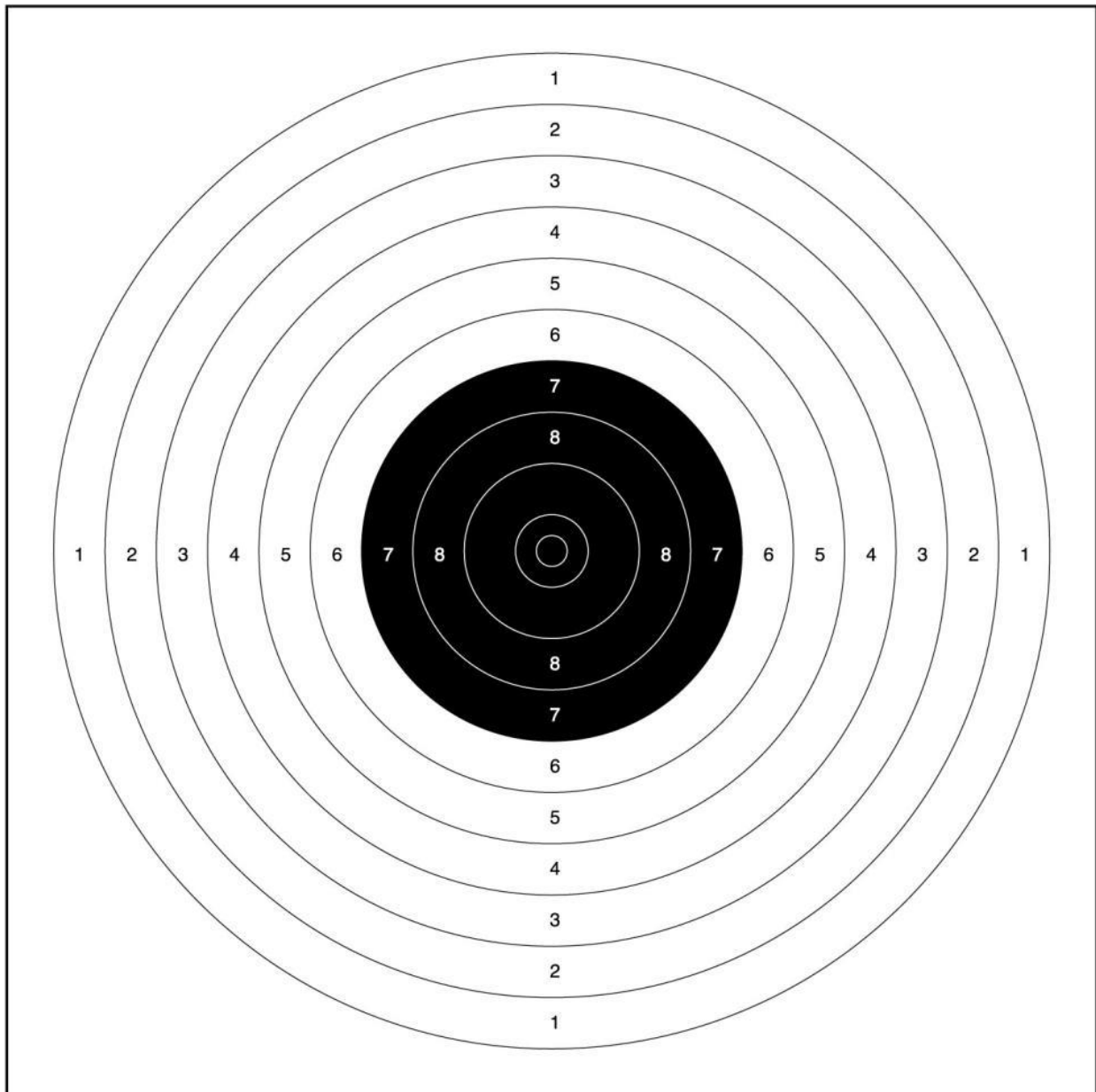




Figure 11 – The Precision Target

<b>10 ring</b>	11.5 mm ( $\pm 0.1$ mm)	<b>5 ring</b>	91.5 mm ( $\pm 0.5$ mm)
<b>9 ring</b>	27.5 mm ( $\pm 0.1$ mm)	<b>4 ring</b>	107.5 mm ( $\pm 0.5$ mm)
<b>8 ring</b>	43.5 mm ( $\pm 0.2$ mm)	<b>3 ring</b>	123.5 mm ( $\pm 0.5$ mm)
<b>7 ring</b>	59.5 mm ( $\pm 0.5$ mm)	<b>2 ring</b>	139.5 mm ( $\pm 0.5$ mm)
<b>6 ring</b>	75.5 mm ( $\pm 0.5$ mm)	<b>1 ring</b>	155.5 mm ( $\pm 0.5$ mm)



**Central ten: 5.0 mm (+/- 0.1mm)**  
**Black from 7 to 10 rings = 59.5 mm**  
**Ring thickness: 0.1 mm to 0.2 mm**  
**Minimum visible size of target card 170 mm x 170 mm**