



Sailing Measurement, a Basic Guide

Andy Wibroe
And
Bas Edmonds





An Introduction to Sail measurement

Andy Wibroe & Bas Edmonds



Andy Wibroe

RYA Technical Coordinator, Racing



International Sailing Federation Sail Measurement Course



- A one day course
- No Prior Knowledge expected
- Contains standard principles for measurement in general
- Originally intended for In-House Certification (IHC)
- Run on behalf of ISAF by the RYA in the UK
- Used to train ALL measurers in the UK (that the RYA approve)



Aim of the full Course

- To convey to potential Measurers the methods and techniques to be employed to achieve accurate, consistent and repeatable results when measuring.



Aim of Course

- To convey to potential Measurers the methods and techniques to be employed to achieve accurate, consistent and repeatable results when measuring.



Today's topics;

- To look at some standard measurement techniques & principles
- To give you a flavour for the full course
- To practically measure some sails
- To look at how the techniques in the course relate to class rules



To start – Which class?

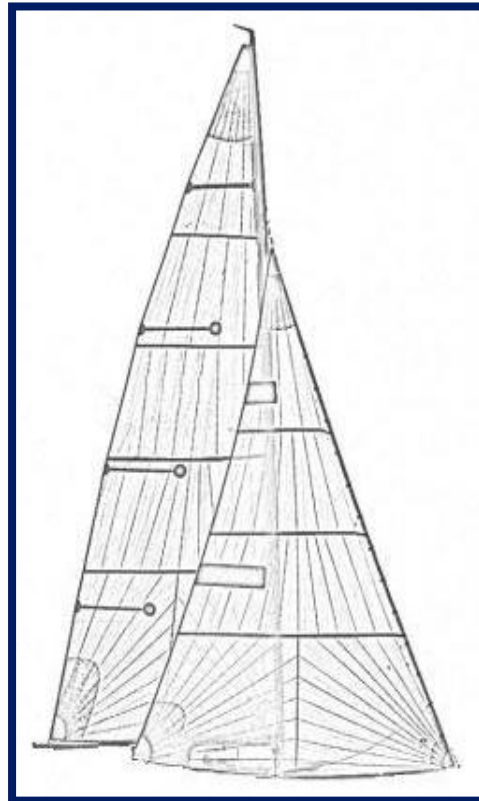



- Who cares?!

It makes no difference from the standard measurement point of view

- If you are interested it's a 6M

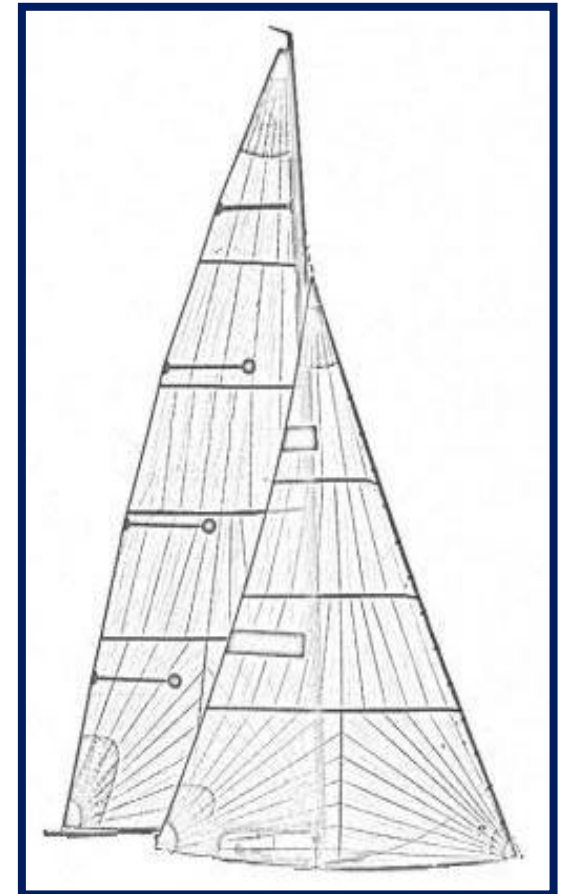



Standard Measurement Rules?



Racing Rules of Sailing
2013-2016



How many of you have seen this book before?

Racing Rules of Sailing - RRS



Equipment rules of Sailing - ERS

How many of you have seen this book before?

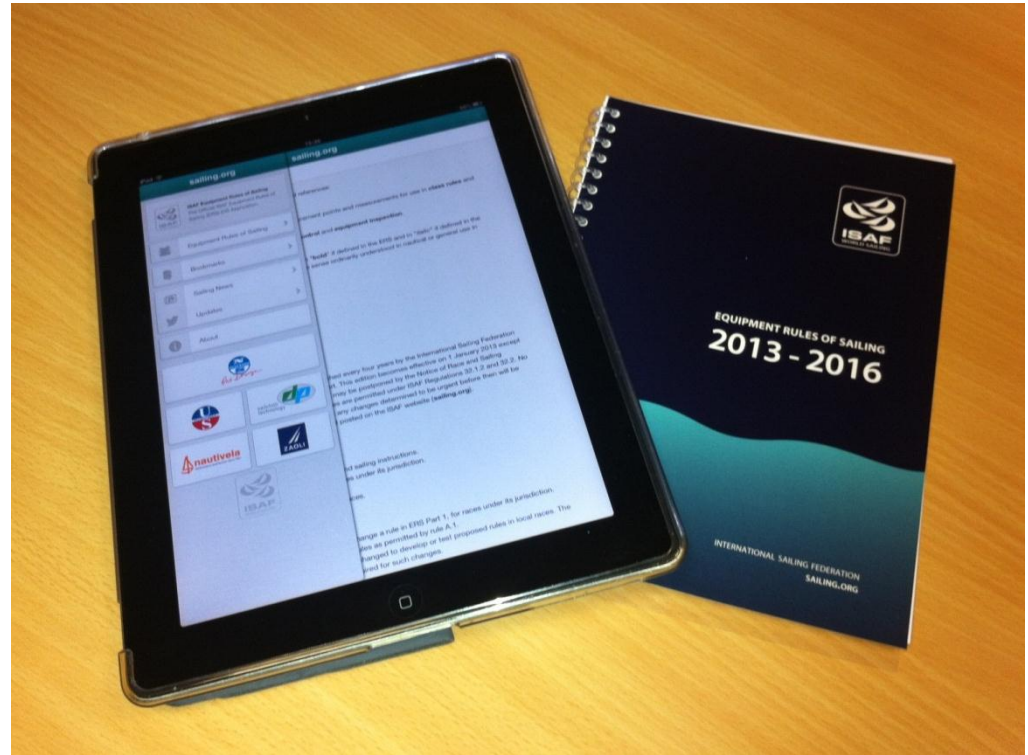



ERS Overview

In 3 Parts

- Part I - Use of Equipment
- Part II - Definitions
- Part III - Rules Governing Equipment Control and Inspection
- Terminology – **BOLD = Equipment Rules of Sailing (ERS) definition**
italic = Racing Rules of Sailing (RRS) definition

Revised every 4 years



Making Rules applicable?

- Whilst the RRS are turned on by default to govern boats whilst racing
 - “Racing shall be governed by *rules* as defined in the *racing rules of sailing*”, *Rule*: “The rules in this book including definitions, race signals, introduction, preambles....”
- The ERS are not always turned on by default to govern both boats whilst racing and the control of equipment during measurement
- The ERS have to be turned on by the class rules
 - An excerpt from the National Solo Class rules:
 - “A.5.2 Except where used in headings, when a term is printed in “**bold**” the definition in the ERS applies.”
 - “(a) The ERS Part I – Use of Equipment shall apply.”



The ERS and Class Rules Ethos

C.2.2 Closed Class Rules

- **Class rules** where anything not specifically permitted by the **class rules** is prohibited

C.2.3 Open Class Rules

- **Class rules** where anything not specifically prohibited by the **class rules** is permitted

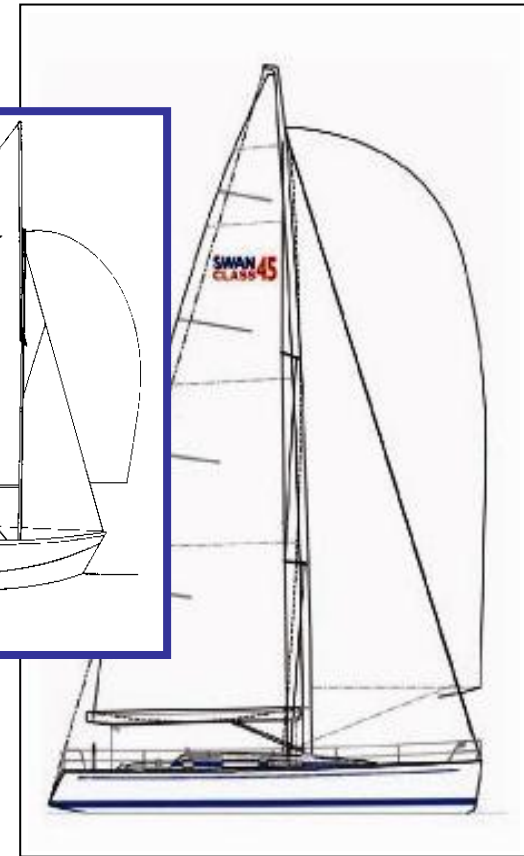
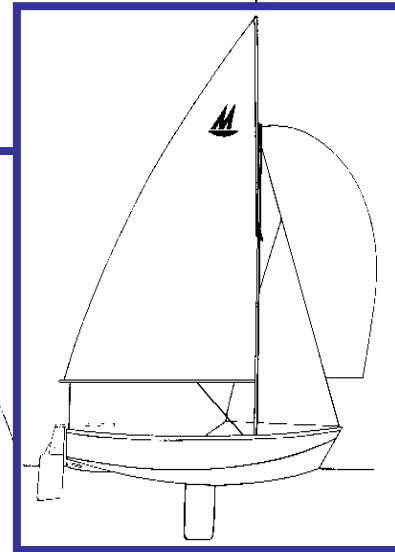
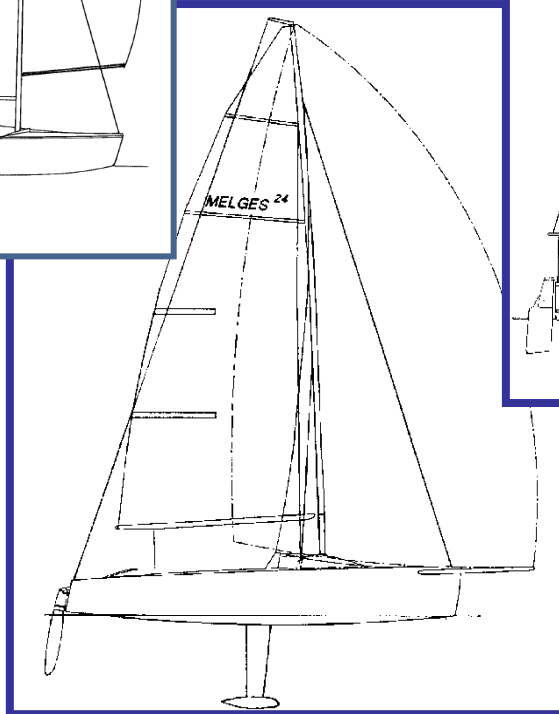
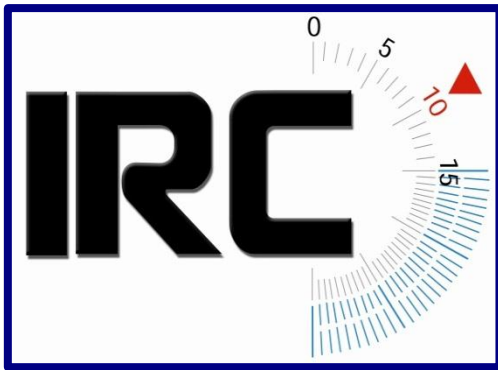
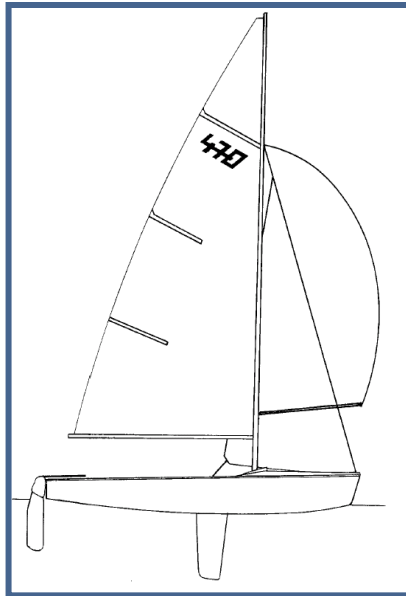
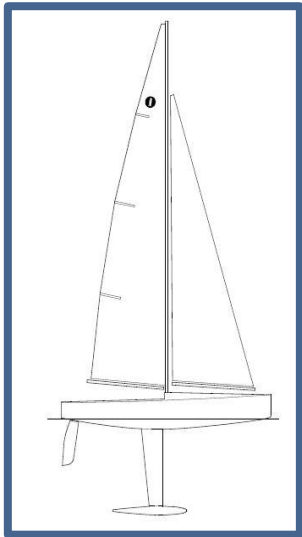



Before Moving on to some measurement...

- Which tools should a sail measurer have in their tool box?
 - Measuring tapes
 - Paper/ Tape
 - Pens Pencils
 - Certification marks
 - Sail number templates
 - Set Square
 - Scissors



Tapes





Tapes





Tapes

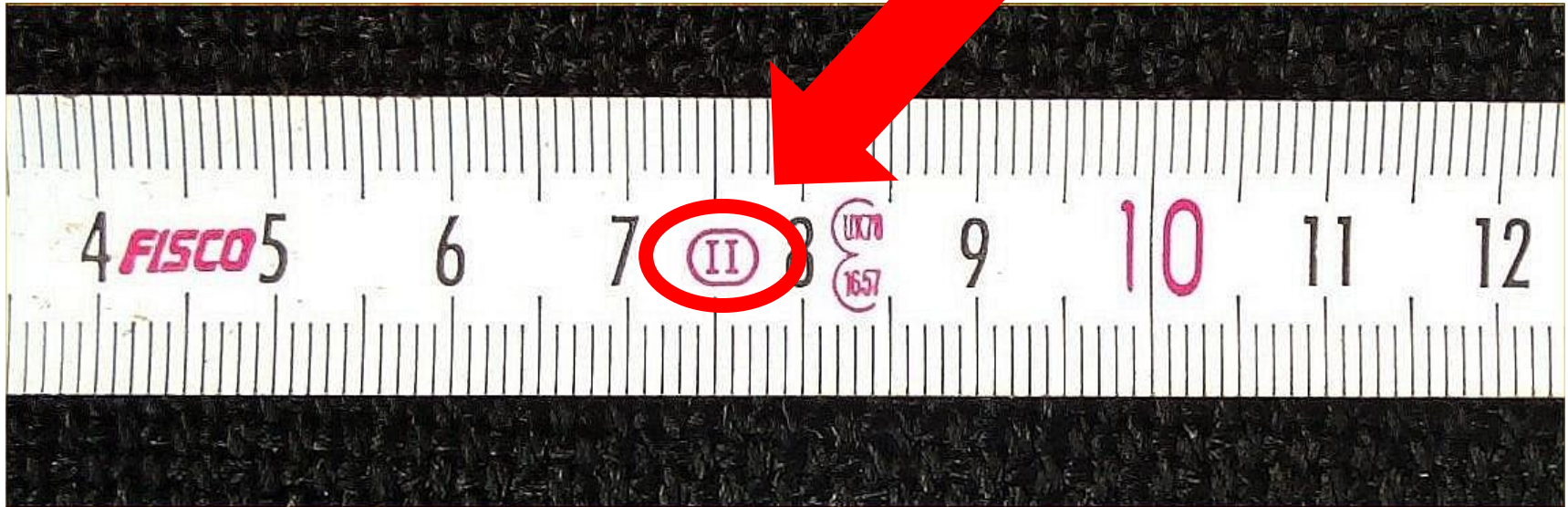

Recommended - EC Class II or higher



Tapes

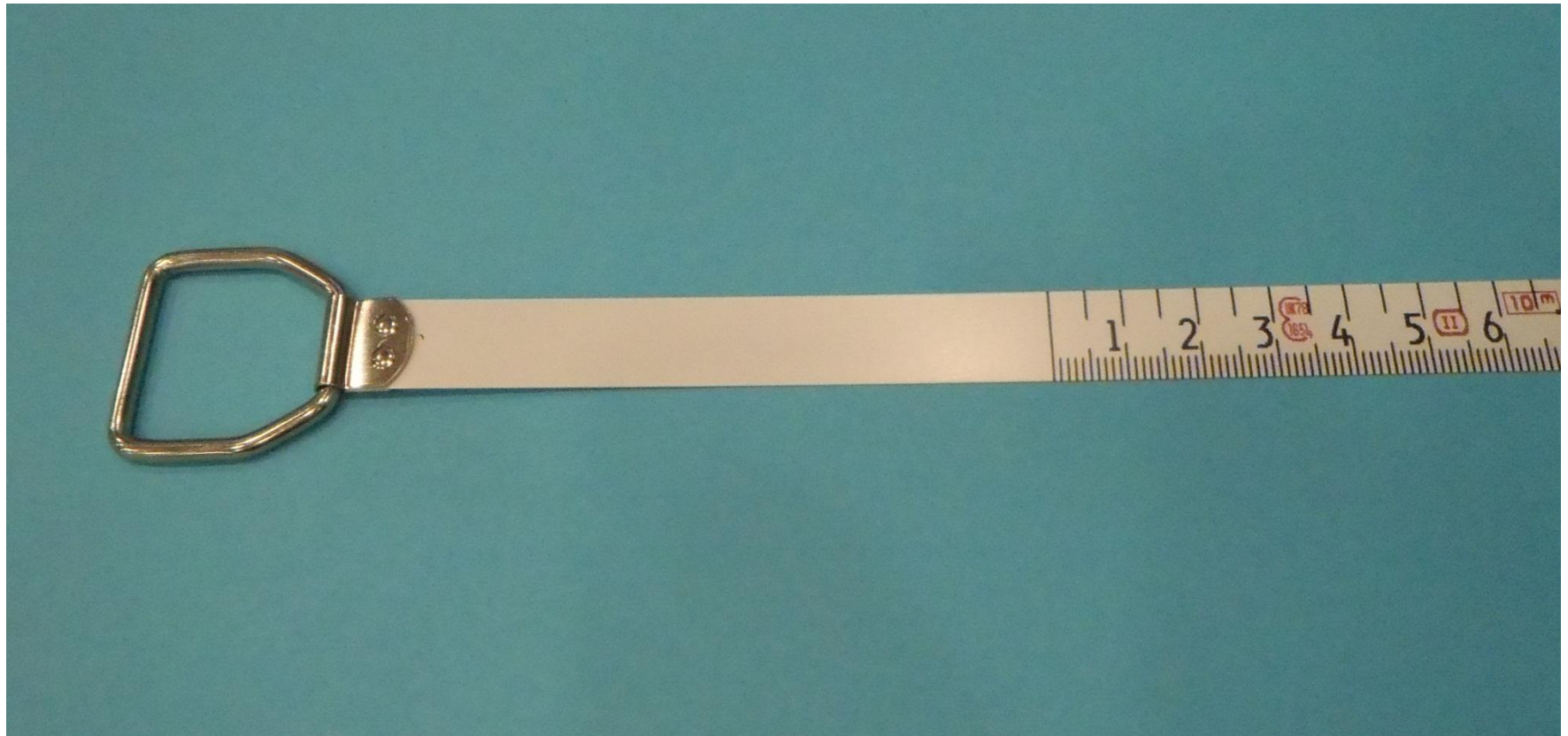

Tape with offset zero



Paper and Tape





Pens and Pencils





Certification Marks





Certifying a sail & Signing over the mark

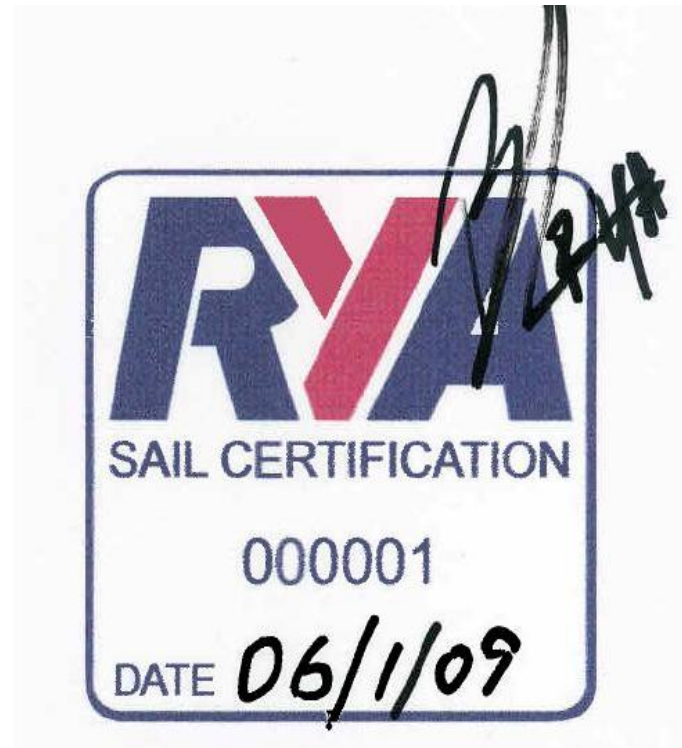



Sail Number Templates

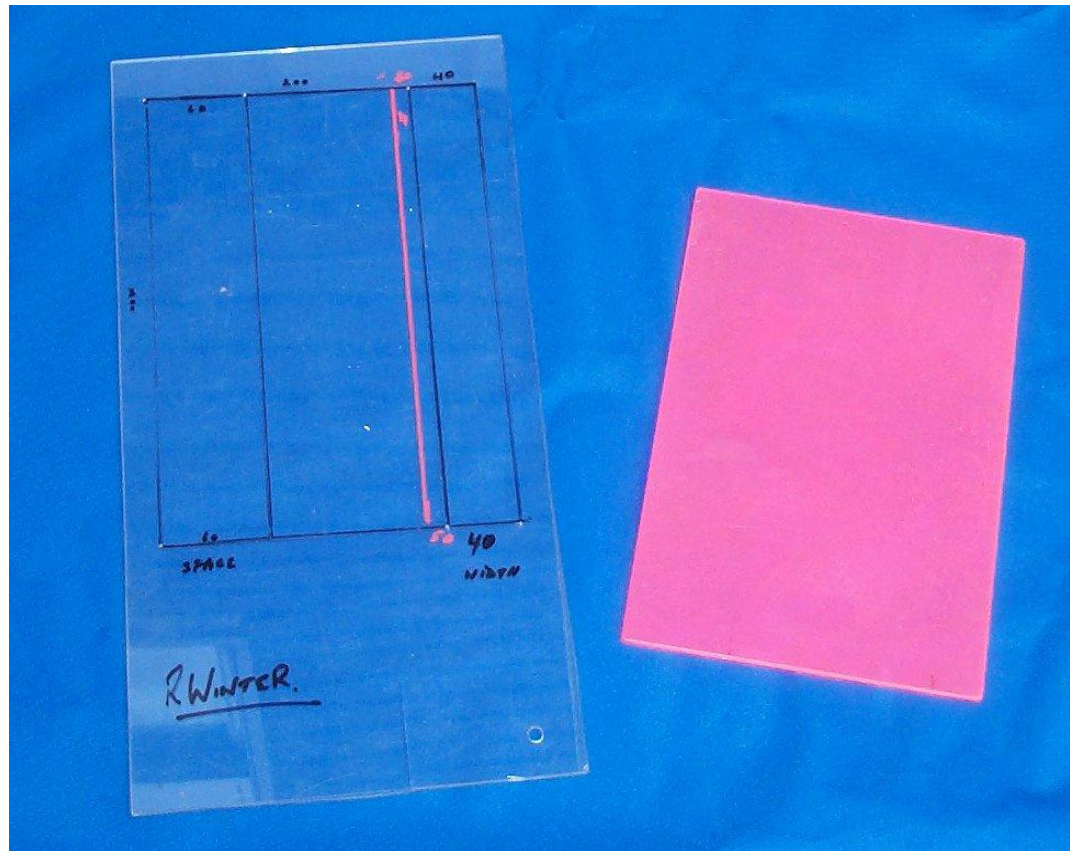



Set Square (at 90° to)

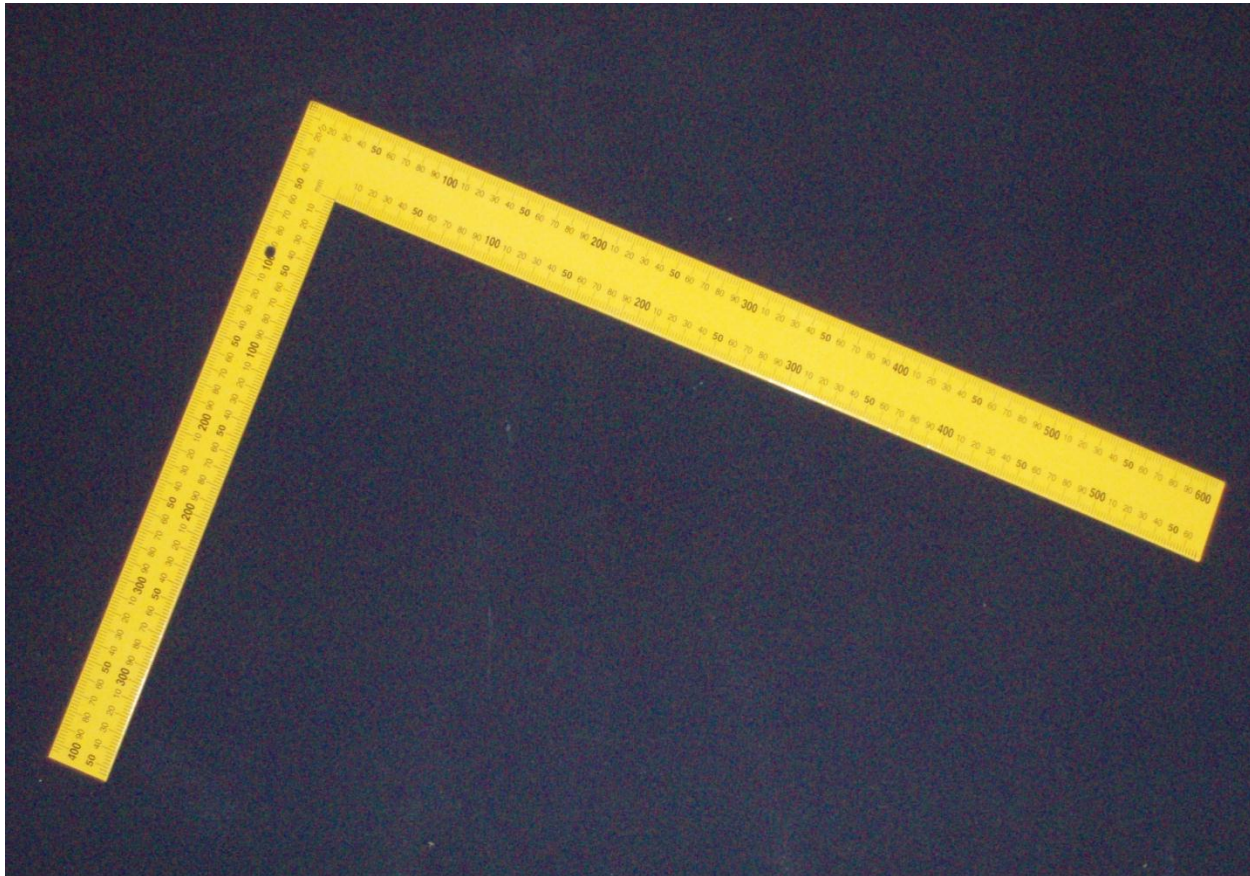



Scissors





ERS H.5.1 Condition of the Sail

For measurement the **sail** shall:

- (a) be dry,
- (b) not be attached to **spars** or **rigging**,
- (c) unless the **class rules** prescribe otherwise, have all battens removed,
- (d) have pockets of any type flattened out,
- (e) have just sufficient tension applied to remove wrinkles across the line of the measurement being taken,
- (f) have only one measurement taken at a time, and
- (g) be weighed with all **attachments**



Condition for Measurement



Flattened
out;

before and
after flaking



Condition for Measurement before and after flaking





Practical Conditions for measurement!



To recap

- We now have a basic understanding of the ERS
- We have a basic understanding of sail measurement and class rules
- Now lets check the 420 mainsail for a basic measurement and see if it complies with its **class rules**
- **Leech length**



Within the 420 class rules the following is stated:

- G.3 MAINSAIL
- G.3.3 DIMENSIONS

	Min	Max
– Leech length		5400mm

The sails section of the class rules is in part G,
We can then assume that the associated
definitions in the ERS will be in part G...



The ERS Part G – Sail Definitions

- We know we are looking for the leech.
- The leech in the ERS is defined as;
 - “G.2.2 **Leech**; The aft edge.”
- This much was obvious but where do we measure to/from?
- The **head** and **clew**?
- They are defined as:
 - “G.3.1 **Clew**; The region where the foot and leech meet.”
 - “G.3.2 **Head**; The region at the top.”
- Can we measure from the clew to the head and get accurate, consistent and repeatable results?
- NO! We need something more



Looking further afield in part G of the ERS

- We have a clearly defined measurement for **Leech length!**
 - G.7.2 **Leech length**; The distance between the **head point** and the **clew point**.
- Within this definition there are further definitions (highlighted in bold)
- These are defined as
 - “G.4.1 **Clew Point**; The intersection of the **foot** and the **leech**, each extended as necessary.”
 - “G.4.2 **Head Point** (Mainsail); The intersection of the **luff**, extended as necessary, and the line through the highest point of the **sail** at 90 degrees to the **luff**.”
 - These also have further definitions which are defined as;
 - “G.2.1 **Foot**; The bottom edge.”
 - “G.2.2 **Leech**; The aft edge.”
 - “G.2.3 **Luff**; The fore edge.”



Expanding out the definition

- **Leech length** now reads:
 - The distance between the (intersection of the (fore edge) extended as necessary, and the line through the highest point of the **sail** at 90 degrees to the (fore edge)) and the intersection of ((the bottom edge) and the (aft edge) each extended as necessary).
- Whilst this may seem a bit wordy, it is sometimes necessary to carry out this exercise to fully appreciate the definitions.
- Lets see this in practice, A picture says 1000 words....



Corner Measurement Points

G.4.1 Clew Point

The intersection of the **foot** and the **leech**, each extended as necessary

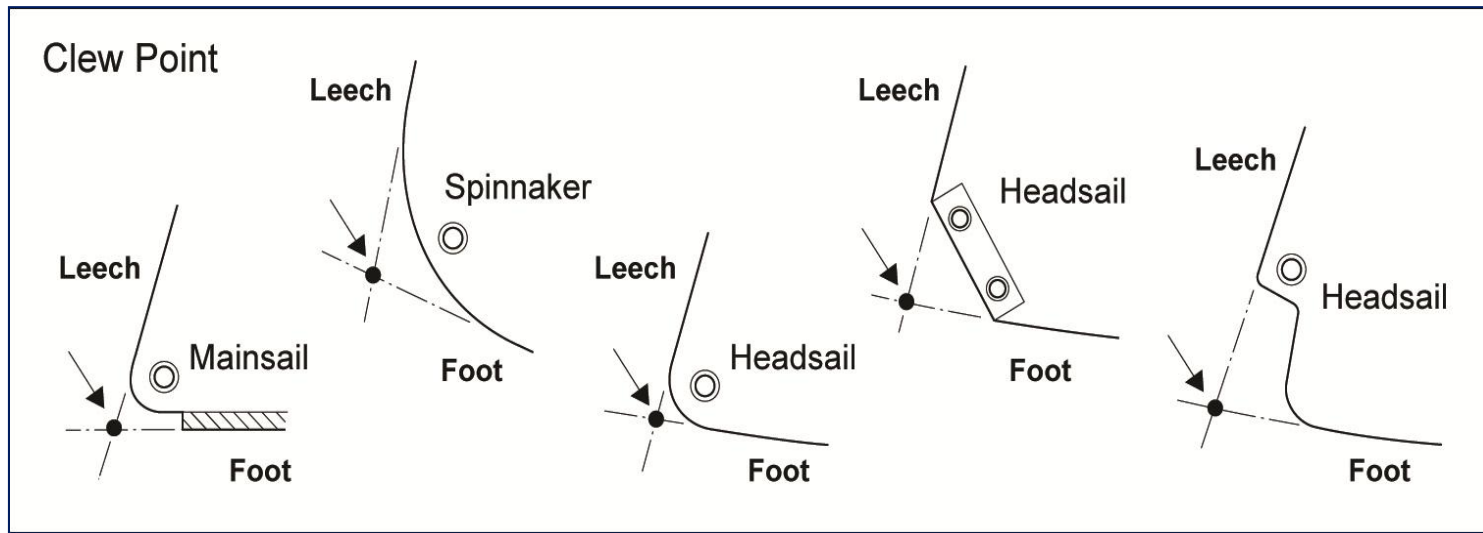



Corner Measurement Points

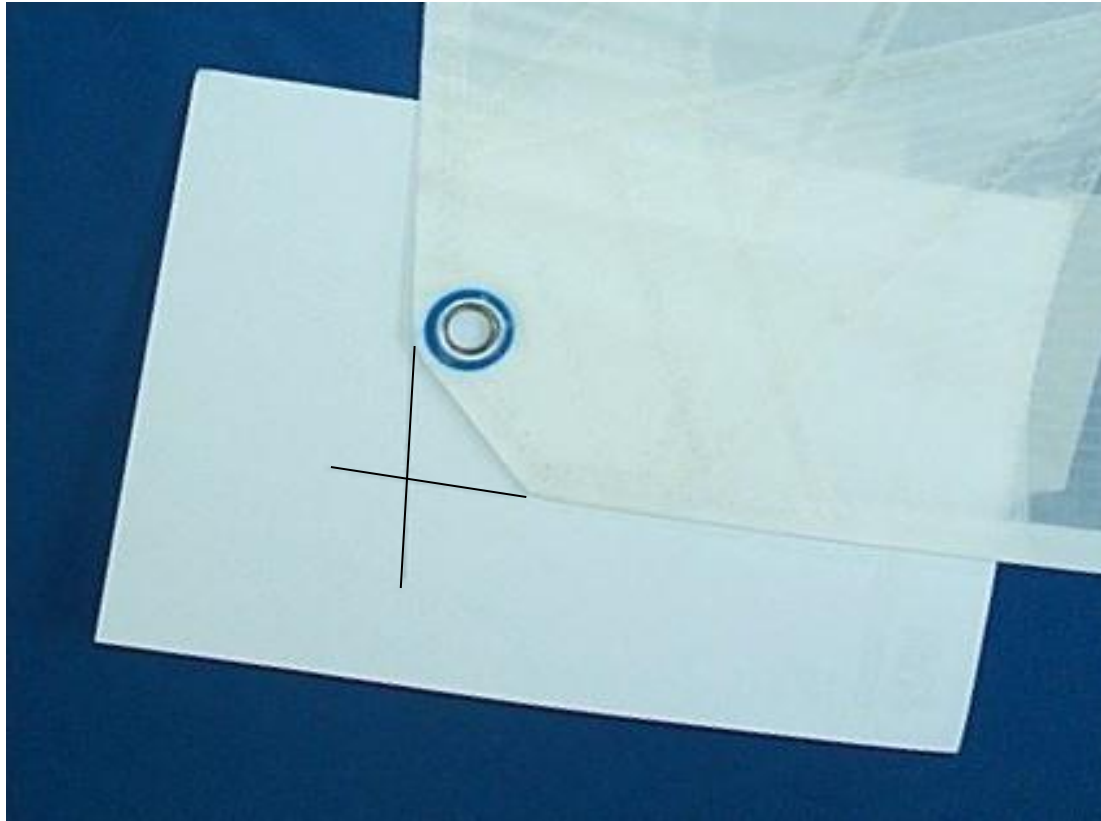

Clew Point



Head Measurement Point

•G.4.2 (a) MAINSAIL: The intersection of the **luff**, extended as necessary, and the line through the highest point of the sail at 90° to the **luff**.

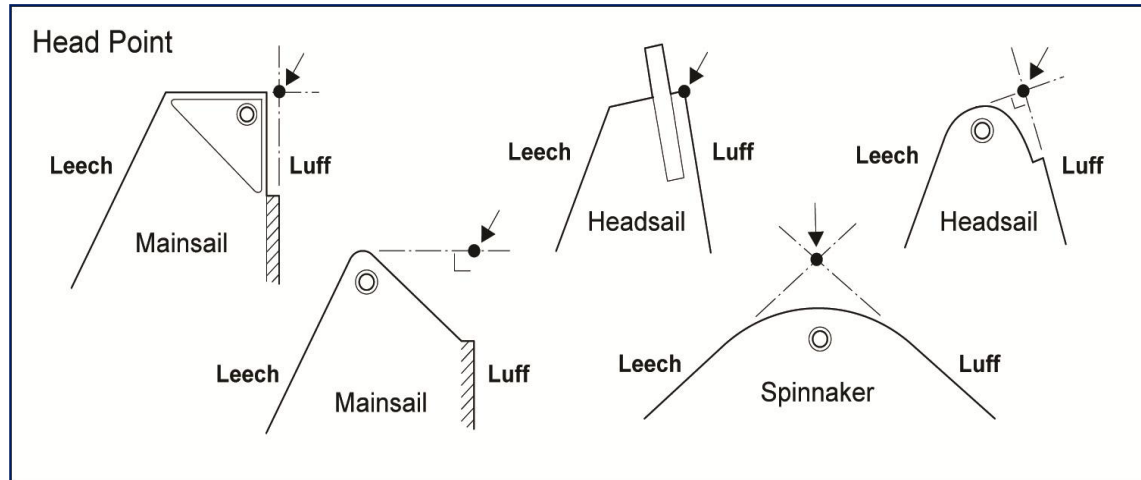



Mainsail



Where is the head point?

MAINSAIL: The intersection of the **luff**, extended as necessary, and the line through the highest point of the **sail** at 90° to the **luff**.

Head point



Lets now measure the **leech length** on the 420 mainsail to check against the **class rules!** (Max 5400mm)



Lengths



- leech length - remember to flake before measuring



As you probably all have a copy of the RRS lets look at Appendix G to the RRS

RRS G1.3(c)

National letters shall be placed above the sail number

NB the RYA prescribe to this rule: The national letters may be placed in front of or above the sail numbers.



Yes

In this case class rules override the RRS (RRS G5)



Is this boat compliant?





Is this boat compliant?

RRS - G1.3(e)

The national letters and sail number shall be displayed on both side of a headsail whose clew can be extended behind the mast 30% or more of the mainsail foot length... (A 130% overlapping headsail)





Some more examples - are they compliant?





Some more examples - are they compliant?

RRS - G1.2(a)

National letters and sail numbers shall be in capital letters and Arabic numerals, clearly legible and of the same colour.

Commercially available typefaces giving the same or better legibility than Helvetica are acceptable.





Some more examples - are they compliant?





Some more examples - are they compliant?



*RRS - G1.2(a)
National letters and sail numbers shall be in capital letters and Arabic numerals, clearly legible and of the same colour. Commercially available typefaces giving the same or better legibility than Helvetica are acceptable.*



Some more examples - are they compliant?





Some more examples - are they compliant?

RRS – G1.3

(a) Except as provided in rules G1.3(d) and G1.3(e), class insignia, national letters and sail numbers shall, if possible, be wholly above an arc whose centre is the head point and whose radius is 60% of the leech length. They shall be placed at different heights on the two sides of the sail, those on the starboard side being uppermost.

HOWEVER

(b) The class insignia shall be placed above the national letters. If the class insignia is of such design that two of them coincide when placed back to back on both sides of the sail, they may be so placed.

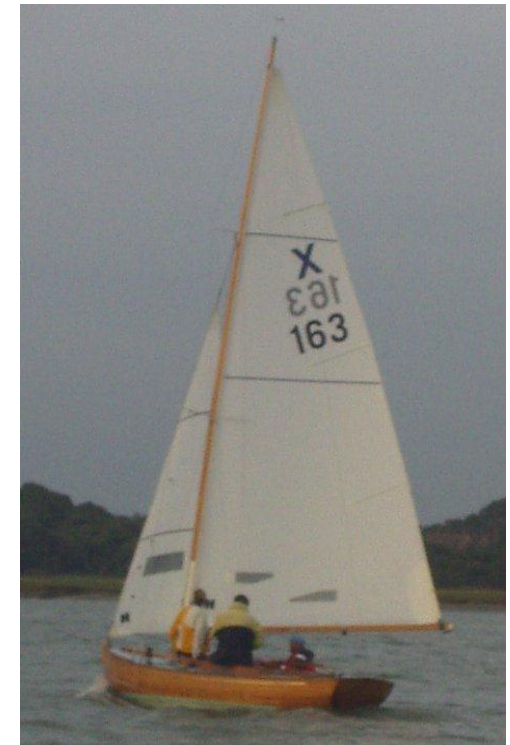



Some more examples - are they compliant?





Some more examples - are they compliant?

RRS – G1.3

(a) Except as provided in rules G1.3(d) and G1.3(e), class insignia, national letters and sail numbers shall, if possible, be wholly above an arc whose centre is the head point and whose radius is 60% of the leech length. They shall be placed at different heights on the two sides of the sail, those on the starboard side being uppermost.





Some more examples - are they compliant?





Some more examples - are they compliant?



RRS – G1.3

(a) Except as provided in rules G1.3(d) and G1.3(e), class insignia, national letters and sail numbers shall, if possible, be wholly above an arc whose centre is the head point and whose radius is 60% of the leech length. They shall be placed at different heights on the two sides of the sail, those on the starboard side being uppermost.



Questions?

For more information or to book onto a full ISAF Sail
measurement course;

Andy Wibroe – andy.wibroe@rya.org.uk