



Sail Auckland 2012

Olympic and Invited Classes

Regatta.

Incorporating:
A round of the YNZ Youth Team selection
Laser Class World selection for NZ
The 2012 Access Dinghy Class
and
The Flying Fifteen National Championships

Friday 3rd February to Tuesday 7th February 2012

Royal Akarana Yacht Club, Tamaki Drive, Orakei, Auckland, New Zealand

The Organising Authority is Sail Auckland Regatta (Inc),
in association with the Royal Akarana Yacht Club (Inc).

Sailing Instructions

1.0 Rules

1.1 The regatta will be governed by the rules as defined in *The Racing Rules of Sailing*.

1.2 The Yachting New Zealand prescriptions that will apply are shown in Attachment 1.

1.3 The Yachting New Zealand Safety regulations part 1 shall apply. Notwithstanding the dispensation granted by Yachting New Zealand, sailboard competitors shall comply with clause 1.

1.4 For Chartered or Loaned boats: In accordance with Appendix G3 a chartered or loaned boat may for this event carry national letters and sail numbers in contradiction of class rules. This changes Appendix G1.1(b).

1.5 Laser Class rule 7(a) is restricted as follows:

Only one person shall be on board whilst racing. The person shall be named on the entry form.

2.0 NOTICES TO COMPETITORS

Notices to competitors will be posted on the official notice board located inside the Royal Akarana Yacht Club.

3.0 CHANGES TO SAILING INSTRUCTIONS

Any changes to the sailing instructions will be posted before 0900hrs on the day that it will take effect, except that any change to the schedule of races will be posted by 1800hrs, or at the end of protest time, whichever is earlier, on the day before it will take effect.

4.0 SIGNALS MADE ASHORE

4.1 Signals made ashore will be displayed on the flagstaff at the northern end of the Royal Akarana Yacht Club.

4.2 When a visual signal is displayed over a course area it applies to that area only.

4.3 Flag D with one sound means "The warning signal will be made not less than 30 minutes after flag D is displayed". Boats are requested not to leave the beach until this signal is made.

4.4 When Flag AP is displayed ashore "1 minute" is replaced with "not less than 30 minutes" in the race signal AP.

5.0 FORMAT OF RACES

The format for all classes is fleet racing.

6.0 SCHEDULE OF RACES

6.1

Date	Class	Number of Races	Course Area
Saturday 4 February 2012	Laser, Radial, Finn	3	C
	RSX Men, RSX Women and Youth	3	D
	420, 470, Flying fifteen	3	B
	29er, 49er	4	B
	Skud 18, 2.4mR, Liberty, 303	3	E
Sunday 5 February 2012	Laser, Radial, Finn	3	C
	RSX Men, RSX Women and Youth	3	D
	420, 470, Flying fifteen	3	B
	29er, 49er	4	B
	Skud 18, 2.4mR, Liberty, 303	3	E
Monday 6 February 2012	Laser, Radial, Finn	3	C
	RSX Men, RSX Women and Youth	3	D
	420, 470, Flying fifteen	3	B
	29er, 49er	4	B
	Skud 18, 2.4mR, Liberty, 303	3	E
Tuesday 7 February 2012	Laser, Radial, Finn	2	C
	RSX Men, RSX Women and Youth	2	D
	420, 470	2	B
	29er, 49er	3	B
	Skud 18, 2.4mR	2	E

6.2 The warning signal for the first fleet to start on all course areas is 1100 hours each day.

6.3 Races will be sailed back to back.

6.4 Races will not be sailed ahead of schedule.

6.5 To alert boats that a race or sequence of races will begin soon, an orange flag will be displayed with one sound at least five (5) minutes before the warning signal is displayed.

- 6.6 On Tuesday 7th February 2012 no warning signal for any race will be made after 1500hrs.
On Monday 6th February no warning signal will be made for the Liberty, 303 and flying fifteen will be made after 1500 hours.
- 6.7 Prize givings will be held as soon as possible after racing on the last day. Monday 6 February for Flying Fifteen, 303 and Liberty and on Tuesday 7 February for all other classes.

7.0 CLASS FLAGS

Class	Class Flag
RS:X 9.5	Grey RS:X insignia on white and blue
RS:X 8.5	Grey RS:X insignia on white and yellow
Laser Standard	Red Laser insignia on white background
Laser Radial	Red Laser insignia on a blue background
470	Red 470 on a white background
420	Blue 420 insignia on a white background
49er	Black 49er on a yellow background
29er	Red 29er on a yellow background
Finn	Black Finn insignia on a white background
2.4mR	Blue 2.2 on a white background
Skud 18	Red Skud on a white background
Liberty	
303	
Flying Fifteen	Black Flying Fifteen insignia on a white background

8.0 RACING AREAS

Attachment 2 shows the location of the racing areas.

9.0 THE COURSES

- 9.1 The diagrams in Attachment 3 show the courses, including the approximate angles between legs, the order in which marks are to be passed, and the side on which the mark is to be left.
- 9.2 No later than the warning signal, the race committee signal boat will display the course to be sailed, the approximate compass bearing and the distance to the first mark.

10.0 MARKS

Marks are described in Attachment 3 (Courses)

11.0 THE START

- 11.1 For the RS:X classes system 1 applies.
- 11.2 The starting line will be between a staff displaying an orange flag on the starting mark at the starboard end and the port end starting mark.
- 11.3 Boats whose warning signal has not been made shall avoid the starting area during the starting sequence for other races. The starting area is defined as a rectangle 100m from the starting line in all directions.
- 11.4 A boat starting later than four (4) minutes after her starting signal will be scored Did Not Start without a hearing. This changes rule A4 and A5.

12.0 CHANGE OF THE NEXT LEG OF THE COURSE

- 12.1 To change the next leg of the course, the race committee will move the original mark (or the finishing line) to a new position.
- 12.2 Except at a gate, boats shall pass between the race committee boat signalling the change of the next leg and the nearby mark, leaving the mark to port and the race committee boat to starboard. This changes rule 28.1.

13.0 THE FINISH

The ends of the finishing line are described in Attachment 3 (Courses)

14.0 PENALTY SYSTEM

- 14.1 For the 29er, 49er, RS:X and Skud 18 classes, rule 44.1 is changed so that the Two-Turns Penalty is replaced by the One-Turn Penalty.
- 14.2 Appendix P will apply.
- 14.3 If a first penalty under Appendix P is signaled after a boat has finished, she shall be given a scoring penalty of 6 points without a hearing although her score will not be worse than the score for a DSQ.
- 14.4 An action by the Jury under Appendix P shall not be grounds for a request for redress by a competitor. The Jury may initiate a redress hearing and may give redress for an action by a member of the Jury or its designated observer under rule P1. This changes 60.1(b) and P4.

15.0 TIME LIMITS AND TARGET TIMES

15.1 Time limits and target times are as follows:

CLASS	TARGET TIME	TIME LIMIT
Laser, Laser Radial, 470, 420, Finn, 2.4mR, Skud 18, Liberty, 303, Flying Fifteen	60 minutes	90 minutes
49er,29er	35 minutes	60 minutes
RS:X	30 minutes	50 minutes

15.2 Boats failing to finish within 20 minutes after the first boat in their fleet sails the course and finishes will be scored Did Not Finish without a hearing. This changes rules 35, A4 and A5.

16.0 PROTESTS AND REQUESTS FOR REDRESS

- 16.1 For protests where only a rule of Part 2 or Rule 31, is alleged to have been broken, an arbitration hearing will be offered prior to any formal hearing. Yachting New Zealand 4.5.5 will apply. (This changes Rule 44.1).
- 16.2 Rule 44.1 is changed to permit a boat that has broken a rule of Part 2 or Rule 31 to take a penalty after racing but prior to any protest hearing. Her penalty shall be a scoring penalty as calculated in rule 44.3(c) equal to 40% of the number of entries in her fleet or 50% of the difference between her finishing position and the number of entries in her fleet, whichever is less.
- 16.3 Protest forms are available at the race office, located at the Royal Akarana Yacht Club. Protests and requests for redress or reopening shall be delivered there within the appropriate time limit.
- 16.4 For each class, the protest time limit is 60 minutes (90 minutes for Course B) after the last boat has finished the last race of the day for their class,. The same protest time limit applies to all protests by the race committee and jury to requests for redress for incidents that they observe on the water. This changes rules 61.3 and 62.2.
- 16.5 A list of boats that, under instruction 14.2 have acknowledged breaking rule 42 or have been disqualified by the jury, will be posted.
- 16.6 Notices will be posted no later than 15 minutes after the protest time limit to inform competitors of the hearings in which they are parties or named as witnesses. Hearings will be held in the Protest Room, located at the Royal Akarana Yacht Club, beginning at the time posted.
- 16.7 Notices of protests by the race committee or Jury will be posted to inform boats under rule 61.1(b).
- 16.8 Breaches of instructions 11.3,18,21,23,24, 25 and 26 will not be grounds for a protest by a boat. This changes rule 60.1(a). Penalties for these breaches may be less than disqualification if the jury so decides.
- 16.9 On the last scheduled day of racing a request for redress based on a jury decision shall be delivered no later 30 minutes after the decision was posted. This changes rule 62.2.
- 16.10 On the last day of the regatta a request for reopening of a hearing shall be delivered:
- Within the protest time limit if the party requesting reopening was informed of the decision on the previous day.
 - No later than 30 minutes after the party requesting the reopening was informed of the decision on that day.
- 16.11 Decisions of the jury will be final as provided in rule 70.5.

17.0 SCORING

17.1 The Low Scoring system will be used for all fleet races.

- 17.2 3 races are required to constitute a series.
- 17.3 When fewer than five (5) races have been completed, a boat's series score will be the total of her race scores.
- 17.4 When five (5) or more races have been completed, a boat's series score will be the total of her race scores excluding her worst score.
- 17.5 The scoring abbreviation for a penalty accepted at an arbitration hearing is ARB, and a discretionary penalty imposed is DPI.
- 17.6 The Laser Radial and 420 classes will each be sailed as single fleets and scored as such. The highest placed male will be declared winner of the men's class and the highest placed female will be declared the winner of the women's class. Second, third and subsequent places will be determined in the same manner.
- 17.7 470 men and women will be sailed together but will be scored separately.
- 17.8 The RS:X Women's Boards and the RS:X Youth Classes will sail together in one fleet but will be scored separately.

18.0 SAFETY REGULATIONS

- 18.1 All competitors except those described in 18.2 shall Check-Out and Check-In by signing-on each time they leave the shore to enter the course, and signing-off each time they come ashore from the course at the desk outside the eastern side of the clubhouse.
- 18.2 Competitors in Skud 18, 2.4m R, Liberty and 303 shall:
 - (a) check out and check in at the gated entrance to the marina before going onto the marina piers.
 - (b) wear personal flotation devices at all times while on the marina piers and while afloat.
- 18.3 A boat that retires from a race or returns to the launching area before she finished the last race of the day shall notify the Race Committee as soon as possible.

19.0 REPLACEMENT OF CREW OR EQUIPMENT

- 19.1 Substitution of competitors will not be allowed.
- 19.2 Substitution of damaged or lost equipment will not be allowed unless authorized by the jury. Requests for substitution shall be made to the jury at the first reasonable opportunity.
- 19.3 Change of sail numbers will not be allowed without prior written approval of the Race Committee.

20.0 EQUIPMENT AND MEASUREMENT CHECKS

A boat or equipment may be inspected at any time for compliance with the class rules and sailing instructions. On the water, a boat can be instructed by a race committee measurer to proceed immediately to a designated area for inspection.

21.0 ADVERTISING

Boats shall display advertising supplied by the organising authority. The organising authority will provide the stickers and instructions for their use at registration.

22.0 OFFICIAL BOATS

Official boats will display a fluro yellow flag.

23.0 SUPPORT BOATS

- 23.1 Except when participating in rescue operations, team leaders, coaches, parents and other support personnel shall stay outside areas where boats are racing from the time of the preparatory signal for the first class to start until all boats have finished or the race committee signals a postponement or abandonment of all fleets. The racing area is defined as the area inside the course and within 100 metres of any mark, lay line, starting line, finishing line or any area where any boat that is racing is sailing or may sail.
- 23.2 When the wind is less than 10 knots support boats shall not exceed 5 knots within 500 metres of the area where boats are racing.
- 23.3 When flag W (with a long sound signal) is displayed on a committee boat all support boats are requested to remain afloat and assist all sailors.
- 23.4 Support boats shall be marked with a flag displaying the countries and sail numbers of the boats that they are coaching or supporting.
- 23.5 Sufficient Personal Flotation Devices for each crew member must be carried by all support boats at all times in accordance with New Zealand Maritime Law.

24.0 TRASH DISPOSAL

Boats shall not put trash in the water. Trash may be placed aboard race committee boats.

25.0 RADIO COMMUNICATION

Except in an emergency, a boat shall neither make radio transmissions while racing nor receive radio communications not available to all boats. This restriction also applies to mobile telephones.

Attention is drawn to Auckland Regional Council Navigation Safety Bylaw (2008), in particular:

“3.13 Duty of master of a vessel under 500 gross tonnage

1. The master of a vessel under 500 gross tonnage must not allow their vessel to impede the navigation of any vessel of 500 gross tonnage or more if the vessels are in a pilotage area.

3.14 Moving prohibited zone

1. A moving prohibited zone extending to 100m astern and 100m to each side of a vessel, and continued at such width to 500m ahead, following the line of the buoyed channel when changing course, is reserved around any vessel of 500 gross tonnage

or greater, when that vessel is underway within the pilotage areas of Auckland (excluding Tamaki River) and Manukau. When navigating within a marked channel, the moving prohibited zone to the side of the vessel may be reduced to the width of the marked channel and the zone ahead of the vessel shall follow the line of the marked channel.

3. The master or person in charge of a vessel shall not navigate their vessel within the moving prohibited zone of any vessel of 500 gross tonnage or greater, within the pilotage area of Auckland (excluding Tamaki River) and Manukau, as described in Maritime Rule 90.”

Attachment 1

Yachting New Zealand (YNZ) Prescriptions that apply.

YNZ Prescription to rule 64.1, Penalties and Exoneration.

Yachting New Zealand prescribes that if a protest committee is satisfied that a breach of the Yachting New Zealand Safety Regulations occurring after the preparatory signal, is inadvertent or accidental, it may impose a penalty less than disqualification.

YNZ Prescription to rule 64.3, Decisions on Measurement Protests. Yachting New Zealand prescribes that when class rules are silent, ISAF's Equipment Rules of Sailing shall apply.

YNZ Prescription to rule 68, Damages.

Yachting New Zealand prescribes that:

1. The findings of fact, and decisions of protest committees, shall be relevant only for the purposes of the ISAF Racing Rules of Sailing.

2. All claims for damages arising from breaches of any of these rules are matters for other jurisdictions. 3. A boat that retires from a race, or accepts a penalty does not, by that action alone, admit liability.

YNZ Prescription to rule 75.2, Entering a Race.

Yachting New Zealand prescribes that, unless otherwise sanctioned by Yachting New Zealand, in National or New Zealand championships recognized by Yachting New Zealand, each crew member shall be a financial member of a club recognized by the boat's national authority. Yachting New Zealand prescribes that in National Selection Trials recognized by Yachting New Zealand, each crew member shall be a financial member of a member club of Yachting New Zealand.

YNZ Prescription to rule 77, Identification On Sails

Yachting New Zealand prescribes that where class rules are silent, boats, other than ISAF International Class boats complying fully with Appendix G, shall comply with Appendix G except they shall not be required to comply with Appendix G1.1(b).

YNZ Prescription to rule 85, Governing rules.

Yachting New Zealand prescribes that the appropriate part of the Yachting New Zealand Safety Regulations shall be deemed to be rules for all events unless dispensation is granted by Yachting New Zealand.

YNZ Prescription to rule 91, Protest Committee.

Yachting New Zealand prescribes that, except when appointed by ISAF, the organising authority shall obtain approval of an international jury from Yachting New Zealand.

The full list of YNZ Prescriptions are available from www.yachtingnz.org.nz

Attachment 2 Course Areas

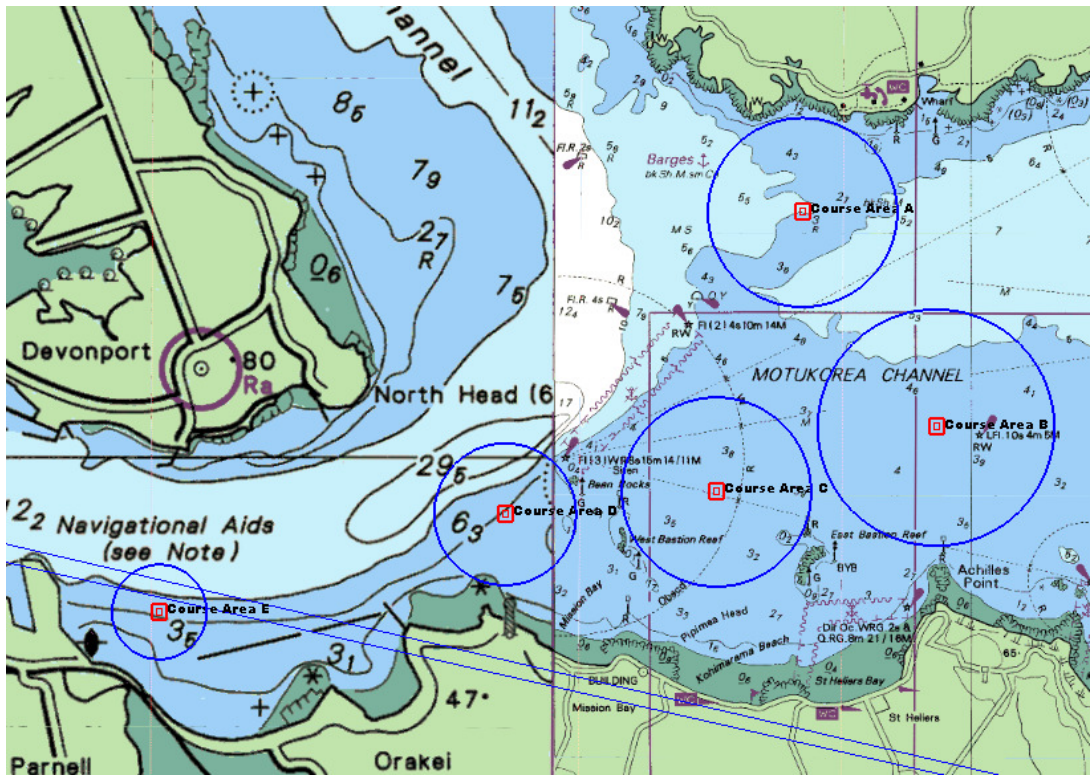

Attachment 3

Course Area A is spare and may be used by any race committee.

Course Area B – 29er, 49er – Windward Leeward

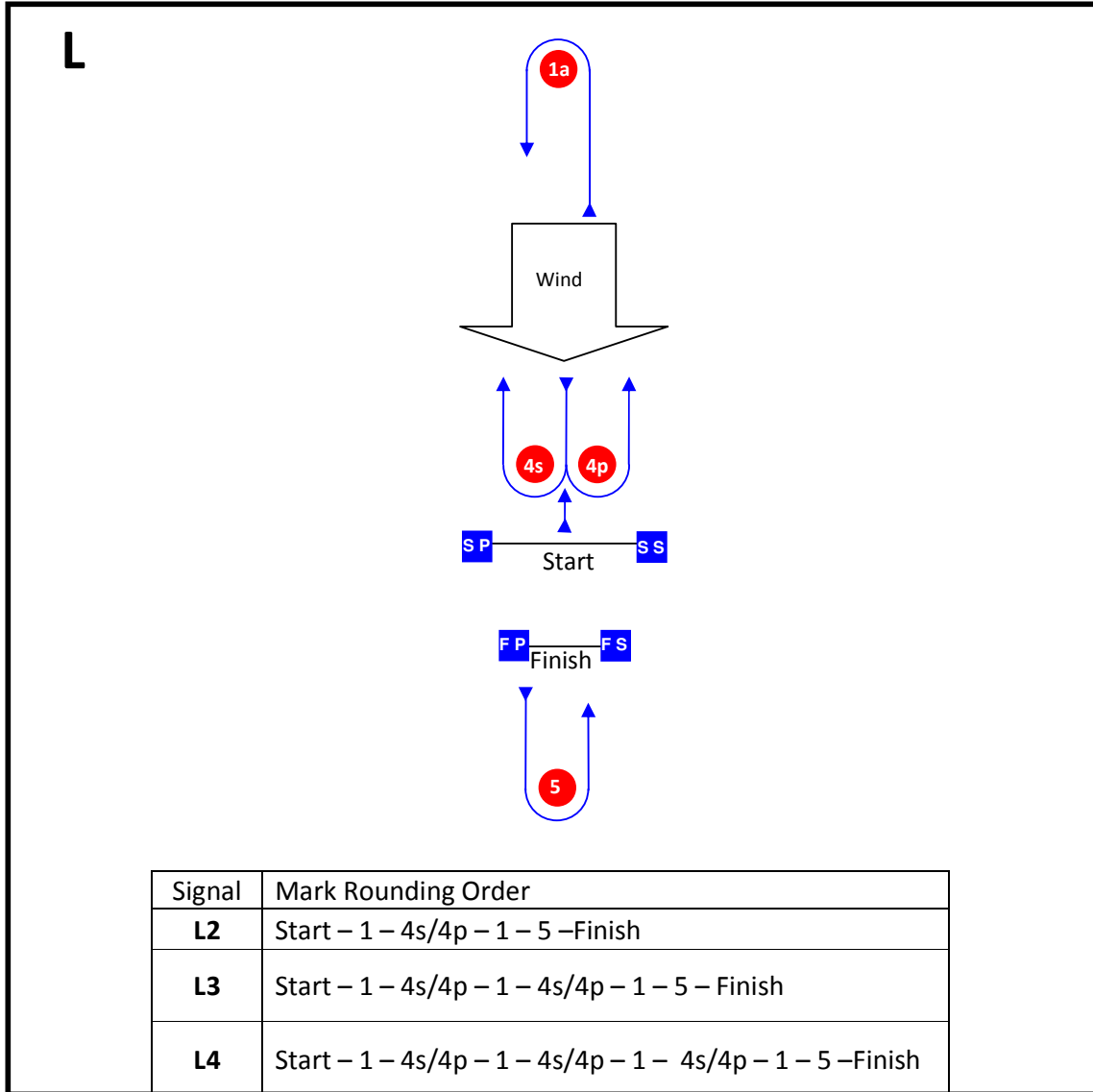

Mark	Description
1a	Black cylindrical buoy
4s 4p	Orange tetrahedral buoys
5	Yellow tetrahedral buoy
SS Starting mark starboard end	A staff displaying an orange flag on a race committee boat
SP Starting mark port end	Orange teardrop
FS Finishing mark starboard end	A staff displaying an orange flag on a race committee boat
FP Finishing mark port end	Red and black teardrop

Course Area B - 470, 420, Flying Fifteen – Trapezoid with beat to finish

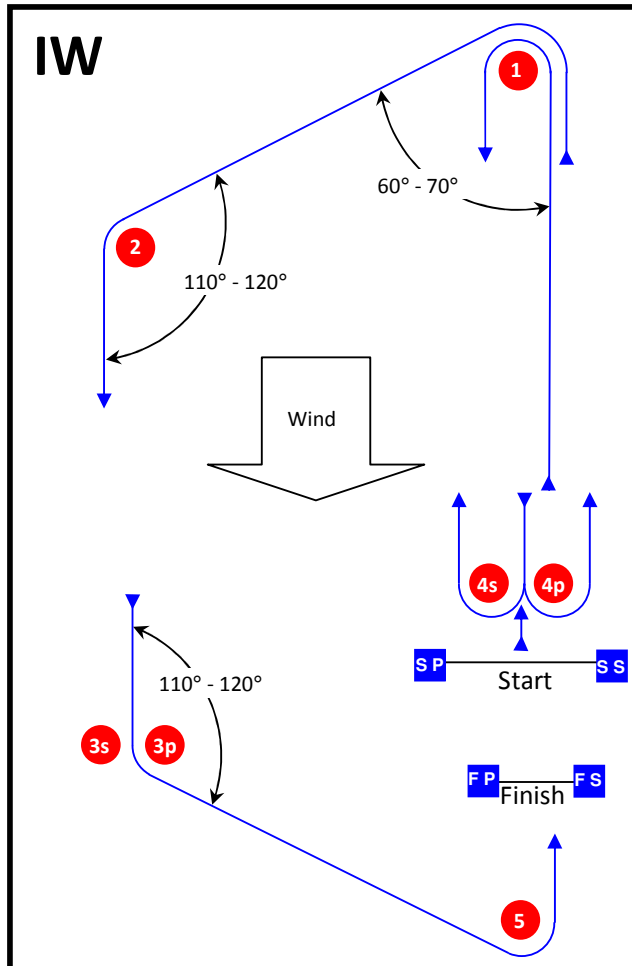

Course: Inner Trapezoid with beat to finish

Signal	Mark Rounding Order
IW1	Start – 1 – 2 – 3p – 5 – Finish
IW2	Start – 1 – 4s/4p – 1 – 2 – 3p – 5 – Finish
IW3	Start – 1 – 4s/4p – 1 – 4s/4p – 1 – 2 – 3p – 5 – Finish
IW4	Start – 1 – 4s/4p – 1 – 4s/4p – 1 – 4s/4p – 1 – 2 – 3p – 5 – Finish

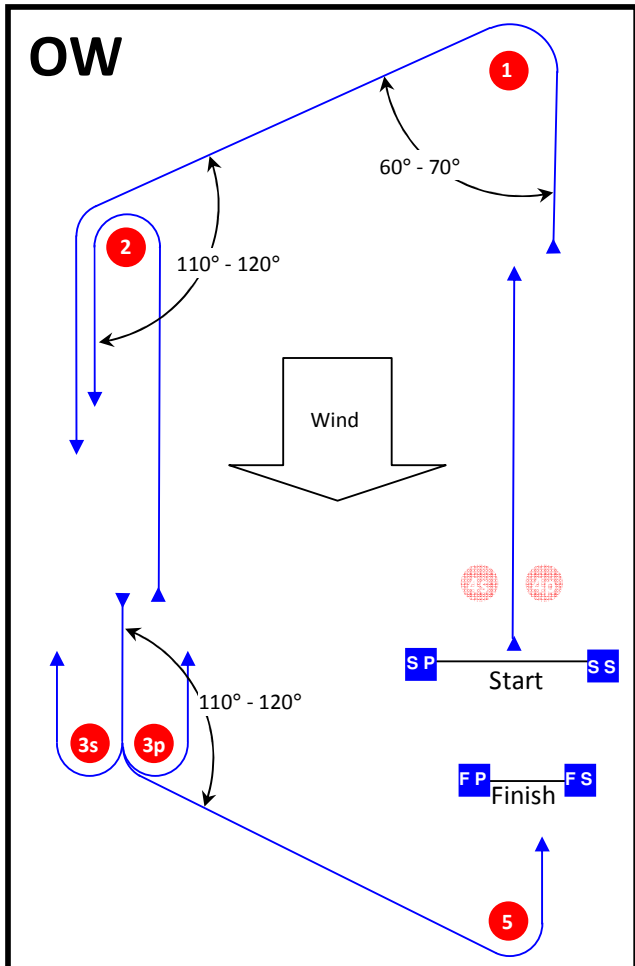

Course: Outer Trapezoid with beat to finish

Signal	Mark Rounding Order
OW2	Start – 1 – 2 – 3s/3p – 2 – 3p – 5 – Finish
OW3	Start – 1 – 2 – 3s/3p – 2 – 3s/3p – 2 – 3p – 5 – Finish
OW4	Start – 1 – 2 – 3s/3p – 2 – 3s/3p – 2 – 3s/3p – 2 – 3p – 5 – Finish

Mark	Description
1 2	Yellow tetrahedral buoys
3s 3p	Orange tetrahedral buoys
4s 4p	Orange tetrahedral buoys
5	Yellow tetrahedral buoys
SS Starting mark starboard end	A staff displaying an orange flag on a race committee boat
SP Starting mark port end	Orange teardrop
FS Finishing mark starboard end	A staff displaying an orange flag on a race committee boat
Finishing mark port end	Red and black teardrop

Course Area C - Laser, Radial and Finn – Trapezoid with beat to finish

IW

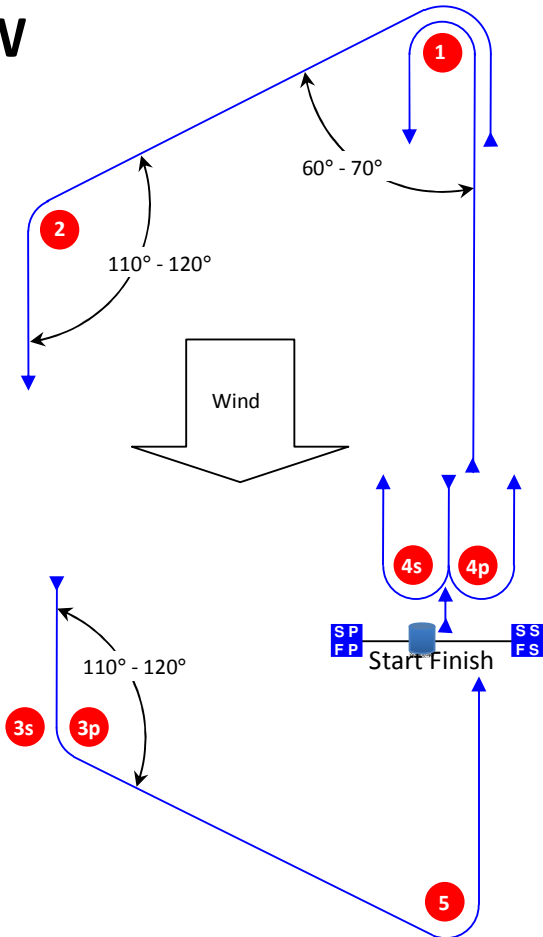

Course: Inner Trapezoid with beat to finish

Signal	Mark Rounding Order
IW1	Start – 1 – 2 – 3p – 5 – Finish
IW2	Start – 1 – 4s/4p – 1 – 2 – 3p – 5 – Finish
IW3	Start – 1 – 4s/4p – 1 – 4s/4p – 1 – 2 – 3p – 5 – Finish
IW4	Start – 1 – 4s/4p – 1 – 4s/4p – 1 – 4s/4p – 1 – 2 – 3p – 5 – Finish

OW

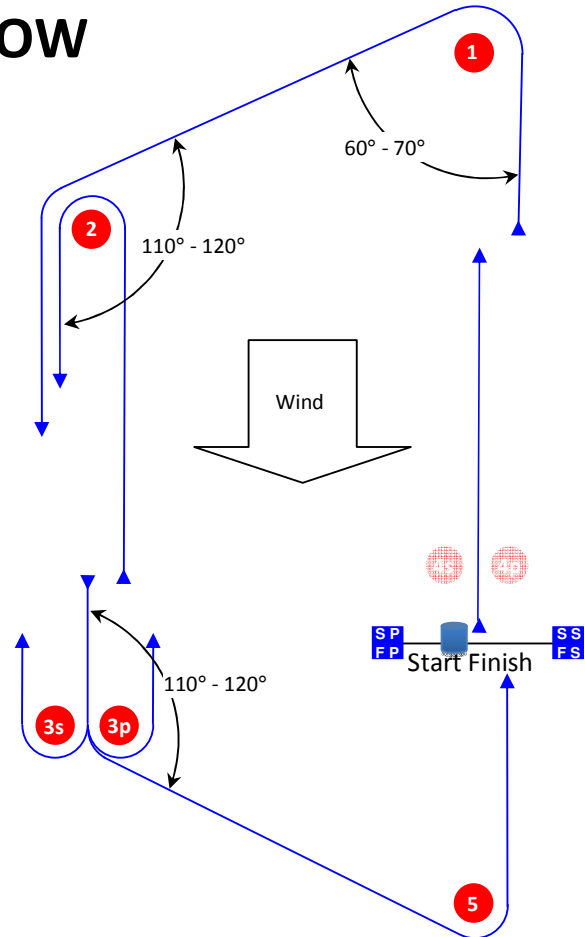

Course: Outer Trapezoid with beat to finish

Signal	Mark Rounding Order
OW2	Start – 1 – 2 – 3s/3p – 2 – 3p – 5 – Finish
OW3	Start – 1 – 2 – 3s/3p – 2 – 3s/3p – 2 – 3p – 5 – Finish
OW4	Start – 1 – 2 – 3s/3p – 2 – 3s/3p – 2 – 3s/3p – 2 – 3p – 5 – Finish

Mark	Description
1 2	Large Orange Cylindrical buoys
3s 3p	Orange Cylindrical buoys
4s 4p	Orange Cylindrical buoys
5	Large Orange Cylindrical buoys
SS Starting mark starboard end	A staff displaying an orange flag on a race committee boat
SP Starting mark port end	A staff displaying an orange flag on a race committee boat
FS Finishing mark starboard end	A staff displaying an orange flag on a race committee boat
Finishing mark port end	A staff displaying an orange flag on a race committee boat
Starting mark port end FINN	Red teardrop buoy

Course Area D - RS:X – Windward Leeward

L

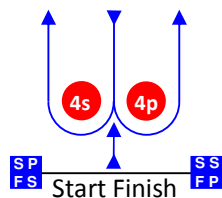
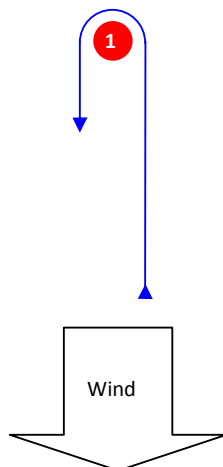

Course: Leeward finish

Signal	Mark Rounding Order
L2	Start – 1 – 4s/4p – 1 – Finish
L3	Start – 1 – 4s/4p – 1 – 4s/4p – 1 – Finish
L4	Start – 1 – 4s/4p – 1 – 4s/4p – 1 – 4s/4p – 1 – Finish

Mark	Description
1	Orange Cylindrical buoy
4s 4p	Orange Cylindrical buoy
SS Starting mark starboard end	A staff displaying an orange flag on a race committee boat
SP Starting mark port end	Red Spherical buoy
FS Finishing mark starboard end	Red Spherical Buoy
FP Finishing mark port end	A staff displaying an orange flag on a race committee boat

Course Area D - RS:X - Windward Leeward with Slalom

LS

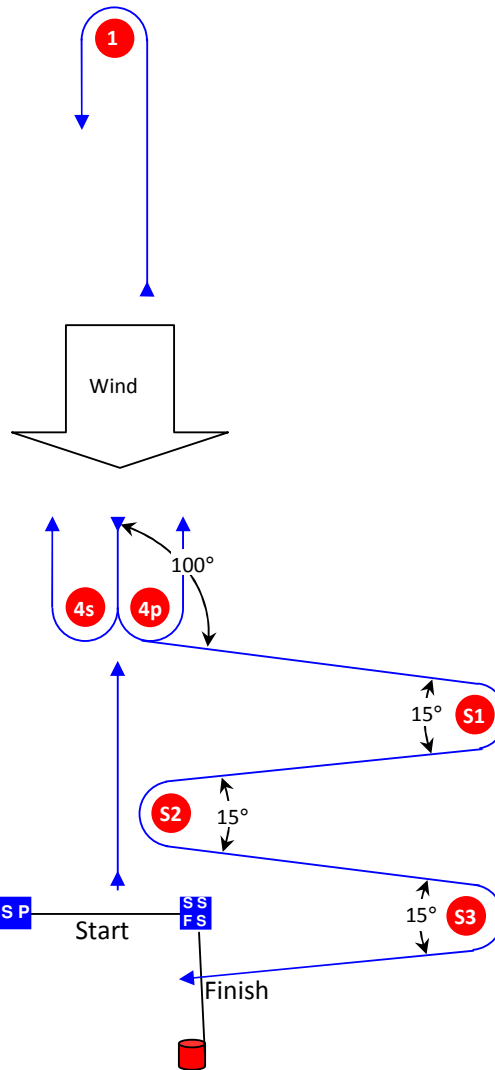

Course: Windward Leeward slalom finish

Signal	Mark Rounding Order
LS2	Start – 1 – 4s/4p – 1 – 4p – S1 – S2 – S3 – Finish
LS3	Start – 1 – 4s/4p – 1 – 4s/4p – 1 – 4p – S1 – S2 – S3 – Finish
LS4	Start – 1 – 4s/4p – 1 – 4s/4p – 1 – 4s/4p – 1 – 4p – S1 – S2 – S3 – Finish

Mark	Description
1	Orange Cylindrical buoy
4s 4p	Orange Cylindrical buoys
S1 S2 S3	Yellow Cylindrical buoys
SS Starting mark starboard end	A staff displaying an orange flag on a race committee boat
SP Starting mark port end	Red spherical buoy
FS Finishing mark starboard end	A staff displaying an orange flag on a race committee boat
Finishing mark port end	Yellow tetrahedral buoy

Course Area E – Scud 18, 2.4R M, 303, Liberty - Trapezoid

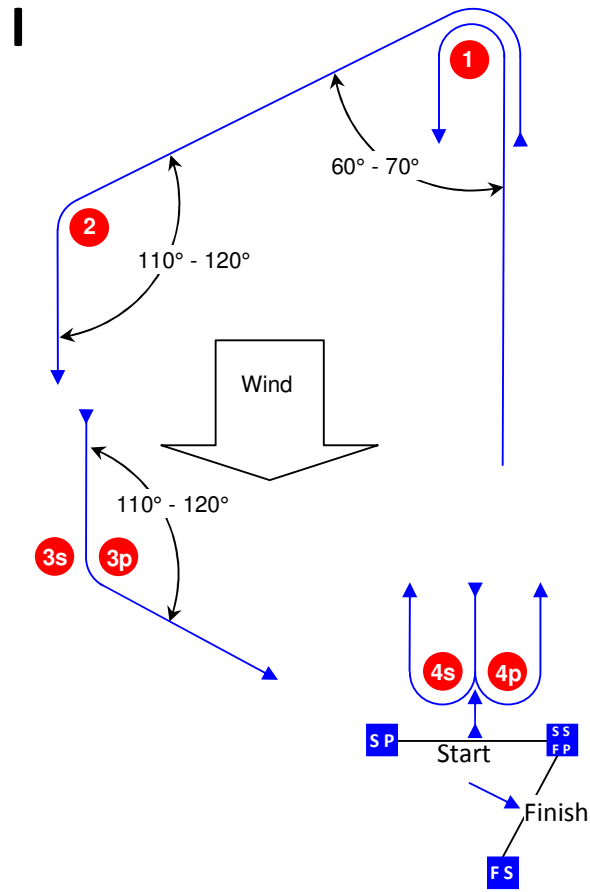

Course: Inner Trapezoid

Signal	Mark Rounding Order
I2	Start – 1 – 4s/4p – 1 – 2 – 3p – Finish
I3	Start – 1 – 4s/4p – 1 – 4s/4p – 1 – 2 – 3p – Finish
I4	Start – 1 – 4s/4p – 1 – 4s/4p – 1 – 4s/4p – 1 – 2 – 3p – Finish

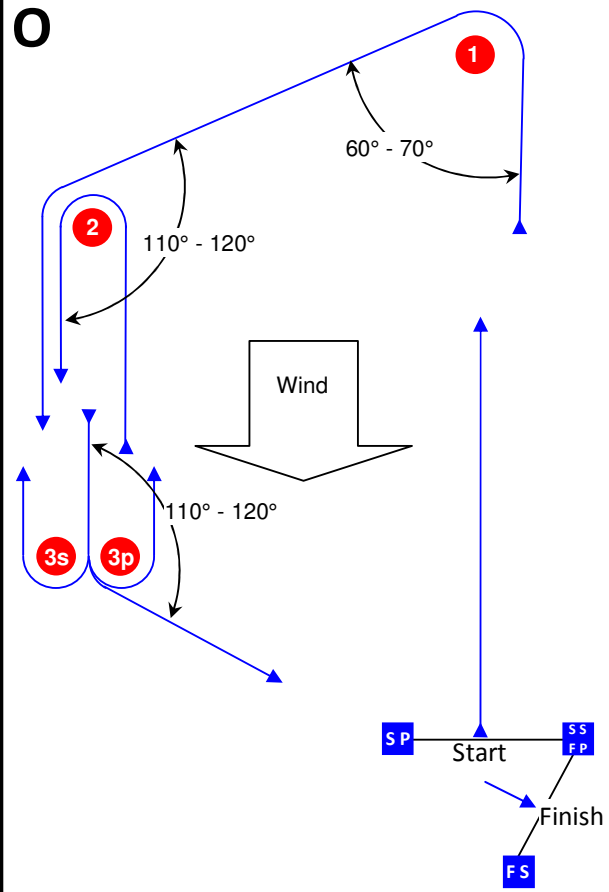

Course: Outer Trapezoid

Signal	Mark Rounding Order
O2	Start – 1 – 2 – 3s/3p – 2 – 3p – Finish
O3	Start – 1 – 2 – 3s/3p – 2 – 3s/3p – 2 – 3p – Finish
O4	Start – 1 – 2 – 3s/3p – 2 – 3s/3p – 2 – 3s/3p – 2 – 3p – Finish

Mark	Description
1 2	Red cylindrical buoys
3s 3p	Red tetrahedral buoys
4s 4p	Red tetrahedral buoys
SS	Starting mark starboard end A staff displaying an orange flag on a race committee boat
SP	Starting mark port end Orange teardrop buoy
FS	Finishing mark starboard end Red and Black teardrop
FP	Finishing mark port end A staff displaying an orange flag on a race committee boat