



**MEETING DATES:  
NOVEMBER 23-28**

**EXHIBIT DATES:  
NOVEMBER 25-28**



# **EXHIBITORS' PROSPECTUS AND SPONSORSHIP & ADVERTISING BROCHURE**



**THE LARGEST DENTAL MEETING/EXHIBITION/CONGRESS IN THE UNITED STATES**

# GREATER NEW YORK DENTAL MEETING™

## 2018

### MEETING DATES

Friday, November 23 -  
Wednesday, November 28

### EXHIBIT DATES

Sunday, November 25 -  
Wednesday, November 28

held at the

JACOB K. JAVITS CONVENTION CENTER OF NEW YORK

**Lauro Medrano-Saldaña, D.D.S.**  
General Chairman

**Robert R. Edwab, D.D.S., M.B.A.**  
Executive Director

**Ms. Carla M. Borg**  
Exhibits Manager

**Ms. Dana A. Soltis**  
Sponsorship & Advertising Manager

Co-Sponsored by the  
**SECOND DISTRICT DENTAL SOCIETY**  
and the  
**NEW YORK COUNTY DENTAL SOCIETY**  
of the State of New York



THE FOLLOWING RULES & REGULATIONS GOVERN EXHIBITS AT THE  
94<sup>th</sup> ANNUAL GREATER NEW YORK DENTAL MEETING. PLEASE READ CAREFULLY.

#### EXECUTIVE OFFICE:

200 West 41<sup>st</sup> Street - Suite 800, New York, NY 10036-7203, USA

Telephone (212) 398-6922 / Fax (212) 398-6934

E-mail: [carla@gnydm.com](mailto:carla@gnydm.com) / Website: [www.gnydm.com](http://www.gnydm.com)

# NEW YORK CITY

## WHERE THE WORLD DOES BUSINESS

The Largest Dental Meeting/Exhibition/Congress in the United States

Dear Potential Exhibitor:

The Organization Committee of the Greater New York Dental Meeting invites you to exhibit at its 2018 Meeting.

Our 2017 Meeting was a huge success. We are delighted to inform you that even with challenges that other events felt, we once again set record high numbers. Total registration in 2017 was **52,733**. Included were **18,998** dentists from all **50** states and **9,026** international attendees from **151** countries of which **5,803** were also dentists. Our exhibit floor contained over **700** companies in **1600** booths. With a total registration of **52,733** and no comparable exhibit floor of its size in the U.S., it continues to solidify the position of the Greater New York Dental Meeting as the largest Dental Convention and Exposition in the United States and as the premier buying location for professionals in the Domestic and International Dental community.

Enclosed you will find the 2018 Exhibitor Prospectus containing an Application/Contract for exhibit space, floor plan, and Rules and Regulations. Kindly complete and sign the Application/Contract, return original copy to us and retain a copy for your records. Please note that a deposit of \$1000.00 per 10 x 10 booth space must accompany your signed Application/Contract. Application/Contract received without a deposit will NOT be processed and a booth assignment will not be made. Exhibitors from the 2017 Meeting will be given preference providing their Applications/Contracts are received prior to March 13. After this date, booths will be allocated on a first-come, first-served basis and your priority status will no longer be considered.

Exhibitors who are interested in advertising, banners, signage and/or sponsoring specific events or programs can contact our Sponsorship & Advertising Manager, Dana Soltis at [Dana@gnydm.com](mailto:Dana@gnydm.com). The Sponsorship/Advertising Brochure can be accessed on our website, [www.gnydm.com](http://www.gnydm.com).

Booth space and sponsorships are unique opportunities that you will want to consider. As an exhibiting company, you are more than an exhibitor; you are our business partner and we will try and maximize your investment. We trust that you will join us in what we expect to be another exciting and rewarding Meeting. If you have any additional questions, please contact us at anytime.

Sincerely,



Carla M. Borg  
Exhibits Manager



Lauro Medrano-Saldana, D.D.S.  
General Chairman



Robert R. Edwab, D.D.S., M.B.A.  
Executive Director

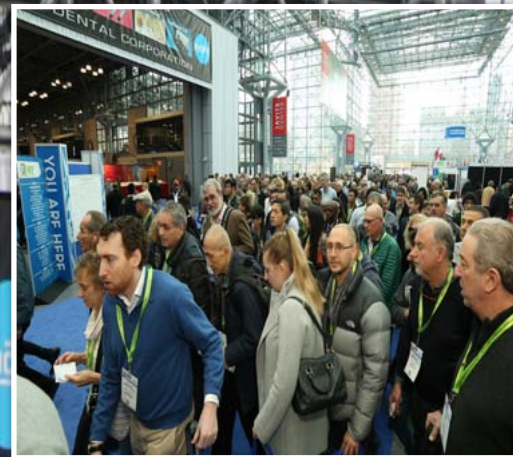

# Table of Contents

## EXHIBITORS' PROSPECTUS

Application & Payment for Space .....	5
Cancellation or Reduction of Space .....	6
Charges for Space .....	5
Checklist of Important Dates .....	19
Conference Rooms .....	5
Contracts .....	14-15
Exhibit Dates & Hours .....	6
Exhibit Dismantling .....	7
Exhibit Set-up .....	6
Exhibit Space Assignment .....	5
Exhibitor's Calendar .....	18
Floor Plan .....	16-17
Special Programs .....	18

## SPONSORSHIP & ADVERTISING

Sponsorship Opportunities .....	20-24
Onsite Newspaper .....	26
Educational Program Support .....	25
Publication Advertising .....	27
Advertising Contract .....	28
Sponsorship Contract .....	29
Newspaper Contract .....	30



# Rules and Regulations

## 1. APPLICATION/CONTRACT FOR SPACE

An Application/Contract for exhibit space at its 2018 Meeting must be made in writing to the Greater New York Dental Meeting Organization Committee (the "Committee"), and must be accompanied by a deposit of \$1,000.00 for each 10 x 10 booth space requested prior to July 28, 2018 or full payment thereafter. No Application/Contract will be considered unless accompanied by said payment. The Exhibitor's properly signed Application/Contract, together with Certificate of Insurance and the appropriate payment must be returned to:

Ms. Carla Borg, Exhibits Manager  
Greater New York Dental Meeting  
200 West 41st Street- Suite 800  
New York, NY 10036-7203

Exhibit space shall be assigned solely by the Committee. The Committee at its discretion, accepts or rejects applications for booth space.

Applicants are advised that final confirmation of exhibit space may be delayed due to the volume of applications received at the time of submission and deposit of the applicant's check should not be construed as confirmation of acceptance. Until the applicant receives final written acceptance or denial of exhibit space, any funds expended for the development or construction of an exhibit booth are done so at the applicant's own risk.

The Committee does not guarantee that it will be able to assign the space requested. Previous booth location will be considered but cannot be guaranteed.

In addition, the Committee cannot guarantee that competitors will not be placed near each other, but will endeavor not to do so.

The priority mailing deadline is March 13, 2018. After this date, booths will be allocated on a first-come, first-assigned basis. Previous Exhibitors will receive preference providing their Application/Contract is received prior to March 13.

Assignments of space not rejected in writing by the Exhibitor within 14 days after notification of space assignment will be presumed to be accepted by the Exhibitor.

In order to be included in the Program & Exhibit Guide classified listing, the Exhibitor must submit its product classifications together with the Application/Contract when that form is due, and no later than June 15, 2018.

The number of product listings allowed is based on the number of booths rented, and this information is detailed on the classification listing form part of the Application/Contract. Enter correct product codes on the form as these codes are used for data entry in the production of the Program & Exhibit Guide.

## 2. CHARGES FOR SPACE

### EXHIBIT BOOTHS

8 X 10	SPACE .....	\$3,455
8 X 10	CORNER SPACE .....	\$3,945
10 X 10	SPACE .....	\$4,325
10 X 10	CORNER SPACE .....	\$4,950
10 X 15	SPACE .....	\$6,475

The price of the booth includes the following: pipe and drape 8' high (2.5m) in the rear and 36" (91.44cm) on each side; a single-line identification sign with Exhibiting Company name and booth number; 12 Exhibitor badges per 10 x 10 booth; Company name, address, phone, website, email address, fax and product classification in our Program & Exhibit Guide (deadline June 15, 2018). Contracts submitted after June 15, will not be listed in the Program & Exhibit Guide. They will be listed in the on-site publication if contracted and proper information submitted prior to November 15, 2018.

Exhibitors requesting island space must rent additional space to create an island configuration. For example, if the Exhibitor requests a 20' x 30' island (six booths), a 20' x 40' space (eight booths) will be needed to create the island.

The minimum size for a peninsula booth configuration is 20' x 20'. This policy is due to the limited number of corner booths. Exhibitors requesting a peninsula configuration must adhere to the following policy: no solid exhibition construction will be permitted to exceed 48 inches in height unless it is at least 5' from the nearest aisle. This means that peninsula booths cannot have a 20' back wall. (Only 10')

### PAVILIONS

Island space with widths greater than 20' (which includes renting aisle space), may be obtained with written approval of the Committee. In designated areas of the Exhibit Hall aisle space may be rented and become a contiguous part of your Exhibit. Minimum size for Pavilion configuration is 20 x 50. The Exhibitor will have to purchase a 30 x 50 space in order to create a 20 x 50 Pavilion. No blocking of the aisle is permitted.

### CONFERENCE ROOMS

Conference rooms are only available to exhibit booth lessees. They are located on the north perimeter of the Exhibit Hall and can be used for a variety of purposes: sales discussions with customers, staff lounges, staff meeting rooms or storage. Assignments are on a first-come basis. All refreshments utilized in conference rooms must be ordered through Centerplate. 10' X 10' conference rooms are available at a

cost of \$2,085.00 each. Multiple rooms can be combined into a single space. Each conference room has 8 foot high hardwall construction, two door keys, a sign and carpet. Customization, additional lighting, furnishings and upgrade of conference rooms are available through Freeman.

### DAILY CONFERENCE ROOMS

Each room includes: hardwall configuration, carpeting, keys, table and chairs.

10 X 10 .....	\$950.00/day
10 X 20 .....	\$1,480.00/day

### EXECUTIVE SUITES

Four 11 x 30 suites overlooking the exhibit floor are available for \$7,720.00 each for the entire Meeting. Each suite provides the Exhibitor with carpeting, private bathroom and kitchen facilities, conference table and 8 chairs set up. This is an ideal meeting room for busy executives, private meetings with customers and/or a staff lounge. Food service is available through Centerplate.

## 3. TERMS OF PAYMENT

The Committee requires a deposit of \$1,000.00 for each booth space or conference room with the Application/Contract. The entire balance must be received by the Committee on or before August 1, 2018. An Application/Contract made after August 1, 2018, must be accompanied by full payment. An Application/Contract received after October 30, 2018, must be accompanied by full payment in the form of certified check or cash. In the event that the Exhibitor shall fail to make payment of any balance on or prior to said due date, then and in addition to any and all other rights and remedies thereby available to it, the Committee may, at its option, terminate the contract, retain as liquidated damages any payment made thereunder, and assign the space specified therein to any third party or parties or use the same for such other purposes, if any, as it may deem appropriate, all without notice and without further liability to the Exhibitor. Each payment by the Exhibitor shall be made by check payable to the Greater New York Dental Meeting and such payment shall not be deemed made until the check clears the bank on which it is drawn. Each check and contract shall be delivered to Ms. Carla Borg at the Greater New York Dental Meeting, 200 West 41st Street - Suite 800, New York, NY 10036-7203. All checks shall be drawn upon and payable in U.S. dollars only at banks located and authorized to transact business in the United States. Third party checks are not accepted. A \$40.00 bank charge must be paid for each overseas bank draft submitted. A charge of \$40.00 will be assessed for any check returned from bank unpaid for any reason.

# Rules and Regulations

## 4. CANCELLATION

If the Exhibitor shall seek to cancel its contract, written notice thereof shall be given to the Committee by registered or certified mail. If such notice is received by the Committee prior to June 1, 2018, the Exhibitor shall be entitled to a refund of its entire payment. If such notice is received between June 2 and July 31, 2018 the Exhibitor shall be entitled to a refund of money paid in excess of the \$1,000.00 deposit for each space requested. If such notice is received on or after August 1, 2018, the Exhibitor shall not be entitled to any refund whatsoever. An Exhibitor making Application/Contract after August 1, 2018, will have fourteen (14) days following assignment of space to cancel its contract and receive a refund of its entire payment. Upon receipt of any such notice of cancellation, the Committee may assign the Exhibitor's space to any third party or parties or use the same for such other purposes as it may deem necessary, all without notice and without further liability to the Exhibitor.

If the Exhibitor shall seek to cancel a conference room and/or executive suite, written notice is required. If such notice is received by the Committee prior to June 1, 2018, the Exhibitor shall be entitled to a refund of its entire payment. If notice is received after June 1, Exhibitor is entitled to a refund of money paid in excess of \$1,000. After August 1, Exhibitor is not entitled to any refund of monies paid.

## 5. THE EXHIBITION

The exhibition shall be held at the Jacob K. Javits Convention Center of New York, operated by the New York Convention Center Operating Corporation (the "Center"). The Exhibitor shall be subject to the applicable rules and requirements of the Center, in addition to the obligation to comply with the provisions of the contract with the Committee.

The following shall be the exhibition hours during the Meeting, and the Exhibitor shall keep its exhibit open and on display and properly manned throughout all such hours, but none others:

Sunday, November 25	9:30 A.M.-5:30 P.M.
Monday, November 26	9:30 A.M.-5:30 P.M.
Tuesday, November 27	9:30 A.M.-5:30 P.M.
Wednesday, November 28	9:30 A.M.-5:00 P.M.

Failure of the Exhibitor to comply with the provisions of this Paragraph "5" shall constitute a substantial violation of these Rules and Regulations and of the contract of which it forms a part.

## 6. SETTING UP EXHIBITS

Subject to the conditions hereinafter stated, exhibit space will be available for the setting up of displays at 10:00 A.M. on Friday, November 23, 2018. The Exhibitor must have all packing cases, crates and containers emptied and

labeled and ready for pick up and storage by 10:00 A.M. on Saturday, November 24, 2018, and the entire exhibit, with all displays, must be complete and ready for inspection and exhibition by 5:00 P.M. on Saturday, November 24, 2018. In the event that the Exhibitor shall fail to carry out and complete such setting up within the time and in the manner thus specified, the Committee may, at its option, remove the Exhibitor's property from the exhibition area and store or otherwise dispose of the same in such fashion as it may deem necessary, but at the sole cost and expense of the Exhibitor, and such failure on the Exhibitor's part shall constitute a substantial violation of these Rules and Regulations.

At no time and under no circumstances, shall the Exhibitor keep or store any packing cases, crates or containers or any other packing materials at, under or behind its displays or in or at its exhibit.

## 7. FAILURE TO OCCUPY SPACE

Any space not claimed and/or occupied one hour after the show opening may be resold or reassigned without refund or credit.

## 8. JAVITS CENTER SERVICES

The Center has the exclusive right to install and provide telephone, telecommunication, water, waste water, plumbing and electrical services. The Javits Center also has the exclusive right to supply the labor utilized within the Center to perform any of the services described in the Javits Center Work Rules set forth in Paragraph "9" hereof, and neither Exhibitor nor any contractor employed by Exhibitor, nor any vendors supplying goods or services to Exhibitor shall utilize any other labor to perform such services. Such labor shall be provided on written order at the established rates of the Center for such services and shall be utilized pursuant to the Javits Center Work Rules as set forth in Paragraph "9" hereof.

Exhibitor must include the Javits Center Work Rules in any contract or agreement between Exhibitor and any contractor or vendor and Exhibitor must require compliance with said rules by any contractor, vendor and its agents, representatives, employees and subcontractors. Exhibitor is responsible for such compliance, and failure by a contractor, vendor or its agents, representatives, employees or subcontractors to comply with this Paragraph or the Javits Center Work Rules set forth in Paragraph "9" hereof shall be a substantial violation of these Rules and Regulations. The Center has the right to approve all prices charged by any contractor for services described in the Javits Center Work Rules.

With regard to services not mentioned in Paragraph "8" or Paragraph "9" hereof, Exhibitor may contract with persons approved by the Committee and the Center for services not available from the Center.

All work or labor involved in or connected with the loading, unloading and moving Exhibitors' freight materials and machinery must be performed in accordance with the Javits Center Work Rules set forth in Paragraph "9" hereof.

All work or labor involved in or connected with the construction, erection, installation, maintenance or dismantling of exhibits, including, without limitation, all displays, backgrounds, booths, appointments and floor or base coverings, and any and all parts or portions thereof, are and shall be within the jurisdiction of the International Brotherhood of Carpenters and Joiners, New York District Council, which also has and shall have jurisdiction over the uncrating and recrating of all exhibit materials, equipment and other property, and all work or labor requiring the use of bolts, screws or nail fasteners, all work or labor involved in or connected with tying, hanging, nailing or taping of flags, banners, drapes or signs, including but not limited to wall draperies, table skirting, booth equipment draperies, flags, bunting or party decorations, all work or labor involved in or connected with the laying of tile, carpet or rugs, skidding, reskidding and turntables, all work or labor regarding handling, distributing or delivering of furniture, carpeting, rugs, modular interlocking booth systems, other standardized equipment or other equipment owned or leased by Exhibitor must be performed in accordance with the Javits Center Work Rules set forth in Paragraph "9" hereof.

Notwithstanding the Javits Center Work Rules, hand-carry items can be brought into the Center through the front of the building (eastside - 11th Avenue only), as long as parking regulations are obeyed. Parking locations will be assigned by the Event Manager. Parking is limited to vehicles no larger than a Ford Econoline van. Vehicles must be attended by a licensed driver at all times. Exhibitors may use nothing larger than a two-wheeled baggage cart (plastic or rubber wheels only) to move their items.

Notwithstanding the Javits Center Work Rules, "Pop-up" displays equal or less than 10 feet in length, capable of being carried by hand by one person may be brought into the Center. Exhibitors moving items must use doors and routes designated by the Event Manager. Individuals moving these items must be employees of Exhibitor and must carry identification and be wearing either an Exhibitor or installation badge to verify that fact.

Exhibitors may unpack, pack and arrange their merchandise and products in their exhibit. Exhibitors may install or dismantle their exhibit and lay carpet in their exhibit as long as the booth size is 100 square feet or less and the work can be done without tools. Those performing the work must be employees of the Exhibitor and must carry identification and

# Rules and Regulations

be wearing either an Exhibitor or installation badge to verify that fact.

Advance arrangements for all such union work or Center labor shall be made by the Exhibitor with the Official Full Service Contractor, to wit, Freeman Warehouse, 1 Railroad Place, Maspeth, NY 11378, and if further information should be sought as to such union work or Center labor, the Exhibitor may telephone said firm at (201) 998-6444.

## 9. JAVITS CENTER WORK RULES

Contractor and Exhibitor must hire Javits Center labor to perform the following tasks:

(a) Loading, unloading and moving Exhibitor freight materials and machinery, loading and unloading decorating contractors' equipment to and from a marshalling point on the exhibit show floor, but Exhibitor hand-carry items are exempted from this requirement. **No 4-wheeled carts permitted.**

(b) Crating and re-crating, and all work involved in the erection and dismantling of exhibits, displays, backgrounds and booths; all work requiring the use of bolts and screws or nail fasteners; tying, hanging or nailing, taping of flags, banners, signs, tile and rug-laying, skidding and re-skidding and turntables; handling and delivery of furniture, carpeting, modular interlocking booth systems and other contractor owned and leased equipment; pad wrapping, protection work, ramp protection; and installing draperies, including but not limited to wall draperies, table skirting, booth equipment draperies, flag and bunting and party decorations, but "Pop-up" booths are exempted from this requirement.

Contractors are permitted to use their own personnel as managers and supervisors of the labor described above, provided that they have completed a questionnaire and have been approved by the Center, that they are performing only legitimate managerial tasks, and that the company maintains a reasonable ratio of managers and supervisors to labor. Violation of any of these conditions shall result in a revocation not only of the supervising employee's authorization, but also of the contractor's authorization to conduct business at the Center.

Employees of the Center, contractors, employees of contractors, Exhibitors and employees of Exhibitors are prohibited from giving to or accepting from anyone, directly or indirectly, any gratuities or anything else for any reason in the Center or in relation to any work performed in the Center.

## 10. USE OF EXHIBITOR APPOINTED CONTRACTOR

If an Exhibitor plans to use a contractor other than Freeman for installation and dismantling

of its exhibit, they must complete an Exhibitor Appointed Contractor form. Notice of this intent must be sent to the Greater New York Dental Meeting and Freeman by August 28, 2018. Exhibitors who have not sent notification by this date must use the Official Full Service Contractor. The Contractor, and any of its employees or agents must comply with the Javits Center Work Rules set forth in Paragraph "9" hereof. In addition, the selected Contractor must complete a "Javits Center questionnaire" and provide the Greater New York Dental Meeting with the following: a copy of its license to operate in the State of New York and the Jacob K. Javits Convention Center, a list of all personnel to be conducting services for the Exhibitor, and an original certificate of insurance listing the Greater New York Dental Meeting, the New York Convention Center Operating Corporation, the State of New York, the New York Convention Center Development Corporation, the Empire State Development Corporation, the Triborough Bridge and Tunnel Authority and Freeman and its employees as additional named insureds, as set forth in the indemnification and insurance provisions in the contract for exhibit space. The Exhibitor is responsible for supplying the appointed Contractor with the necessary information included in the exhibit packet. The employees of the Appointed Contractor must report to the registration area to pick up their badges prior to commencing work. The Exhibitor assumes liability for the Exhibitor Appointed Contractor and his employees. Solicitation for business by any Exhibitor Appointed Contractor on the exhibit floor is expressly forbidden. Any Exhibitor Appointed Contractor not meeting the above requirements and deadline will not be allowed to erect or dismantle said exhibits.

## 11. DISMANTLING OF EXHIBITS

Exhibit Hall 3A Exhibitors must be packed by 11:00 A.M. Thursday, November 29, 2018 to facilitate moving out by 9:00 P.M. that evening. All transportation arrangements for these Exhibitors must be made with Freeman Company by 4:00 P.M. on November 29, 2018 or will be subject to re-routing. (Subject to change)

Exhibit Halls 3E, 3B and 3D must be packed by 9:00 P.M. Thursday, November 29, 2018 and transportation arrangements must be made by 10:00 A.M. Friday, November 30, 2018. Please contact Exhibits Manager or the Official Full Service Contractor for more details. (Subject to change)

Since the Official Full Service Contractor for the Meeting will, beginning at 5:00 P.M. on Wednesday, November 28, 2018, arrange with Javits Center labor to remove all aisle carpeting and to return from storage to the Exhibitor's booth for packing its cases, crates and containers, the Exhibitor shall arrange with the Official Full Service Contractor or their Exhibitor Appointed Contractor for Javits Center

labor, at its expense, to dismantle and pack its entire exhibit and all displays and materials included therein and shall arrange to have the Official Full Service Contractor using Convention Center labor remove the same, together with any and all other property belonging to the Exhibitor or for which it is responsible, from the Center.

If the Exhibitor uses an automobile, station wagon, small van or like vehicle for such removal, it may do so on Wednesday evening, November 28, 2018, by checking into the freight service desk starting at 4:00 P.M. and by packing its entire exhibit, with all its displays, materials and other property, in such vehicle.

Such removal shall be accomplished between 6:30 P.M. and 9:30 P.M. that day, namely, Wednesday, November 28, 2018, in the same order in which the check-in took place. During those hours the Official Full Service Contractor will withhold the loading of trucks, and will not commence such loading until about 8:00 A.M. on Thursday, November 29, 2018.

In the event that the Exhibitor shall fail to effect removal of all its property within the time and in the manner specified above, such removal may be effected by the Committee or its designee, and the Exhibitor's property may be stored or otherwise disposed of by such means, at such times and under such circumstances as the Committee may deem appropriate, but at the sole cost and expense of the Exhibitor. The Exhibitor releases the Committee or its designee from any claim for damages resulting from such storage or disposal.

## 12. EXHIBIT LIMITATIONS

All exhibits must be constructed and set to the rear of the booth space. No exhibit can be set forward as to block, cover or screen any other exhibit. In addition, the Exhibitor shall conform to and comply with the following requirements in the installation, maintenance and display of its exhibit. It is required that plans for all island/peninsula exhibits be submitted to the Greater New York Dental Meeting for review/approval at least 90 days prior to Meeting dates. If not received, exhibitor will be responsible for any onsite charges for changes required that do not adhere to the regulations of the Meeting:

(a) No exhibit shall cover, screen or obscure any exit or other signs, or interfere with access to exits, fire-fighting equipment, first aid facilities or emergency or other equipment;

(b) No exhibit shall be permitted to obstruct or otherwise interfere with any part of the exhibition area, or passage to washrooms, checkrooms, exits or concession locations, or obscure, cover or screen, either in whole or in part, any other exhibit or exhibits, or any washrooms, checkrooms, exits or concession locations;

# Rules and Regulations

(c) The Exhibitor shall provide either a suitable background or booth for its exhibit, with all framework and exposed surfaces thereof properly covered and decorated, and with all background placements located solely along the solid lines shown on the Floor Plan, and not elsewhere. All booths must be carpeted at the Exhibitors' expense;

(d) No background, sign, decoration or other material or installation shall exceed (28) feet in height at any point or place, except in exhibit spaces, numbered, 1900 through 2400 where the height may not exceed fourteen (14) feet; and no side or dividing partition or other separator between exhibits shall extend higher than forty-eight (48) inches above floor level; five feet from aisle; (see diagram); and any sign or display that extends higher than the (8) foot background curtain may not have copy or design facing in the direction of other companies. The rear of the sign/display must be suitably finished or draped. Double-sided or rotating signs are only allowed for those Exhibitors who have an island or peninsula configuration within the confines of their booth. If a close-out is deemed necessary by the Committee, it becomes the responsibility of the Exhibitor to order it from the Contractor;

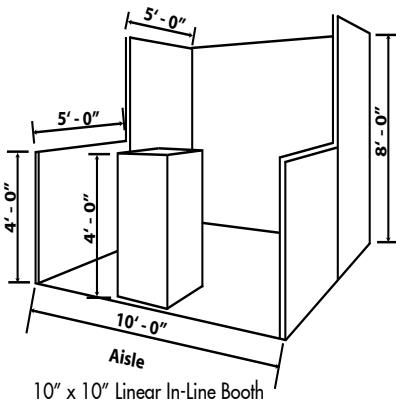

(e) Attachment to Exhibit Hall ceiling beams or truss is permitted only through the Official Full Service Contractor, Freeman. Requests for written approval of hanging signs truss and banners must be submitted to the Exhibits Committee by July 7, 2018, and to Freeman 60 days before installation. The request must include a description or drawing of the sign, truss or banner, proposed method of installation, location of hanging points, and total weight. All hanging signs, truss and banners must be set back at least 25% of the booth's width dimension from the back line of the booth. Hanging signs and graphics will not be permitted to a total length which exceeds 50% of the corresponding dimension of your booth. Please note that no signs, truss or banners may be hung without prior written approval from show management. Should there be any discrepancy between what the Committee approved and what is actually hung on-site, the

sign will be removed at the Exhibitor's expense; Hanging signs cannot exceed 28' for maximum height or be lower than 16' of said sign.

## Island/Peninsula Configuration

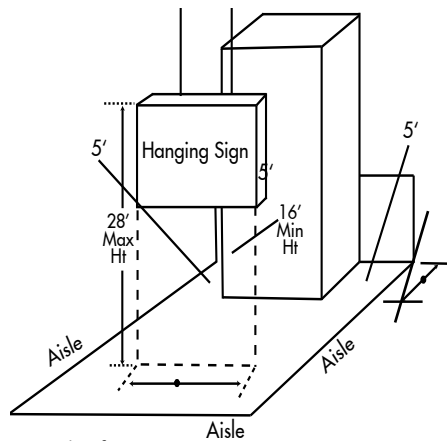

Length of sign not to exceed 50% of the corresponding dimension of the booth.

Set back at least 25% of the booths width dimension from the back line of the booth.

(f) Any awning, topping, covering or other projection or installation over the exhibit or extending forward from the face of the back or background of the exhibit shall not exceed sixty (60) inches in length or depth so long as such extension is 5 feet from the aisle and shall not, to any extent, obstruct, block or interfere with light or lighting for, or full use or visibility of, the space of any other Exhibitor;

(g) No Duplex exhibit shall be permitted without the written consent of the Committee with a 60 day notification, and no Exhibit, nor any part thereof, shall extend or project beyond the space assigned to the Exhibitor, and all of the Exhibitor's activities shall be conducted and carried on, and its representatives shall function and operate, solely within the confines of said space;

(h) No Exhibitor shall install, maintain, operate or use any public address or other sound system whatever or any loudspeaker of any kind without written permission of the Committee. Sound must be limited to the confines of the booth at a volume not to disturb or disrupt the activities of neighboring Exhibitors. Speakers and other sound devices should be positioned so as to direct sound into the booth rather than into the aisle. The Committee retains the right to determine acceptable levels of sound.

(i) No Exhibitor shall install, maintain, operate or use any light, lighting or other contrivance, device or equipment of any type, which in the judgement of the Committee, may be a source of interference or inconvenience to any other Exhibitor or to the Exhibition. Blinking lights

and rotating signage are only permitted with the prior written approval of the Committee.

(j) The Exhibitor shall, throughout the exhibition, keep and maintain its exhibit and all parts thereof in clean, dust free and otherwise orderly condition, with all literature, so called "hand-outs" and similar written or printed materials kept in neat and trim fashion, and any needful reserve quantities thereof properly stored in closed containers within the exhibit space. In the event that the Exhibitor shall cause or create any excessive litter or waste, the same will be removed by the Center's Building Service Department at the expense of the Exhibitor;

(k) The Exhibitor shall not: (1) make any material change in its exhibit or the displays therein after the initial installation thereof; (2) fail to keep its exhibit open, operating and adequately manned during the stated exhibition hours; or (3) discontinue, close or remove its exhibit, either in whole or in part, until the conclusion of the entire exhibition, unless otherwise directed or authorized by the Committee;

(l) The Committee shall be the sole judge as to acceptability of exhibits. An exhibit may not display any product or distribute advertisements for any product that infringes on the registered trademark, copyright or patent of another company. All exhibits shall conform to and comply with: all requirements of both the Committee and the Center;

(m) Gasoline powered vehicles used for exhibit or display will be allowed to operate in the Center only during move-in and move-out periods, and when on display shall be subject to the following restrictions: (1) no more than one gallon of fuel shall be kept in the tank of any vehicle; (2) no tank shall be re-fueled or emptied within the confines of the Center; (3) every tank shall be equipped with a key-lock gasoline cap; (4) all battery cables must be disconnected and the ends taped; (5) each vehicle must be locked during non-exhibit hours; (6) a tagged set of keys to each vehicle must be delivered to the Center's Security Office immediately upon entry of the vehicle into the Center; (7) no repairs or alterations to any vehicle shall be made in or at the Center; (8) adequate and suitable fire extinguishers and fire prevention equipment shall be provided by the Exhibitor and kept in close proximity to each vehicle; and (9) a protective sheet of visqueen, tarpaulin or comparable material shall be placed and kept under all vehicles and other movable equipment and devices in all areas within the Center in which such vehicles, equipment or devices are operating or being operated.



# Rules and Regulations

## 13. COMPLIANCE WITH LAW AND OTHER REQUIREMENTS

Exhibitor will obtain, at its expense, any permits required for the exhibit and shall provide the Center and the Committee with copies of said permits prior to August 29, 2018.

Exhibitor shall not use or permit the exhibit space to be used:

- (a) in conflict with any law, ordinances, rule or regulation of any governmental authority;
- (b) in any manner which could violate the Exhibitor's insurance or increase the rate of the Committee's or the Center's insurance;
- (c) in any manner which constitutes waste or nuisance;
- (d) in any manner which causes injury to the Center, alteration to the Center; or
- (e) in violation of the Center's Rules and Regulations, including without limitation the Javits Center Work Rules, as such may exist from time to time.

Exhibitors who want to sponsor any type of contest, raffle or drawing for prizes must obtain written permission from the Exhibits Committee. The following rules must be adhered to:

- (a) the Exhibitor must comply with all local, state and federal laws that apply to such raffles, contests or drawings;
- (b) contests, raffle or drawing rules must be posted at the booth. The rules must include: eligibility; date and time of drawing (contest, raffle); the words "no purchase necessary to enter"; odds of winning; how winners will be notified; how participants can find out who won; etc;
- (c) the Exhibitor must complete a form which will be supplied and agree to indemnify the Greater New York Dental Meeting in the event of any claims arising from the operation of the raffle or contest;
- (d) The Greater New York Dental Meeting must be notified of the name(s) of the winner(s) when the prize(s) have been awarded.

No Exhibitor shall construct, install, maintain or use as part of or in connection with its exhibit or the displays therein any material, equipment or other item or thing which does not comply with the Life Safety Code, with all requirements of the Fire Department of The City of New York, the Department of Buildings of The City of New York, the Bureau of Gas and Electricity of the Department of General Ser-

vices of The City of New York, the Division of Water Resources of the Department of Environmental Protection of The City of New York and the New York Board of Fire Underwriters, and with all other laws and requirements of the Federal, State, County and City departments, agencies, officials and authorities having jurisdiction in the premises.

Without limiting the foregoing provisions of this Paragraph "13", compliance is also required with the following:

- (a) Only such open flames as are essential to an exhibit and for which a Fire Department permit has been issued shall be allowed in or at the Center, and then only at such times, under such conditions and with such precautions as the Committee and the Center shall specify;
- (b) No explosives, fuel, combustible or hazardous material, decorative material not fireproofed or any materials or substances deemed hazardous by the Fire Department of The City of New York may be brought into the Center;
- (c) All curtains, draperies, carpets, fabrics, plastics and decorative and other items and materials to be included in or made part of any exhibit shall, at the Exhibitor's expense and prior to the delivery, installation or use thereof in or at the Center or the exhibit, be fireproofed or flameproofed by methods or means approved by the Fire Department of The City of New York, and the Exhibitor shall furnish, in advance, a notarized statement or certificate attesting to such fireproofing or flameproofing;
- (d) No oilcloth, tarpaper, plastics, synthetics or other materials of any kind which cannot or may not be effectively fireproofed or flameproofed shall be delivered, installed or used in or at any exhibit; and
- (e) The Exhibitor shall, at its expense, permit and arrange for any such flame test or tests as the Committee, the Center or the Fire Department of The City of New York may request or require.
- (f) any company demonstrating laser equipment on the exhibit floor must have a certified compliance officer in attendance.

## 14. ASSIGNMENT SUBLETTING OR SHARING

The Exhibitor shall use its space solely and exclusively for the exhibition of the materials, equipment or services normally manufactured, distributed or furnished by it in the regular course of its business, and for no other items or purposes of any kind.

The Exhibitor shall not assign, sublet, license or otherwise release, transfer, apportion or dis-

pose of its exhibit space or any part thereof, and any use of all or any part of said space by or for any person, firm or entity other than the Exhibitor, upon any terms whatever, is expressly prohibited.

Each space may be used only by a single business entity and no sharing of space will be permitted.

## 15. EXHIBITS OR EDUCATIONAL PROGRAMS IN OTHER AREAS

**The Exhibitor shall, during the Meeting period from Friday, November 23, 2018, through Wednesday, November 28, 2018, use or employ for exhibit or display purposes, or for the conduct of seminars, clinics, promotions, or for the distribution of samples, literature or like items, or for any similar or related activities involved in or connected with its business or business affairs or operations, only the exhibit space for which it has contracted with the Committee, and shall not, during that period, use or attempt to use, for any such purposes, whether directly or indirectly, any other area in the Center, or any exhibit, display or other space of any type in any hotel, hall, room or other quarters or facilities of any kind located within The City of New York without the written approval of the Committee. Any failure or refusal of the Exhibitor to comply with or conform to the provisions of this Paragraph "15" shall constitute a substantial violation of these Rules and Regulations.**

Evening social functions that incorporate any educational component including lecture, seminar, clinic and/or product demonstration, shall be permitted in appropriate forums.

## 16. NEW PRODUCT AND TECHNOLOGY PAVILION

Exhibitors can display their newest products and/or services free of charge at the New Product and Technology, centrally located for prime visibility.

## 17. CARE OF THE CENTER

The Exhibitor shall be responsible for all damage to the Center, its structures, furnishings, facilities, equipment and appurtenances, caused or contributed to by the Exhibitor, its agents, employees, representatives, guests or visitors, irrespective of whether such damage shall be attributable to any negligence on the part of the Exhibitor; and the Exhibitor shall promptly pay for such damage and for all costs and expenses on account thereof, and shall indemnify, keep and hold harmless and defend the Committee from and against the same. In addition:

- (a) The Exhibitor shall not: (1) mark or paint on, drill, screw or cut into, place hooks or tacks, or

# Rules and Regulations

in any manner injure, mar, deface or alter or otherwise change any walls, columns, partitions, floors, escalators, doors, signs or other aspects or parts of the Center, its structures, furnishings, facilities, equipment or appurtenances; (2) tape, hang, paste, tack, nail, wire, screw or otherwise affix, attach, append or otherwise connect any signs, bills, self adhesive stickers, badges, banners, decorations, displays, advertisements or other articles, materials, items or things to walls, columns, partitions, floors, escalators, doors, signs or other aspects or parts of the Center, its said structures, furnishings, facilities, equipment or appurtenances; or (3) remove any ceiling or floor tiles or wall plates; (4) lay any carpet over Center carpets; or (5) remove, disable, disconnect, detach, impair or otherwise interfere with any of the Center's automatic door closing devices or equipment, or prop open or otherwise keep open any of the Center's doors or other accesses;

(b) At no time shall the Exhibitor bring into, store or keep in or at the Center any gasoline, kerosene, acetylene, helium or other fuel or volatile or inflammable liquids or gases, or any fireworks, flash pots (whether empty or filled), explosives, combustibles or other hazardous substances, materials, fluids or gases except as otherwise provided in Paragraph "12" hereof, and except such as shall be permitted by law and the authorities having jurisdiction thereof, and then only at such times, under such conditions and with such precautions as the Committee and the Center shall specify;

(c) The Exhibitor shall not pour grease, contaminated material or any other waste materials into the Center's drains, and shall use for such purpose only the metal containers that will be made available, at the Exhibitor's request, by the Center's Building Service Department;

(d) The Exhibitor shall not use in either its exhibit space or in any other area of the Center: any so-called "glitter" or like materials; or any so-called "stick-ons" or other adhesive decals, badges, velcro or similar items of any kind;

(e) The Exhibitor shall exercise the utmost care and caution in the use of lamps, lights and other electrical equipment and devices included in its exhibit, and, at all such times as its exhibit may be unmanned or unattended, all electricity and electrical current for said equipment and devices shall be effectively shut off and secured; and

(f) The Exhibitor shall not bring into the Center or keep or use in its exhibit any electrical or related or other equipment or devices which have not been officially approved by the Underwriters Laboratories.

## 18. ELECTRICAL AND OTHER CONNECTIONS

No wiring, installations or connections for any utility or other services or facilities, including, but not limited to, electrical, video, audio, water, compressed air and other equipment and accommodations, shall be made or effected by or for the Exhibitor without the prior written consent of the Committee and the Center and, if such consent is granted, then such wiring, installations and connections shall be made at the sole cost and expense of the Exhibitor, in such manner and by such means as the Center may require, by such contractors as shall be designated by the Center, and under the supervision of the Center's Building Service Department. The Exhibitor shall pay directly to the Center, promptly upon receipt of bills or invoices therefor, all charges for such wiring, installations and connections and for the operation and use of the same, as well as for the costs and expenses to be incurred for the removal thereof. The Center may require of the Exhibitor advance deposits or payments for all such charges.

At least four (4) months prior to the commencement of the Meeting, the Exhibitor shall advise the Committee in writing of the wiring, installations and connections it seeks for use at said Meeting and, in the absence of receipt of such advice, either the Committee or the Center may thereafter refuse or deem itself unable to grant or consider granting consent for the same.

There will be available through existing facilities at the Center alternating (AC) electric current of 110 volt, 60 amp, single phase, or 208 volt, 60 amp, single or three phase, or 460 volt. If the Exhibitor anticipates a need for other or different electric current for its exhibit, written notice thereof, within the above mentioned period of four (4) months, shall be given by the Exhibitor to both the Committee and the Center, but no assurance is given that such other or different electric current can or will be provided or that consent thereto will be granted by the Center or the Committee.

Exhibitors may plug in their own electrical devices and equipment for properly ordered 110 volt electrical service of 1500 watts or less. All plugs must be U-ground 3-prong plugs.

## 19. ELECTRICAL SIGNS AND DEVICES

No flickering, strobe, flashing, blinking, changing, rotating, laser lights or similar sign, sign-board or equipment may be installed or used by the Exhibitor without written permission of the Committee under any circumstances whatever, and no other electrical sign, device or equipment of any type shall be installed or used by the Exhibitor without the prior written consent of the Committee and the Center.

All decorative fountains must be waterproof and must be pre-tested and approved by the Center's Building and Service Department prior to installation.

Any electrical connections, light, truss, etc., must remain within the designated space, unless written permission is given by the GNYDM Committee.

In the event that, due to fire or other casualty, strikes, lockouts or labor difficulties, construction operations, severe weather conditions, explosions, sabotage, accident, riot, civil commotion, terrorism, act of war or any action or condition of the Center, or any litigation, action of the elements, act of God, governmental restrictions, legal requirements or other circumstances beyond the Committee's control, the Meeting is not held, the exhibition is barred, prevented or cancelled, or the Exhibitor's space is wholly unavailable for its use (for reasons other than any breach or default on the part of the Exhibitor) then and in any of such events the sole obligation of the Committee shall be to refund to the Exhibitor prorated daily sums theretofore paid to the Committee under the Exhibitor's contract, and both parties shall thereupon be deemed released of and from all further liability under said contract.

## 20. CIRCUMSTANCES BEYOND CONTROL

In the event that, due to any of the aforesaid events, occurrences, contingencies or circumstances, the exhibition shall terminate or be discontinued, or the Exhibitor shall be deprived of its space (for reasons other than its own breach or default), after the commencement of the exhibition but prior to the scheduled conclusion thereof as hereinbefore specified, then the contract charge for the Exhibitor's said space shall be apportioned appropriately, the Committee shall refund to the Exhibitor the pro rata portion of said contract charge applicable to the unused period of the exhibition, and both parties shall thereupon be deemed released of and from all further liability under said contract.

## 21. SECURITY

Although the Committee intends to adopt certain security measures for the Meeting, the same shall not be deemed nor constitute, in any respect or to any extent, the assumption by the Committee or the Center of any liability or responsibility for the safety or security of the Exhibitor, its agents, employees, representatives, guests or visitors or its exhibit, displays or other property. There shall be no bailor and bailee relationship between the Committee or the Center and the Exhibitors, or any person described above. Exhibitor will promptly notify the Committee and the Center, in writing of any incident or loss or damage to the property of Exhibitor or invitees occurring within the premises during the Meeting.

# Rules and Regulations

The Exhibitor is therefor urged to take all such steps, measures and precautions as may be necessary to protect itself, its agents, employees, representatives, guests and visitors, as well as its exhibit, displays and other property, against all possible injury, damage, loss and destruction during the Meeting, including without limitation, loss or damage occasioned by theft, fire, act of God or other insurable casualty, and if the Exhibitor shall seek or require any special safeguards or any extra security, it shall make arrangements therefor, in advance of the commencement of the Meeting, with the Security Contractor for the Meeting.

## 22. LIABILITY

Exhibitor is fully responsible for all acts or omissions of its contractors and vendors. Exhibitor will ensure that such persons comply with Javits Center Work Rules set forth in Paragraph "9" hereof and will be responsible for any substantial non-compliance by such persons.

There shall be no liability or responsibility on the part of the Committee, the Center, the Security Contractor for the Meeting, or the Official Full Service Contractor for the Meeting, or any of their respective agents, employees and representatives, for any injury or damage to the Exhibitor, its agents, employees, representatives, guests or visitors, or for any loss, damage or destruction of any property belonging to the Exhibitor or used in or in connection with its exhibit or the displays therein. This shall apply irrespective of the manner in which or the circumstances under which any such injury, damage, loss or destruction may occur, and irrespective of whether the same may arise out of any negligence or claimed negligence on the part of the Committee, the Center, the Security Contractor or the Full Service Contractor. All claims and causes of action therefor shall be, and be deemed to be waived, released and discharged for all purposes.

The Exhibitor shall indemnify, keep and hold safe and harmless and defend the Committee, the Center, the State of New York, the New York Convention Center Development Corporation, the Empire State Development Corporation, the Triborough Bridge and Tunnel Authority, the Security Contractor, and the Official Full Service Contractor and their respective boards of directors, officers, agents, and employees and each of them ("Indemnities") from all claims, losses, liability, damages, actions and judgments arising in, at, out of or in connection with the Exhibitor's exhibit or the installation, maintenance, conduct, use, operation or removal of said exhibit or any part or parts thereof. This includes without limitation, any and all such claims, losses, damages and judgments which may arise out of, be attributable to or in any manner or to any extent involve any negligence or claimed negligence

on the part of the Committee, the Center, the Security Contractor or the Official Full Service Contractor.

On or before August 29, 2018, the Exhibitor agrees to provide the Committee with an original certificate of insurance issued by an insurance carrier authorized to do business in The State of New York, evidencing the following insurance coverage in support of the Exhibitor's aforesaid agreement to indemnify, keep and hold safe and harmless and defend. In addition to the Exhibitor, such certificate of insurance shall name as additional insureds the Indemnities.

(a) General Liability-\$1,000,000 per occurrence/ \$2,000,000 aggregate

(b) Workmen's Compensation covering employers liability as well as Workers Compensation for the employees:

Bodily injury by accident:

\$100,000 each accident

Bodily injury by disease:

\$500,000 policy limit

Bodily injury by disease:

\$100,000 each employee.

(c) Automobile-\$500,000 per occurrence combined single limit.

(d) Excess Liability-\$3,000,000.

All insurance coverage shall also contain a "waiver of subrogation" endorsement and shall provide that the Greater New York Dental Meeting be given at least 30 days notice prior to any termination, cancellation or material change in insurance coverage.

Please note: Facsimiles or photocopies of the Certificate of Insurance are not accepted. Only original Certificates will satisfy this request.

Failure to comply with this regulation may jeopardize your ability to exhibit at the Greater New York Dental Meeting.

## 23. SHIPMENTS AND CONSIGNMENTS

All exhibit materials and equipment shipped by or on behalf of the Exhibitor for delivery at the Center prior to 8:00 A.M., Friday, November 23, 2018, must be consigned to the Official Full Service Contractor for the Meeting, to wit, Freeman, 909 Newark Turnpike, Kearny, New Jersey 07032 and, if further information should be sought as to any such consignment, the Exhibitor may telephone the Official Full Service Contractor at (201) 998-6444. No shipment of any materials or equipment will be accepted at the Center in advance of Friday, November 23, 2018.

Any shipments made by or on behalf of the Exhibitor for delivery at the Center on or after November 23, 2018, shall be consigned to the

Exhibitor in care of the Meeting at the Center.

All shipments by or for the Exhibitor, irrespective of when made, must be on a prepaid basis and clearly marked with the Exhibitor's space number at the exhibition. All deliveries of such shipments will terminate at the Center's loading dock area, and all pick ups of such shipments are to be made at said loading dock area. The handling of such shipments and the transfer of the same to and from the Exhibitor's space at the exhibition will be performed, at the Exhibitor's expense, by Javits Center labor employed or engaged by the Official Full Service Contractor for such purposes. All deliveries intended to be made by the Exhibitor directly to the Center must first be checked in at the Center's Traffic Control location at West 39th Street and 12th Avenue, New York, New York, (Big Blue Trailer) and all papers for those deliveries must immediately be turned over to the Office of the Traffic Control Supervisor in said Big Blue Trailer. Such deliveries will be received ONLY on Friday and Saturday, November 23 and 24, 2018, both of which dates are overtime days for the Official Full Service Contractor and overtime rates will therefor apply. To avoid such overtime expense, the Exhibitor may, instead, ship in advance to Freeman, and all deliveries received at the Warehouse prior to Tuesday, November 13, 2018, will be forwarded to the Center by 8:00 A.M. on Friday, November 23, 2018. All deliveries received at the Warehouse from Friday, October 19, 2018, through Tuesday, November 13, 2018, will be forwarded to the Center on Friday, November 23, 2018, beginning at 8:00 A.M., and overtime rates will be applicable to all such deliveries. There will be no extra charge for the storage of exhibit materials or equipment at the Warehouse since such charge is included in the advance receiving rate. FedEx and UPS do not deliver to the Javits Center on Friday and Saturday, November 23-24, 2018.

During the setting-up and dismantling of exhibits, or the moving in or out of the same as specified in Paragraphs "6" through "11" hereof, as well as during the exhibition itself, no sidewalk deliveries or pick ups will be permitted under any conditions whatever, and no exhibit materials or equipment of any kind, other than such as can properly be hand-carried, shall be taken, moved or transported on any escalators or passenger elevators in the Center.

All hand-carried materials or equipment shall be of such size and quantity as may readily be carried through revolving doors without impairment or interruption of normal operation and use of such doors.

Any use of hand trucks, dollies or flats is prohibited, but Exhibitors may use hand luggage with integral wheels, sample cases or folding baggage carts which comply with the require-

# Rules and Regulations

ments stated above for hand-carried materials or equipment.

There shall be no liability or responsibility whatever on the part of the Committee, the Center, the Security Contractor or the Official Full Service Contractor for any loss, damage or destruction of any of the materials, equipment or other property shipped by or for the Exhibitor, irrespective of whether the same be consigned to or picked up by or for the Committee, the Center, the Exhibitor, the Security Contractor or the Official Full Service Contractor, or any other person or party.

In the event of any labor or related dispute, whether jurisdictional or otherwise, or in the event of any other problem or difficulty involved in or connected with any shipment, consignment or pick up by or for the Exhibitor, then the Committee or the Center may reject, accept, move, delay, immobilize or otherwise deal with any such shipment, consignment or pick up of any or all of the Exhibitor's materials, equipment and other property included therein, in any such manner and by any such means as the Committee or the Center may deem necessary in the circumstances, and without any liability therefor to the Exhibitor.

## 24. RESTRICTIONS AND REQUIREMENTS

The Committee shall have and expressly reserves, the right to conduct, carry on, maintain, regulate and operate the exhibition in such manner and by such means as it, in its sole discretion, deems advisable or proper.

The Committee shall have the further right to prohibit, bar, prevent and remove any exhibit or proposed exhibit, or any part or portion thereof, which in the judgment of the Committee is unsuitable or inappropriate for the exhibition or is not in keeping with the character, standards or purposes of the exhibition. Such right shall extend, but shall not be limited, to all materials, equipment, displays, installations and other items or things included in, constituting part of, or used or referred to in or in connection with any such exhibit.

The Committee shall also have full right and authority to relocate Exhibitors and to alter or revise the floor plan for any cause or reason that the Committee, in its judgment, may deem necessary or advisable.

The Committee shall have the right to bar, eject and remove from the exhibition and the area in which the same is conducted any and all persons whom it may deem disorderly or objectionable or who fail or refuse to comply with any of these Rules and Regulations.

Smoking or carrying a lighted cigar, cigarette or pipe in any exhibition area or in any other room or area used by or reserved for the Meet-

ing is strictly forbidden. The distribution of balloons, push or pulled wheeled baggage and any and all other similar promotional items are prohibited.

The movement of palletized freight using a pallet jack is prohibited on all carpets, unless the Committee and the Center grant their permission, in which case the carpet must be protected with plywood or masonite.

No alcoholic beverages of any nature shall be brought into the Center and no animals or pets shall be allowed in the Center except such as constitute part of an approved exhibit or are seeing-eye dogs.

No wheelchairs, carriages or similar or related equipment or devices are permitted on escalators.

The Center has the right to operate all concessions at the Center, and Exhibitor shall not sell or dispense any concessions or samples in the Center without the prior written approval of the Committee and the Center, except Exhibitor may, however, take orders for services or merchandise which are the subject of the Meeting and distribute samples incident to a particular exhibit at the Meeting, **and then only within the confines of its exhibit**, and provided that no charge is made for the same. Distribution must be done in a dignified manner, must not create a nuisance nor interfere with adjoining exhibits. Should a nuisance or traffic problem due to the distribution of product, samples or souvenirs occur, the Exhibitor will be required to halt distribution, or to distribute the item only at certain times. However, and apart from such samples or souvenirs, no delivery or transfer of goods or other items shall, under any circumstances, be made in any exhibition area, and no payment for any such goods or other items, whether in cash, by check or credit card, or in any other form, shall be made, processed or accepted in said area.

Except in designated locations such as Pavilions, all aisles must at all times remain open and unobstructed, and any use of any aisle for an exhibit, display, demonstration, solicitation of business, distribution of materials, or any other purpose, except free passage through the exhibition area, is expressly prohibited. Any violation of this rule by an Exhibitor will be deemed a substantial breach of its contract with the Committee and its obligations to the Center.

Any exhibit, display, demonstration, solicitation of business, distribution of materials or other advertising, publicity, canvassing or similar or related activities at the exhibition by, for or on behalf of any person, firm or entity other than the Exhibitor is forbidden.

Exhibitor personnel may not enter, photograph or videotape the exhibit space of another Exhibitor without permission of the latter.

Promotional literature and booth copy may cite in footnotes references from dental and other scientific literature, provided the reference is truthful and is a fair and accurate representation of the body of literature supporting the claim. Unwarranted disparagement or unfair comparisons of a competitor's products or services is not allowed.

Firms and representatives not assigned exhibit space are prohibited from soliciting business in any form in the exhibition hall in the Javits Convention Center. Violators of this prohibition will be required to leave the building. Grey market product sales without manufacturer's approval is prohibited.

Copyrighted music can only be used on the Exhibit Floor with written permission from the Committee after submission of proof of licensing agreement between the Exhibitor and licensing agencies. Exhibitors should be aware that music played in their booths, whether live or recorded, may be subject to laws governing the use of copyrighted compositions. Exhibitor is solely responsible for any fines or charges incurred by the Meeting for the use of the Exhibitor's music.

**"Live" demonstrations or treatment on patients are not permitted in the Exhibit Hall under any circumstances.**

The Greater New York Dental Meeting has adopted the following policy for Laser Company Exhibitors in the exhibition area:

- (a) Lasers must be operated by trained authorized personnel acting under a senior compliance officer who must be present on-site;
- (b) Adequate warning signage of laser usage with the appropriate wavelength being used must be posted;
- (c) Safety glasses of the proper density and wavelength must be worn by all attendees in the demonstration area;
- (d) Water availability and adequate and suitable fire extinguishers must be in near proximity of the laser;
- (e) Demonstrative enclosures with proper density and wavelength observation areas must be utilized;
- (f) Combustible and explosive material must be removed from the laser demonstration area prior to usage;
- (g) All coverings in the Javits Center must be fire retardant, which includes coverings utilized in the area near the laser;
- (h) Beam and reflection protection modalities must be utilized;
- (i) Proper electrical and lighting installation must be maintained;

# Rules and Regulations

(j) No laser equipment may be left unattended in operable condition at any time and a staff member must always be present at the booth during the show hours;

(k) **IMPORTANT NOTE:** A description of each piece of laser equipment and their safety features must be submitted to the Greater New York Dental Meeting by August 24, 2018, and failure to submit such description may result in denial of the laser to be shown/demonstrated or denial of exhibit space.

## 25. REGISTRATION

Each person attending the exhibition is required to promptly register with the Committee and shall, at all times during the exhibition wear the badge issued upon such registration. Any transfer of any such badge is prohibited and, in the event that any such transfer is made, both the individual to whom the badge was issued and the one to whom it was transferred will be compelled to immediately leave the Meeting areas and will be barred from further attendance thereat. Badges are the property of the Committee and are not transferable.

The Exhibitor's representatives at the exhibition shall be limited and restricted to its executives and employees, and then only in such numbers as the Committee, in its judgment, shall deem necessary. Consultants are not considered employees of an Exhibitor. Each of said representatives shall register with the Committee and shall, at all times during the exhibition, wear in conspicuous fashion the badge to be issued upon such registration. The Exhibitor shall not allow or permit any person or persons into its exhibit space, except its said registered representatives.

Exhibiting firms will be permitted to register up to twelve (12) representatives per booth space

purchased. Exhibiting companies are allowed to rotate booth staff during the Meeting by returning an Exhibitor badge to Exhibitor registration and requesting a replacement for newly arrived staff who must show proof of employment by the exhibiting firm.

It is expressly understood that, under no circumstances, shall the Exhibitor register a dentist unless he or she is in its full time employ. Any failure or refusal of the Exhibitor to comply with or conform to the provisions of this Paragraph "25" shall constitute a substantial violation of these Rules and Regulations.

## 26. INTEGRAL PART OF CONTRACT

Each and all of the provisions of these Rules and Regulations shall be deemed to be and constitute an integral part of the Exhibitor's contract for its space at the Meeting, with the same full force and effect as if set forth at length in said contract. The Committee reserves the right to interpret these Rules and Regulations in its sole discretion as well as the right to decide all matters relevant to the Meeting which may not be specifically covered by these Rules and Regulations.

## 27. DEFAULT

In the event that the Exhibitor shall, at any time after payment to the Committee of the full contract charge for its space at the Meeting, fail to comply with or otherwise violate any of the terms of said contract (including any of the provisions of these Rules and Regulations) on its part to be complied with, then and in that event and in addition to any and all other rights and remedies thereby available to it, the Committee may, at its option, terminate said contract, retain as liquidated damages all sums paid by the Exhibitor thereunder, remove any and all property of said Exhibitor which

may be in the exhibition area, and assign the Exhibitor's space to any third party or third parties or use the same for such other purposes as it may deem necessary, all without notice and without further liability to the Exhibitor.

In the event that the Committee shall default (other than by reason of any of the events, occurrences, contingencies or circumstances specified in Paragraph "20" hereof) in complying with the terms of said contract on its part to be complied with, then and in that event its liability to the Exhibitor for any and all damages which the Exhibitor may thereby suffer, sustain or incur shall in no event exceed, and shall for all purposes be limited to, the amount theretofore paid by the Exhibitor to the Committee under the aforesaid contract.

## 28. GOVERNING LAWS

These Rules and Regulations and the contract with the Exhibitor of which the same form a part shall be governed by, and shall be interpreted and construed under and in accordance with, the laws of The State of New York applicable to agreements executed and to be performed entirely within that State. The Exhibitor hereby consents to the jurisdiction of the courts of The State of New York and the United States District Court for the Southern District of New York with respect to any matter arising with respect to these Rules and Regulations and the aforesaid contract, shall subject itself to the jurisdiction of such courts and agrees that service of process upon it may be made in any manner permitted by the laws of The State of New York. Without limiting the generality of the foregoing, service of process will be deemed sufficient if sent by registered or certified mail to the Exhibitor at the address set forth in the Exhibitor's' contract.



The Greater New York Dental Meeting takes pictures throughout its event. By exhibiting/attending the Meeting, you consent to the GNYDM's use of the picture in its publications. The GNYDM will not be liable for any claims associated with its use. Moreover, you agree that you are not entitled to any remuneration for said use.



# GREATER NEW YORK DENTAL MEETING

## APPLICATION/CONTRACT FOR EXHIBIT SPACE

This form must be returned no later than:  
March 13, 2018 for Seniority Assignments

### GREATER NEW YORK DENTAL MEETING™

200 West 41st Street - Suite 800  
New York, New York 10036-7203  
Phone: (212) 398-6922 Fax: (212) 398-6934  
E-mail: carla@gnydm.com  
Website: [www.gnydm.com](http://www.gnydm.com)

### 94<sup>th</sup> Annual Session

November 23 – November 28, 2018

### Exhibit Dates:

November 25 - November 28, 2018

Jacob K. Javits Convention Center  
New York City, New York

Instructions: Type or clearly print. Sign and return the original copy to the above address, with **\$1000.00 deposit per booth, made payable to the Greater New York Dental Meeting. Final payment is due on August 1. Full payment must accompany contract after August 1.** Valid Certificate of Insurance is required. Full payment is required for international companies. The company name, address, city, state/country, customer service phone, fax numbers, E-mail and Website address as shown on this form are for use in the Program and Exhibit Guide.

Company Name \_\_\_\_\_

Address \_\_\_\_\_ City, State/Country, Zip Code \_\_\_\_\_

Company Email \_\_\_\_\_ Company Website \_\_\_\_\_

Customer Service Telephone ( ) \_\_\_\_\_ Fax \_\_\_\_\_

Exhibit Contact Person \_\_\_\_\_ Email \_\_\_\_\_ Telephone \_\_\_\_\_ Fax \_\_\_\_\_

Advertising Contact Person \_\_\_\_\_ Email \_\_\_\_\_ Telephone \_\_\_\_\_ Fax \_\_\_\_\_

Sponsorship Contact Person \_\_\_\_\_ Email \_\_\_\_\_ Telephone \_\_\_\_\_ Fax \_\_\_\_\_

Size of Booth Space required \_\_\_\_\_ ft. deep x \_\_\_\_\_ ft. wide Total number of Booths requested \_\_\_\_\_

Indicate preference  Standard  Corner  Island  Peninsula  Pavilion

Number of Booths \_\_\_\_\_ x \$1,000.00 = Total deposit enclosed \$ \_\_\_\_\_

Number of Conference Rooms \_\_\_\_\_ x \$1,000.00 = Total deposit enclosed \$ \_\_\_\_\_

Number of Executive Suites (only 4 available) \_\_\_\_\_ x \$1,400.00 = Total deposit enclosed \$ \_\_\_\_\_

Daily Conference Room \_\_\_\_\_ 10 x 10 = \$950.00/ Daily Conference Room \_\_\_\_\_ 10 x 20 = \$1,480.00 \$ \_\_\_\_\_

### APPLICATIONS RECEIVED WITHOUT DEPOSIT OR FULL PAYMENT PER BOOTH WILL NOT BE PROCESSED.

If possible, we do not wish to be next to or across from: \_\_\_\_\_

Provide a brief description of primary products and/or services: \_\_\_\_\_

PRODUCT CLASSIFICATION: From the classification listing on the reverse side of this application/contract, select the appropriate code numbers for the categories which best describe your products/services. Indicate code for each product description in the space below up to your maximum (See reverse side). Every effort will be made to include company name, company information and product listings in the Program and Exhibit Guide for all Application/Contracts received prior to **June 15, 2018.**

- |           |           |           |           |           |
|-----------|-----------|-----------|-----------|-----------|
| 1. _____  | 2. _____  | 3. _____  | 4. _____  | 5. _____  |
| 6. _____  | 7. _____  | 8. _____  | 9. _____  | 10. _____ |
| 11. _____ | 12. _____ | 13. _____ | 14. _____ | 15. _____ |

**THE GREATER NEW YORK DENTAL MEETING DOES NOT ASSUME ANY LIABILITY OR RESPONSIBILITY FOR ANY TYPOGRAPHICAL ERRORS, OMISSIONS OR INACCURACIES OF ANY KIND IN ANY OF ITS PUBLICATIONS.**

**WE AGREE TO ABIDE BY ALL RULES AND REGULATIONS GOVERNING THE MEETING AS PUBLISHED IN THE 2018 EXHIBITORS' PROSPECTUS, WHICH ARE A PART OF THIS CONTRACT AS IF PUBLISHED HEREIN.**

AUTHORIZED SIGNATURE \_\_\_\_\_ TITLE \_\_\_\_\_ DATE \_\_\_\_\_

PRINT FULL NAME \_\_\_\_\_

# GREATER NEW YORK DENTAL MEETING

## PRODUCT CLASSIFICATION FORM

The table below indicates the maximum listings allowed to an exhibitor:

**1-2 booths...up to 6 product listings**

**3-4 booths...up to 8 product listings**

**5-6 booths...up to 10 product listings**

**7-10 booths...up to 12 product listings**

**10 or more booths...up to 15 product listings**

<b>AB05</b>	Abrasives, Disks/Points/Wheels	<b>CU05</b>	Curing Units	<b>IR05</b>	Irrigators	<b>PU02</b>	Publications, Professional & Scientific
<b>AC05</b>	Acrylics & Accessories	<b>DA05</b>	Darkroom Equipment & Supplies	<b>LA05</b>	Laboratory Equipment & Supplies	<b>PU05</b>	Pulp Testers
<b>AI04</b>	Air Abrasives	<b>DE05</b>	Dental Dealers	<b>LA07</b>	Lasers	<b>RE05</b>	Record Keeping Systems
<b>AI05</b>	Air Compressors	<b>DE06</b>	Dental Equipment, Mobile/Portable	<b>LA09</b>	Lathes, Chucks	<b>RE06</b>	Refining Resources
<b>AL05</b>	Alloys	<b>DE07</b>	Dental Hygiene Materials	<b>LA12</b>	Laundry Services	<b>RE08</b>	Repair Kits, Denture
<b>AM05</b>	Amalgamators	<b>DE08</b>	Dental Laboratories	<b>LE01</b>	Leasing	<b>RE09</b>	Repair Services
<b>AN05</b>	Analgesia/Anesthesia Equipment & Supplies	<b>DE09</b>	Dental Lab Equipment & Supplies	<b>LI05</b>	Lights, Operating	<b>RE10</b>	Restorative Materials & Accessories
<b>AN06</b>	Analgesics	<b>DE10</b>	Dental Office Design	<b>LI06</b>	Lights, Other	<b>RE11</b>	Retirement Programs
<b>AN08</b>	Anatomical Models	<b>DE12</b>	Dentifrices	<b>LO05</b>	Loupes	<b>RE13</b>	Retraction Materials
<b>AN10</b>	Anesthetics	<b>DE14</b>	Denture Adhesives	<b>LU05</b>	Lubricants	<b>RU05</b>	Rubber Dam & Accessories
<b>AN12</b>	Antibacterial Soaps & Detergents	<b>DE15</b>	Denture Base, Reline, Repair Resins	<b>MA05</b>	Marketing Aids & Research	<b>SA05</b>	Saliva Ejectors
<b>AN14</b>	Antibiotics	<b>DE16</b>	Denture Cleaners	<b>MA08</b>	Masks	<b>SA10</b>	Saliva, Synthetic
<b>AP05</b>	Apex Locators	<b>DI05</b>	Diagnosis & Testing Services	<b>ME05</b>	Medical Waste Services	<b>SC05</b>	Scalers
<b>AR05</b>	Articulating Paper, Film/Ribbon	<b>DI07</b>	Diagnostic Equipment, All Types & Services	<b>ME07</b>	Medicaments	<b>SC06</b>	Scalers, Ultrasonic
<b>AR06</b>	Articulators	<b>DI09</b>	Diamond Points & Disks	<b>ME09</b>	Metal, Recovery & Refining	<b>SH05</b>	Sharpeners, Instrument
<b>AS05</b>	Asepsis Products	<b>DI11</b>	Dietary Products	<b>MI05</b>	Microscopes	<b>SL05</b>	Sleep Apnea
<b>AT05</b>	Attachments	<b>DI12</b>	Digital Imaging	<b>MI08</b>	Mirrors (Hand)	<b>SN01</b>	Snoring Appliances
<b>AU05</b>	Audiovisual Equipment & Materials	<b>DI13</b>	Digital Impression Taking Systems	<b>MO05</b>	Model Forming Tools & Accessories	<b>SO05</b>	Soaps & Lotions
<b>AU08</b>	Autoclaves & Accessories	<b>DI14</b>	Digital Radiography	<b>MO06</b>	Models Demonstration	<b>SO08</b>	Solder, Fluxes
<b>BL02</b>	Bleaching Products	<b>DI15</b>	Disinfecting Solutions	<b>MO09</b>	Mouthwashes (Rinses)	<b>SK03</b>	Skin Care Products
<b>BL05</b>	Blood Pressure Diagnostic Instruments	<b>DI16</b>	Disks, Mandrels & Strips	<b>NU05</b>	Nutritional Products	<b>ST05</b>	Sterilizers
<b>BO05</b>	Bonding Agents	<b>DI18</b>	Disposable Needles	<b>OF05</b>	Office Equipment, Furniture/Decor	<b>ST06</b>	Sterilizer Accessories
<b>BO07</b>	Bone-Grafting Materials	<b>DI20</b>	Disposable Products	<b>OF06</b>	Office Supplies	<b>ST07</b>	Sterilizing & Disinfecting Solutions
<b>BO09</b>	Bookkeeping Systems	<b>DR05</b>	Dry Air Systems, Filtration	<b>OP05</b>	Operating Room Supplies & Equipment	<b>ST10</b>	Stools, Lab
<b>BO11</b>	Books	<b>ED05</b>	Education Materials	<b>OP06</b>	Optical Aids	<b>ST11</b>	Stools, Operatory
<b>BU05</b>	Burs, All Types	<b>EL05</b>	Electrosurgical Equipment	<b>OR05</b>	Oral Hygiene Aids	<b>SU05</b>	Surgical Supplies
<b>BU07</b>	Business & Finance Service	<b>EM05</b>	Emergency Drugs/Equipment	<b>OR06</b>	Oral Irrigation Devices	<b>SU08</b>	Sutures
<b>BU08</b>	Business Systems & Equipment	<b>EN05</b>	Endodontic Instruments & Supplies	<b>OR09</b>	Orthodontic Materials & Accessories	<b>SY05</b>	Syringes
<b>CA01</b>	Cabinets	<b>EQ05</b>	Equipment Leasing	<b>OS05</b>	OSHA Compliance Products/Services	<b>TE05</b>	Teeth, Artificial
<b>CA03</b>	CAD/CAM Materials & Accessories	<b>EQ06</b>	Equipment Repair & Maintenance	<b>OT01</b>	Other	<b>TE08</b>	Telecom, Services & Equipment
<b>CA04</b>	CAD/CAM Outsourcing	<b>EV05</b>	Evacuators & Evacuator Systems	<b>PA01</b>	Payroll Services	<b>TM05</b>	TMD Diagnostic & Treatment Products
<b>CA05</b>	CAD/CAM Systems	<b>EX05</b>	Exercise Equipment	<b>PA05</b>	Pads, Mixing	<b>TO05</b>	Tooth Shade Guides
<b>CA06</b>	Cameras, Extra Oral	<b>EY05</b>	Eyewear, Protective	<b>PA08</b>	Paper Products	<b>TO07</b>	Toothbrushes, Hand
<b>CA07</b>	Cameras, Intra Oral	<b>FI05</b>	Fiber Optic Products	<b>PA10</b>	Patient Financing Services	<b>TO09</b>	Toothbrushes, Power
<b>CA09</b>	Casting Machines & Accessories	<b>FI08</b>	Filling Materials & Accessories	<b>PA11</b>	Patient Record Forms	<b>TO12</b>	Torches
<b>CA10</b>	Casting Alloys	<b>FI10</b>	Financial Planning & Services	<b>PA21</b>	Patient Education Materials	<b>TO14</b>	Toys & Novelties
<b>CE05</b>	Cements, All Types	<b>FL05</b>	Flossing Materials	<b>PE03</b>	Periodicals, Professional/Scientific	<b>TR05</b>	Trays, Impression
<b>CH05</b>	Chairs & Accessories	<b>FL08</b>	Flouride Products	<b>PE05</b>	Periodontal Exam Systems	<b>UL05</b>	Ultrasonic Equipment & Supplies
<b>CH08</b>	Chewing Gum	<b>FU05</b>	Furnaces	<b>PE06</b>	Periodontal Materials	<b>UN05</b>	Uniforms, Gowns/Shoes
<b>CL05</b>	Claim Processing	<b>FU07</b>	Furniture	<b>PE09</b>	Personnel Services	<b>UN08</b>	Units & Components
<b>CL08</b>	Cleansers	<b>GL05</b>	Gloves	<b>PH05</b>	Pharmaceuticals	<b>UP05</b>	Upholstery
<b>CO05</b>	Collection Services	<b>GR05</b>	Group Health Plans	<b>PH08</b>	Photographic Equipment & Supplies	<b>VA05</b>	Vacuum Investing Machines
<b>CO07</b>	Communication Systems	<b>HA05</b>	Handcare Products & Services	<b>PI05</b>	Pins	<b>VA07</b>	Vacuum Units & Accessories
<b>CO09</b>	Composite Instruments & Accessories	<b>HA07</b>	Handpieces, Operating & Laboratory	<b>PI08</b>	Pit & Fissure Sealants	<b>VA10</b>	Varnishes
<b>CO11</b>	Composites	<b>IM05</b>	Implant Systems & Devices	<b>PL08</b>	Plating Equipment & Supplies	<b>VI05</b>	Vibrators & Accessories
<b>CO15</b>	Computer Hardware/Software	<b>IM07</b>	Impression Materials	<b>PO05</b>	Porcelain Products	<b>WA02</b>	Waterline Filtration Systems
<b>CO17</b>	Computer Imaging	<b>IN05</b>	Infection Control Products	<b>PO06</b>	Portable Delivery Systems	<b>WA05</b>	Wax Patterns, Molds/Removers
<b>CO10</b>	Cone Beam	<b>IN07</b>	Instruments (Hand), General	<b>PR05</b>	Practice Marketing Services	<b>WA07</b>	Waxes & Accessories
<b>CO20</b>	Continuing Education & Training	<b>IN09</b>	Instruments (Hand), Surgical	<b>PR07</b>	Practice Sales	<b>XR05</b>	X-Ray Film & Supplies
<b>CO21</b>	Cosmetic Restorations	<b>IN12</b>	Insurance	<b>PR10</b>	Preventive Dentistry Products	<b>XR06</b>	X-Ray Machines & Equipment
<b>CO22</b>	Cotton Products	<b>IN14</b>	Interior Decorating	<b>PR12</b>	Prophylaxis Angles & Kits	<b>XR07</b>	X-Ray Processors & Accessories
<b>CR05</b>	Crowns and/or Crown & Bridge Materials	<b>IN15</b>	Internet Services	<b>PR13</b>	Prophylaxis Brushes & Cups	<b>ZI03</b>	Zirconia
		<b>IN16</b>	Intraoral Video Cameras	<b>PR15</b>	Prophylaxis Materials		
		<b>IN18</b>	Investment Materials & Equipment	<b>PR17</b>	Protective Coverings		
		<b>IN19</b>	Investment Services	<b>PR21</b>	Prosthetic & Laboratory Supplies		

# GREATER NEW YORK

## November 25 - No

### Jacob K. Javits Co

#### Level 3 Exhibit

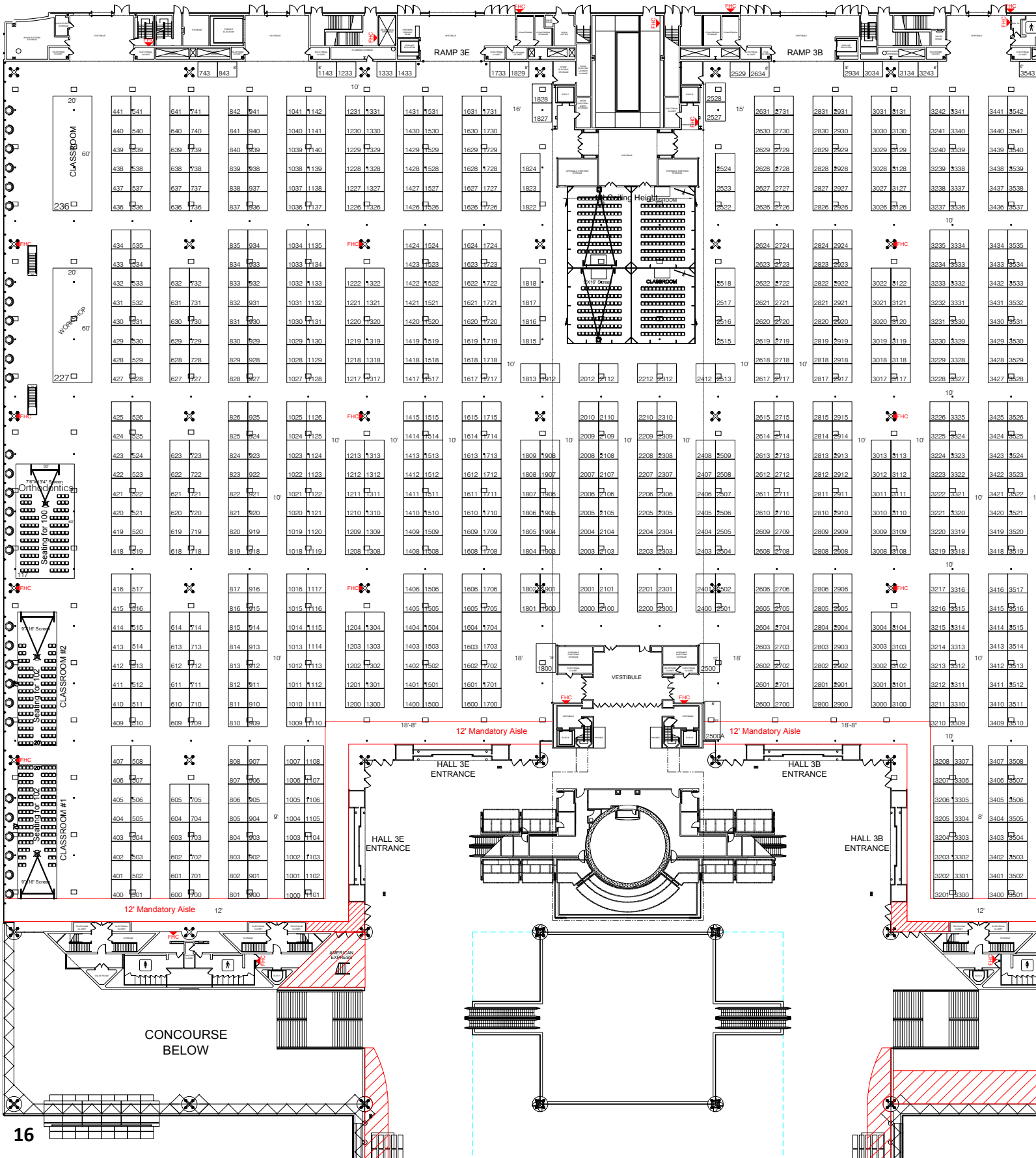



# K DENTAL MEETING

November 28, 2018

Convention Center

Hall Floor Plan

(Floor Plan subject to change.)

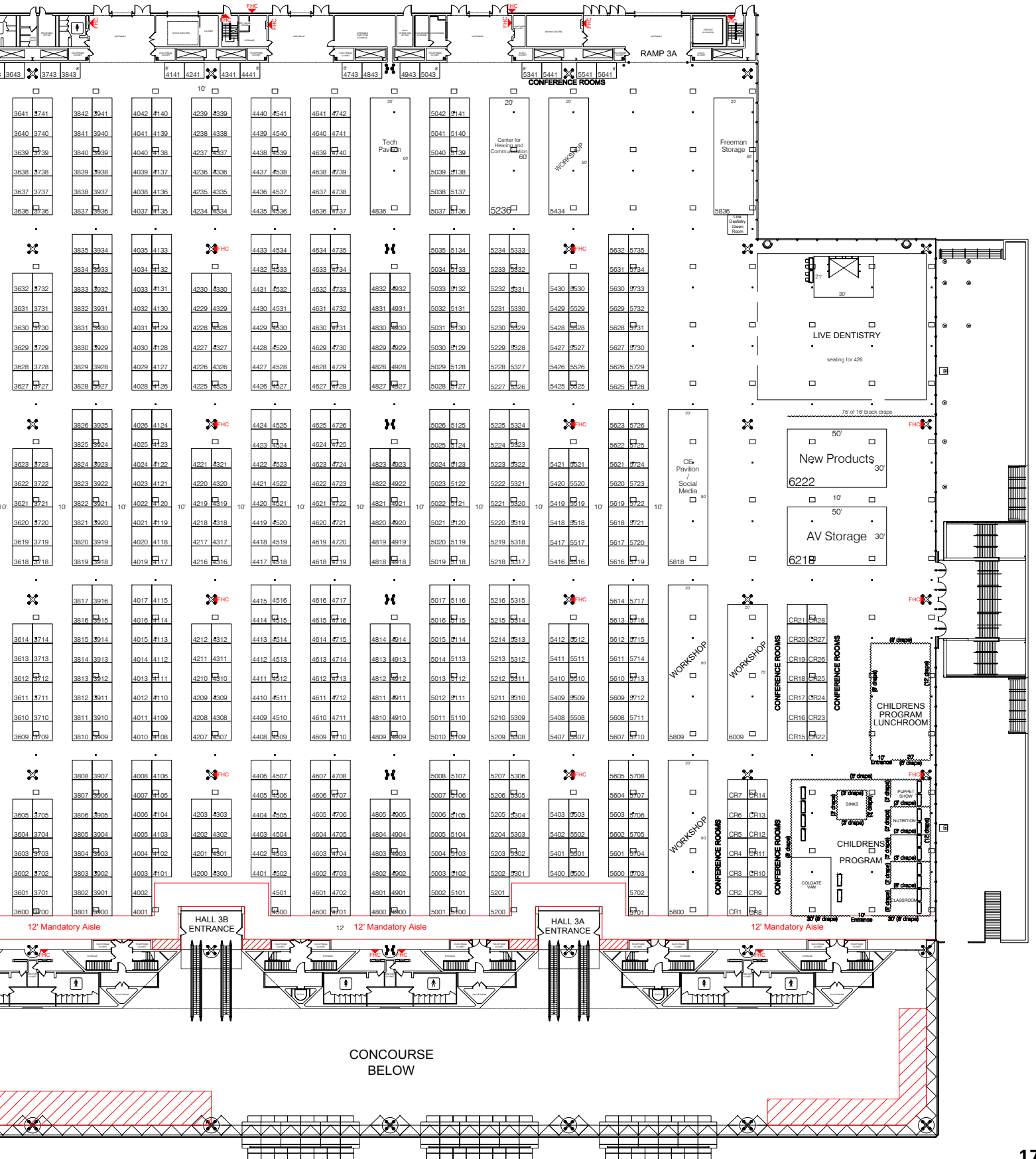

# 2018 Exhibitors' Calendar

## Checklist of Important Dates

<b>Tuesday, March 13</b>	<b>Deadline for return of Application/ Contract from priority mailing.</b>	<b>Tuesday, November 13</b>	<b>Last day for exhibit materials and equipment shipped by or on behalf of the Exhibitor for delivery at the Center for November 25 set-up to be received by Freeman.</b>
<b>Friday, June 1</b>	<b>Exhibitors cancelling before this date will be entitled to a full refund.</b>		
<b>Friday, July 13</b>	<b>Deadline for special electrical wiring.</b>	<b>Friday, November 23</b>	<b>10:00 A.M. Set up at Jacob K. Javits Convention Center begins.</b>
<b>Wednesday, August 1</b>	<b>No refunds or extensions beyond this date. Application/Contract made after this date must be accompanied by full payment.</b>	<b>Saturday, November 24</b>	<b>5:00 P.M. Entire exhibit, with all displays completely set up and ready for inspection.</b>
<b>Wednesday, August 1</b>	<b>Final balance of Exhibit Booth payment due.</b>	<b>Sunday, November 25</b>	<b>9:30 A.M. Exhibit Hall opens.</b>
<b>Wednesday, August 1</b>	<b>End of partial refund period, no refunds after this date.</b>	<b>Wednesday, November 28</b>	<b>5:00 P.M. Exhibit Hall closes. Dismantling of exhibits begins.</b>
<b>Friday, August 10</b>	<b>Exhibitors' Manual available on-line.</b>	<b>Thursday, November 29</b>	<b>9:00 P.M. Entire exhibits removed from Exhibit Hall 3E.</b>
<b>Wednesday, August 29</b>	<b>Deadline for the submission of the original Certificate of Insurance, and deadline for notification of intent to use an Exhibitor Appointed Contractor.</b>	<b>Friday, November 30</b>	<b>10:00 A.M. Entire exhibits removed from Exhibit Hall 3A/B/D.</b>
<b>Thursday, October 18</b>	<b>All finished banners must be received by Freeman.</b>		

## Free New Product Display

We are once again offering free space in the New Product and Technology Pavilion to our 2018 exhibitors. Don't miss the opportunity to have your newest product displayed at the 94th Greater New York Dental Meeting free of charge. This conveniently located pavilion will be easily accessible and visible to all attendees throughout the entire Meeting. Your product will be displayed along with your Company Name and booth number, so attendees can locate your booth on-site for additional information. This Pavilion space is limited and will be assigned on a first-come, first-placed basis. A Listing of new products will also be posted on our website for participating exhibitors.



# Sponsorship & Advertising Opportunities

## HIGHLIGHT YOUR COMPANY AND SALES OPPORTUNITIES... JOIN OUR SPONSORSHIP PROGRAM.

### **Early Sign Up Sponsorship & Advertising Discounts:**

- Sign up by March 1<sup>st</sup> and receive a 15% discount
- Sign up between March 2<sup>nd</sup> and April 2<sup>nd</sup> and receive a 10% discount

For more information or to reserve your sponsorship and advertising contact Ms. Dana Soltis, Sponsorship & Advertising Manager, at [dana@gnydm.com](mailto:dana@gnydm.com) or 212-398-6922. The GNYDM welcomes all innovative ideas!

We are looking forward to making the GNYDM your most successful event.

## SPONSORSHIPS AT-A-GLANCE

• Aisle Signs	Page 20	• Lanyards	Page 22
• Bags	Page 20	• “Live” Demonstration Arena Banner	Page 23
• Banners	Page 20	• “Live” Demonstration Arena - Commercial	Page 23
• Bathroom Stall Doors	Page 20	• “Live” Dentistry Arena Program - 2½ hours	Page 25
• Brochures (Multilanguage)	Page 27	• Multi-Rotation Banners	Page 27
• Celebrity Luncheon	Page 20	• Multi-Rotation Splash Screen	Page 27
• Charging Stations	Page 21	• Notebooks & Pens	Page 23
• Column Wraps	Page 21	• Pop to the Top	Page 27
• Concourse Banner 2-Sided	Page 20	• Push Notification	Page 27
• Education Registry Login Screen	Page 21	• Registration Area Demonstrations & Classroom	Page 23
• Escalator Runners	Page 21	• Scientific Poster Sessions	Page 25
• Floor Minders	Page 21	• Shuttle Bus Headrest Cover	Page 23
• Free Standing Product	Page 21	• Shuttle Bus Service	Page 23
• Free Standing Signs (2-Sided)	Page 21	• Staircase to the Crystal Palace	Page 24
• General Practice Residency Fair	Page 25	• Staircase to Education Wing	Page 24
• Health Screening Fair	Page 22	• Table Top Graphics	Page 24
• Hotel Keys	Page 22	• WiFi Connection	Page 24
• Individual Educational Programs	Page 25	• Window Advertising	Page 24
• International Reception	Page 22	• Workshops on the Exhibit Floor	Page 25
• Internet Café	Page 22		
• JumboTron Advertising	Page 22		

## DESIGN YOUR OWN SPONSORSHIP

# Sponsorship and Advertising

**BAGS**  
1 EXHIBITOR / \$20,950



Tote bags are of great demand to all dental professionals walking the Exhibit Floor. Have your logo and/or advertisement on one side and the Meeting logo on the other. 40,000 will be distributed to all of your designated attendee groups. Includes the cost of production.

**BANNERS OVER STAIRCASE**  
CONCOURSE SIDE... \$14,950  
EDUCATION SIDE... \$13,950



A two-sided banner (20' x 40') is placed over the grand staircase to the Crystal Palace Registration Area and Education Area. Sponsorship includes installation, teardown and Javits Center space rental, but does not include production costs.

**AISLE SIGNS - EXHIBIT HALL AISLES**  
\$15,000



Your company's name and logo will appear at the bottom of each aisle sign throughout the Exhibit Floor. Sponsorship does not include cost of production. Multiple year contract available.

**BATHROOM STALL DOORS**  
\$12,000



Capture the attention of all the attendees. Place fun and innovative 3M graphics in the bathrooms on the exhibit floor letting attendees know about your product and the location of your booth. Also included is a 1 meter sign at every door.

**BANNERS**  
\$9,875  
(MULTIPLE YEAR CONTRACTS AVAILABLE)



Banners can be placed throughout the Jacob K. Javits Convention Center, in the registration and educational areas. Sponsorship includes installation, teardown and Javits Center space rental, but does not include production costs. Call for available locations and sizes. For multi year contracts, GNYDM will store the banner.

**CELEBRITY LUNCHEON**  
(SPONSORSHIPS STARTING AT \$17,000)



Held on Monday, this traditional luncheon honors Presidents and Deans of Dental Organizations and schools throughout the world. A Celebrity speaker addresses the audience as a highlight of the event. Printed brochures are provided at each table, highlighting the speaker and sponsoring company. Sponsorship also includes a table at the luncheon for representatives of your company and the opportunity to distribute materials and/or giveaways. Signage and promotional materials including the Program & Exhibit Guide recognition are also included. Luncheon tickets are available for purchase by all attendees. Company recognition and pictures with the Celebrity prior to the luncheon are included.

# Sponsorship and Advertising



**CHARGING STATION**  
 1 STATION - \$3,950.00/2 STATIONS - \$5,900.00  
 3 STATIONS - \$8,900.00

Help attendees “get a charge” by sponsoring the mobile charging station located on the exhibit floor. Includes companies advertising message on the free standing charging station.



**ESCALATOR RUNNERS**  
 \$6,495 PER ESCALATOR (3 AVAILABLE)

Escalator Runners feature the sponsor’s message on a long banner running between the up and down escalators. Railing advertising also available on request.



**COLUMN WRAPS**  
 7,500.00 PER (LIMIT 2)

Located in prime, high-traffic locations, the Indoor Column Wraps are a great way to get noticed by buyers as they make their way through the registration lobby and to the exhibit halls. Wrap your brand on one of many available locations sure to make a BIG impact.



**FLOOR MINDERS**  
 7' X 7' DIAMOND - \$2,975/5' X 5' SQUARE...\$2,675

A 3M adhesive graphic can be placed on the floor near the registration area or the exhibit hall. Sponsorship includes installation, teardown and Javits Center space rental and production costs.



**EDUCATION REGISTRY LOGIN SCREEN**  
 \$10,975

Designated areas on the Exhibit Floor are available for attendees to record Continuing Education Credits using the barcode on their badge. Sponsors receive recognition on individual computer terminals, in Greater New York Dental Meeting publications, as the sponsor.



**FREE STANDING SIGNS/PRODUCTS**  
 2 SIDED - \$3,075 / PRODUCTS - \$3,975

Your Company’s advertisement or product is displayed near the registration area on free standing 38 1/2” x 87” signs or exhibit hall entrance area. Costs include fabrication, labor set-up and dismantling and Javits rental. Each additional panel variation - \$275/panel.

# Sponsorship and Advertising

## HEALTH SCREENING FAIR CALL FOR PRICING



Help sponsor our 3<sup>rd</sup> Annual FREE Health Screening Fair at the Greater New York Dental Meeting where attendees can receive free Eye Exam, Blood Pressure, Hearing, Diabetes Screening, Caries and Oral Cancer Screenings. If more information and details contact Dana Soltis at 212-398-6922 or [dana@gnydm.com](mailto:dana@gnydm.com).

## HOTEL KEYS \$9,950

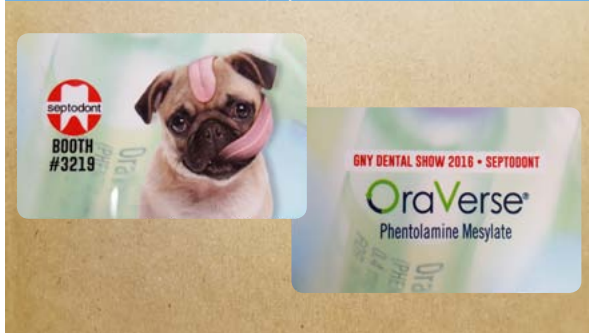

Your company's advertisement/logo displayed on the room keys at our headquarters hotel, the Marriott Marquis, Sheraton and Westin. Production costs are included.

## INTERNATIONAL RECEPTION \$9,800



The International Reception is an invitation-only event honoring our international guests following the completion of the first full exhibit day of the Meeting. Recognition is via signage and promotional material can be distributed. The Sponsor is encouraged to attend and be recognized. Held Sunday, November 25<sup>th</sup>, 5:30-7:00 pm at the Jacob K. Javits Convention Center. In 2016 there were over 600 attendees present at this event.

## INTERNET CAFÉ \$8,750



Located directly on the Exhibit Floor from Sunday through Wednesday, the Internet Café allows for all attendees to check personal emails and stay connected while visiting the Greater New York Dental Meeting. Sponsorship includes the rental of the computers, electric lines, T-1 lines, stands for the 8 computers and the appropriate space on the Exhibit Floor. The homepage on the computers can include your company's advertisement and booth number. Meter signs with your advertisement will be placed in the Café area.

## JUMBOTRON & TV ADVERTISING \$5,000 PER MINUTE



The Jacob Javits consists of (1) 600 sq. ft. LED JumboTron situated in the center of the Crystal Palace and 70+ 42" plasma TVs with audio and video located throughout 4 levels of the Javits. The same content goes to the JumboTron and TVs Saturday through Wednesday. Show off your company's products and services where all attendees can see your advertisement.

Your advertisement will play 1 min for each hour of the show, Saturday through Wednesday. You can also split the 1 min per hour for 15 sec x 4 times per hour or 30 sec x 2 times per hour.

## LANYARDS \$15,975



Every attendee at the Greater New York Dental Meeting must wear an identification badge. Supply us with approved lanyards and we will distribute them to all attendees. The badge holder kiosks are located on the registration level. Approximately 40,000. The Sponsoring company must supply the lanyards and have them approved to GNYDM standards.

# Sponsorship and Advertising

## "LIVE" DENTISTRY ARENA BANNERS 15' X 20' - \$7,000 (LIMITED TO 2 COMPANIES)



The banners are located on the northern wall of the exhibit hall in the "Live" Demonstration area. In addition, there are other highlights taking place in this area which attract attendees. Banners provided by the exhibitor. Greater New York Dental Meeting is responsible for the installation and dismantling. Limited to two companies.

## "LIVE" DENTISTRY ARENA COMMERCIAL \$5,000



Create a 60 second commercial and information advertisement to be played in our 550 seat "Live" Patient Arena for 4 days. Your Advertisement will run during intermission between 9:30 a.m. – 5:00 p.m. This opportunity is limited to 4 companies to give you more exposure.

## NOTEBOOKS & PENS \$8,000

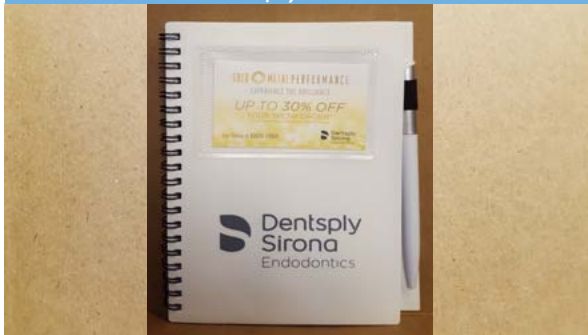

Your Company provides a notebook and pen for dental professionals at the Meeting. These books have your name and logo as well as the Greater New York Dental Meeting name and logo on the front cover. Product promotional literature can be inserted. The verbiage of the notebooks must be approved by the Greater New York Dental Meeting. They can be distributed in designated 1E Hall educational classrooms. This is an excellent way to get your Company's name in the forefront of dental education.

## REGISTRATION AREA DEMONSTRATIONS & CLASSROOM CALL FOR PRICING

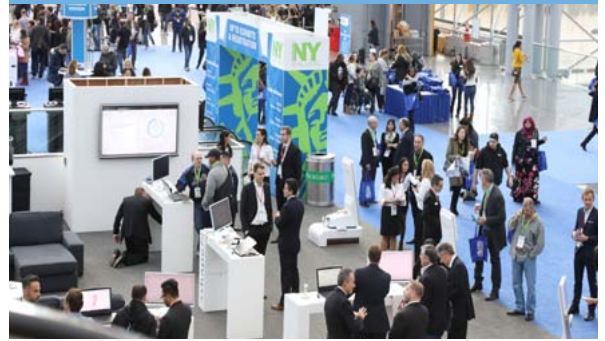

Show case your products or run educational events in this 35' x 35' space right next to the registration area. This Hi-Traffic area will allow attendees to see you when they Register and walk in the front doors. Hang a banner over your area so attendees can see it throughout the Javits Center.

## SHUTTLE BUS HEADREST COVERS \$9,295



The Sponsor's message is available on both sides of the headrest cover. Sponsorship includes production of a two-color design, installation and removal. Eight designated show buses will run continuously throughout the Meeting to and from the Jacob K. Javits Convention Center and Hotels.

## SHUTTLE BUS SERVICE 3 BUSES \$31,000 / 8 BUSES \$85,000



For six consecutive days, buses will operate from early morning until evening throughout New York City, transporting dental professionals between their Hotels and the Convention Center. Your advertisement will be seen not only by the dental community but by thousands of pedestrian consumers who live, work or are visiting New York City during the height of the festive holiday season.

As the Sponsor, your Company's name and/or message will appear on the side of buses, route signs in hotel lobbies, on flyers containing bus schedule information and in our Program & Exhibit Guide. Sponsorship includes cost of signage production, display and labor.

# Sponsorship and Advertising

**STAIRCASES TO THE  
REGISTRATION AREA... \$17,950  
EDUCATION AREA... \$13,500**



This eye catching advertisement allows your company to be the first attraction seen by attendees entering the Convention Center. 3M Ad graphics are placed on the risers of the staircase back of the main concourse staircase steps. Sponsorship includes cost of graphic production, installation, teardown and Javits Center space rental.

**TABLE TOP GRAPHICS  
\$3,048/4 TABLES**



Put your Company logo/ad on table tops located in our food court and cafes. Sponsorship includes installation, teardown and Javits Center space rental, and cost of production.

**WINDOW ADVERTISING  
DOOR PANEL / SIDE**



Placed eye-level, 2'x2' square 3M graphics on the glass doors along the entrance to the Crystal Palace. This includes installation, teardown, Javits Center space rental and cost of production. Minimum of eight. Double-sided available for an additional \$60 per panel.

\$8,950 package of 8	\$16,950 package of 16
\$12,950 package of 12	\$21,000 package of 20

**WIRELESS INTERNET CONNECTION  
\$19,000 PER DAY / \$78,000 - 4 DAYS**



Help Meeting attendees stay connected and keep up to the minute with annual meeting events. Wireless service provides attendees access to the Internet and e-mail, throughout the main areas of the Convention Center, via their personal laptops, iPad and mobile device. Included is an advertisement on the login screen that pops up every time someone logs in.

## SOCIAL MEDIA AD CAMPAIGNS WITH THE GREATER NEW YORK DENTAL MEETING!

Share new products, equipment and technology.  
Advertise your educational programs and speakers  
to reach national and international audiences.

For more information, contact Jayme Spicciatie - [jayme@gnydm.com](mailto:jayme@gnydm.com)





# Educational Sponsorship

## DENTAL HYGIENISTS/ASSISTANTS LECTURE SERIES - \$5,000

Sponsorship of the Dental Assistant & Hygiene Pavilion includes a choice of either a Full Day Seminar or Two Half Day or 4 quarter day Seminars for your dental team. The Cost is \$5,000.00 for the full day use of the classroom. Included in the sponsorship is signage throughout the exhibit floor, construction and audio visual set-up for the classroom. Your company is responsible for providing a speaker, speaker travel and transportation. One meter board will also be included with your advertisement for the day.



## SCIENTIFIC POSTER SESSIONS - \$5,975

The Scientific Poster Session is an annual Sunday event that brings together dentists, post graduate residents, new dentists, dental and hygiene students, hygienists and technicians from the United States and many international countries. This three hour session attracts attendees interested in research, dental procedural developments and technological advances. Sponsorship includes signage, recognition in our Program Guide, a table for brochures and your company representatives and refreshments.



## GENERAL PRACTICE RESIDENCY FAIR COLLATION - \$6,000

Held on Sunday, the Fair provides junior and senior dental students with the opportunity to gather information regarding available general practice residencies from representatives of over 60 hospital dental programs. With the growing importance of residency programs, this unique event is well-attended and provides your Company with exposure to the young graduating dentist.



Sponsorship includes: banners at the Fair area advertising your company as the sponsor, refreshments, a table within the Fair for the distribution of materials to attendees by your representative, appropriate signage promoting the event and Program Guide recognition. Sponsorship does not include production of insignia or logo placement on banners. Materials are allowed to be distributed by the sponsoring company.

## WORKSHOPS ON THE EXHIBIT FLOOR - \$3,675

A glass enclosed workshop seating 42 attendees is located right on the exhibit floor. This classroom is also highly visible to persons walking on the exhibit floor. Signage indicating the sponsoring companies name is placed adjacent to the workshop room. The sponsoring company is responsible for supplies and equipment and clinician package which includes (hotel, transportation, and speaker honorarium). Speaker and honorarium must be approved by the Organization Committee. If you need a speaker, one can be provided for you.



## 4<sup>TH</sup> ANNUAL GLOBAL ORTHODONTIC MEETING



The Greater New York Dental Meeting initiates its newest addition to its educational and exhibit program. Companies are encouraged to participate in this unique program. For additional information contact the Global Orthodontic Chairman, **Dr. Gail Schupak**; [orthodontics@gnydm.com](mailto:orthodontics@gnydm.com).

## 5<sup>TH</sup> ANNUAL WORLD IMPLANT EXPO

The Greater New York Dental Meeting again in 2018 will hold its World Implant EXPO which will focus on the sector of Implantology. The GNYDM will expand its exhibit floor to include increasing sales opportunities for companies involved with implant products, technology, bone replacement materials and equipment.



Companies are encouraged to participate in this unique opportunity. For additional information on the Implant EXPO, contact the Implant EXPO Chairman, **Dr. James H. Doundoulakis**; [implants@gnydm.com](mailto:implants@gnydm.com).

## INDIVIDUAL EDUCATION PROGRAMS (COSTS VARY AS PER PROGRAM)

Your Company can sponsor scientific sessions. You can suggest speakers who must be approved by our Education Committee, or we can provide them for you. Signage and Program Guide recognition are included.



## "LIVE" DENTISTRY ARENA - CONTACT FOR PRICING

An ultra modern High-Tech "Live Dentistry Arena" with seating for 550 will feature clinicians and exhibitors working with "live" patients to present the latest in new procedures and technology throughout the 4 days of the exhibition. It is located on the exhibit floor. Projected screens and LCD monitors surround the area.



## 2<sup>ND</sup> ANNUAL PEDIATRIC DENTISTRY SUMMIT

This program will benefit both pediatric dentists and general dentists. Attendees will learn new techniques and fresh approaches to the treatment of your young patients! For additional program information, contact **Dr. Lauro-Medrano Saldana** at [pEDIATRICS@gnydm.com](mailto:pEDIATRICS@gnydm.com)



## 2<sup>ND</sup> ANNUAL SLEEP APNEA SYMPOSIUM

Your company can sponsor a program to inform attendees the Latest Research and awareness in Dental Sleep Medicine. Attendees will learn how to establish Sleep protocols in their practice. Contact **Dr. Marc B. Gainor** at [doctorgainor@verizon.net](mailto:doctorgainor@verizon.net).



## 1<sup>ST</sup> ANNUAL 3D PRINTING & DIGITAL DENTISTRY CONFERENCE

New 3D Printing & Digital Dentistry Conference. Sponsor lectures and demonstrations on 3D Imaging Applications in Dentistry. For more information contact **Dr. William Bongiorno** at [CyberDent@mac.com](mailto:CyberDent@mac.com).





# ADVERTISING

## PROGRAM & EXHIBIT GUIDE SPECIFICATIONS

110,000 copies of the Program & Exhibit Guide are published annually and distributed to potential attendees. The Guide contains course synopses and speaker photographs, as well as an Exhibitor Directory, Product Index and Floor Plans. It encourages attendees to visit the Exhibit Hall and helps locate specific products and services. The Guide also serves as a year round reference source for use in the dental office for locating exhibitors and products. Take advantage of this opportunity to attract attendees to your booth and allow them to locate your telephone numbers and website address throughout the year.



**DEADLINES:** Your completed advertising contract and full payment, is due June 17, 2018. Advertising space will not be reserved without full payment. Cancellations will not be accepted. All artwork is due June 17, 2018. The Greater New York Dental Meeting is not responsible for reproduction quality.

### COVER AND PREFERRED POSITION RATES

Inside Cover Double Spread	\$12,695
Back Cover	\$10,895
First Page	\$7,900
Inside Back Cover	\$8,500
Opposite Table of Contents	\$6,975

**ONLY 4-COLOR ADS WILL BE ACCEPTED FOR THESE POSITIONS.**

### ADVERTISING RATES

Full Page	\$3,995
Half Page Horizontal	\$2,850

For special position requests other than "Cover and Preferred," there is an additional charge of \$1,000. Booth numbers will be stripped in free of charge. No additional charge for bleeds.

	Decimal (WxH)	Numerical (WxH)	Horizontal	Decimal (WxH)	Numerical (WxH)
Full Page before trim	8.625 x 11.125	8 $\frac{1}{2}$ x 11 $\frac{1}{8}$	Half Page before trim	8.625 x 5.625	8 $\frac{1}{2}$ x 5 $\frac{3}{8}$
Trimmed Size	8.5 x 10.875	8 $\frac{1}{2}$ x 10 $\frac{7}{8}$	Trimmed Size	8.5 x 5.5	8 $\frac{1}{2}$ x 5 $\frac{1}{2}$
Safety	8.125 x 10.5	8 $\frac{1}{8}$ x 10 $\frac{1}{2}$	Safety	8.125 x 5.125	8 $\frac{1}{8}$ x 5 $\frac{1}{4}$
Non-Bleed			Non-Bleed		
Full Page	8 x 10.375	8 x 10 $\frac{3}{4}$	Half Page	8 x 5.125	8 x 5 $\frac{1}{4}$

### ADVERTISING REQUIREMENTS:

Please prepare your advertisement for submission as a High-Res PDF, Photoshop, InDesign, Illustrator EPS or TIFF file. Advertisements created in Microsoft Word or other applications not mentioned above **are not** usable. If you use a MAC, **include** a PDF, TIFF or editable EPS file in addition to source files. All EPS files should have fonts converted to outlines. All images must be at least 300 dpi. All advertisements **must** use CMYK colors and be accompanied by a color proof and production contact information. Advertisements with dimensions differing from those listed under Advertising Dimensions are subject to a 10% additional charge.

## MULTILINGUAL BROCHURE



5,000 copies of this brochure, in seven languages, are made available to United States Embassies throughout the world. In addition, they are distributed at International Dental Meetings. The brochure contains general Meeting information, as well as, Hotel and Meeting registration forms.

### Closing Dates

Insertion order with full payment and artwork is due February 15, 2018. No cancellations are accepted.

### Mechanical Requirements

2 Ads available 4-Color only  
Single page .....

### Width

6"

### Height

9"

\$2,595

## EMAIL BLAST



Promote your product and company to the GNYDM email list of 70,000 with an email blast banner AD. The banner will be included on the bottom of the Attendee Blasts. Included with the banner a URL of your choice will be linked to the banner. - **\$1,000.00**

## THERE'S AN APP FOR THAT! (MOBILE APP ADVERTISING)



The Greater New York Dental Meeting Mobile App will provide sponsors with the opportunity for promotion through smartphone banner ads and multimedia advertising. Various locations are available call for options and pricing.

**Multi-Rotation Splash Screen - \$5,500.00 (Limited to 3 companies)**  
(1080 x 1920px) (780 x 1620 visual space plus 300px padding)

**Multi-Rotation Banners - \$3,500.00 (Limited to 3 companies)**  
(1024 x 160px) (32 x 5 aspect ratio)

**Pop to the Top - \$1,500.00**

Your company will appear at the top of the exhibitor listing with a sponsors ribbon.

**Push Notifications - \$2,500.00 for 5 (170 Characters)**

Your companies notification will be sent at a specific day and time.

**Scavenger Hunt - \$1,500.00**

The Scavenger Hunt Sponsorship is a fun and unique way to promote your company. Each attendee who downloads the APP will be tasked with visiting all participating sponsor booths to scan a QR code that will be given to your company - guaranteeing traffic flow to you. Attendees will be entered into a raffle to win a prize each day of the Meeting Sunday – Wednesday.



# GREATER NEW YORK DENTAL MEETING

## ADVERTISING CONTRACT

### GREATER NEW YORK DENTAL MEETING™

200 West 41st Street - Suite 800  
New York, New York 10036-7203  
Phone: (212) 398-6922 Fax: (212) 398-6934  
E-mail: [dana@gnydm.com](mailto:dana@gnydm.com)  
Website: [www.gnydm.com](http://www.gnydm.com)

### 94<sup>th</sup> Annual Session

November 23 – November 28, 2018  
Exhibit Dates:  
November 25 - November 28, 2018  
Jacob K. Javits Convention Center  
New York City, New York

**TYPE OR PRINT THIS ORDER FORM. SIGN AND RETURN COMPLETED FORM TO** (212) 398-6934. Have questions or need additional information? Contact Dana Soltis at (212) 398-6922 or [dana@gnydm.com](mailto:dana@gnydm.com)

Company Name \_\_\_\_\_  
Address \_\_\_\_\_ City, State/Country, Zip Code \_\_\_\_\_  
Company Email \_\_\_\_\_ Company Website \_\_\_\_\_  
Telephone ( ) \_\_\_\_\_ Fax \_\_\_\_\_  
Advertising Contact Person \_\_\_\_\_ Email \_\_\_\_\_  
Telephone \_\_\_\_\_ Fax \_\_\_\_\_  
Marketing Contact Person \_\_\_\_\_ Email \_\_\_\_\_  
Telephone \_\_\_\_\_ Fax \_\_\_\_\_

### PROGRAM & EXHIBIT GUIDE (PRINTED)

- Inside Cover Double Spread \$12,695
- Back Cover \$10,895
- Inside Back Cover \$8,500
- First Page \$7,900
- Opposite Table of Contents \$6,975
- Full Page \$3,995
- Half Page \$2,850

### ADVERTISING BROCHURE

- Multilanguage \$2,595

### MOBILE ADVERTISING

- Multi-Rotation Splash Screen \$5,500
- Multi-Rotation Banners \$3,500.00
- Pop to the Top \$750.00
- Push Notifications \$2,500
- Scavenger Hunt \$1,500

### ADVERTISING

- JumboTron Advertising \$5,000 per min
- Email Blast Banners \$1,000

### CONTRACTS RECEIVED WITHOUT FULL PAYMENT WILL NOT BE PROCESSED.

#### PAYMENT

All payments for advertising must be made by company check or credit card\* (\*plus a 3% convenience fee.) All contracts must be accompanied with full payment.

**All advertising are non-cancelable and non-refundable.** Material/art must be e-mailed or shipped to **Dana Soltis, [dana@gnydm.com](mailto:dana@gnydm.com)** to arrive by the specified due date. Artwork submitted after specified deadline will incur additional charges.

**GREATER NEW YORK DENTAL MEETING DOES NOT ASSUME ANY LIABILITY OR RESPONSIBILITY FOR ANY TYPOGRAPHICAL ERRORS, OMISSIONS OR INACCURACIES OF ANY KIND IN ANY OF ITS PUBLICATIONS.**

**WE AGREE TO ABIDE BY ALL RULES AND REGULATIONS GOVERNING THE MEETING AS PUBLISHED IN THE 2018 EXHIBITORS' PROSPECTUS AND SPONSORSHIP & ADVERTISING BROCHURE, WHICH ARE A PART OF THIS CONTRACT AS IF PUBLISHED HEREIN.**

AUTHORIZED SIGNATURE \_\_\_\_\_ TITLE \_\_\_\_\_ DATE \_\_\_\_\_

PRINT FULL NAME \_\_\_\_\_



# GREATER NEW YORK DENTAL MEETING

## SPONSORSHIP CONTRACT

94<sup>th</sup> Annual Session  
 November 23 – November 28, 2018  
 Exhibit Dates:  
 November 25 - November 28, 2018  
 Jacob K. Javits Convention Center  
 New York City, New York

GREATER NEW YORK DENTAL MEETING™  
 200 West 41st Street - Suite 800  
 New York, New York 10036-7203  
 Phone: (212) 398-6922 Fax: (212) 398-6934  
 E-mail: dana@gnydm.com  
 Website: www.gnydm.com

**TYPE OR PRINT THIS ORDER FORM. SIGN AND RETURN COMPLETED FORM TO (212) 398-6934.** Have questions or need additional information? Contact Dana Soltis at (212) 398-6922 or dana@gnydm.com

Company Name \_\_\_\_\_  
 Address \_\_\_\_\_ City, State/Country, Zip Code \_\_\_\_\_  
 Company Email \_\_\_\_\_ Company Website \_\_\_\_\_  
 Telephone ( ) \_\_\_\_\_ Fax \_\_\_\_\_  
 Sponsorship Contact Person \_\_\_\_\_ Email \_\_\_\_\_  
 Telephone \_\_\_\_\_ Fax \_\_\_\_\_  
 Marketing Contact Person \_\_\_\_\_ Email \_\_\_\_\_  
 Telephone \_\_\_\_\_ Fax \_\_\_\_\_

- |  |                       |  |                    |
|--|-----------------------|--|--------------------|
| <input type="checkbox"/> General Practice Residency Fair         | \$6,000               | <input type="checkbox"/> Free Standing Signs/Products                    | \$3,075/\$3,975    |
| <input type="checkbox"/> Individual Education Programs           | Varies                | <input type="checkbox"/> Hotel Keys                                      | \$9,950            |
| <input type="checkbox"/> Scientific Poster Sessions              | \$5,975               | <input type="checkbox"/> International Reception                         | \$9,800            |
| <input type="checkbox"/> "Live" Patient Demonstration            | Varies                | <input type="checkbox"/> Internet Café                                   | \$8,750            |
| <input type="checkbox"/> Learn and Lunch                         | \$18,500              | <input type="checkbox"/> JumboTron Advertising                           | \$5,000 per min    |
| <input type="checkbox"/> Workshops on the Exhibit Floor          | Varies                | <input type="checkbox"/> Laynards  | \$15,975           |
| <input type="checkbox"/> Dental Hygiene/Assistant Lecture Series | \$5,000               | <input type="checkbox"/> Live Dentistry Arena - Commercial               | \$5,000            |
| <input type="checkbox"/> World Implant EXPO                      | Varies                | <input type="checkbox"/> Notebooks & Pens                                | \$8,000            |
| <input type="checkbox"/> Global Orthodontic Meeting              | Varies                | <input type="checkbox"/> Registration Area Demonstrations<br>& Classroom | Call for pricing   |
| <input type="checkbox"/> After Hours Exhibit Floor Program       | \$3,500               | <input type="checkbox"/> Shuttle Bus Headrests                           | \$9,295            |
| <input type="checkbox"/> Aisle Signs                             | \$15,000              | <input type="checkbox"/> Staircase Graphics                              |                    |
| <input type="checkbox"/> Bags                                    | \$20,950              | <input type="checkbox"/> Registration Area                               | \$17,950           |
| <input type="checkbox"/> Banners                                 | \$9,875               | <input type="checkbox"/> Education Area                                  | \$13,500           |
| <input type="checkbox"/> Banners Over Staircases                 |                       | <input type="checkbox"/> Table Top Graphics                              | \$3,048 / 4 Tables |
| <input type="checkbox"/> Concourse Side                          | \$14,950              | <input type="checkbox"/> "Live" Dentistry Arena Banner                   |                    |
| <input type="checkbox"/> Education Side                          | \$13,950              | <input type="checkbox"/> 15' x 20'                                       | \$7,000            |
| <input type="checkbox"/> Bathroom Stall Doors                    | \$12,000              | <input type="checkbox"/> Window Advertising                              |                    |
| <input type="checkbox"/> Buses                                   | See description       | <input type="checkbox"/> Package of 8                                    | \$8,950            |
| <input type="checkbox"/> Celebrity Luncheon                      | \$17,000              | <input type="checkbox"/> Package of 12                                   | \$12,950           |
| <input type="checkbox"/> Charging Stations                       | See description       | <input type="checkbox"/> Package of 16                                   | \$16,950           |
| <input type="checkbox"/> Column Wrap                             | \$7,500               | <input type="checkbox"/> Package of 20                                   | \$21,000           |
| <input type="checkbox"/> Education Registry Login Screen         | \$10,000              | <input type="checkbox"/> WiFi  | See description    |
| <input type="checkbox"/> Escalator Runners                       | \$6,495 per escalator |  |                    |
| <input type="checkbox"/> Floor Minders                           |                       |  |                    |
| <input type="checkbox"/> 7' x 7' Diamond                         | \$2,975               |  |                    |
| <input type="checkbox"/> 5' x 5' Square                          | \$2,675               |  |                    |

**CONTRACTS RECEIVED WITHOUT FULL PAYMENT WILL NOT BE PROCESSED.**

**PAYMENT**

All payments for sponsorships must be made by company check or card\* (\*plus a 3% convenience fee.) All contracts must be accompanied with full payment.

**All sponsorships are non-cancelable and non-refundable.** Material/art must be e-mailed or shipped to Dana Soltis, dana@gnydm.com to arrive by the specified due date. Artwork submitted after specified deadline will incur additional charges.

**GREATER NEW YORK DENTAL MEETING DOES NOT ASSUME ANY LIABILITY OR RESPONSIBILITY FOR ANY TYPOGRAPHICAL ERRORS, OMISSIONS OR INACCURACIES OF ANY KIND IN ANY OF ITS PUBLICATIONS.**

**WE AGREE TO ABIDE BY ALL RULES AND REGULATIONS GOVERNING THE MEETING AS PUBLISHED IN THE 2018 EXHIBITORS' PROSPECTUS AND SPONSORSHIP & ADVERTISING BROCHURE, WHICH ARE A PART OF THIS CONTRACT AS IF PUBLISHED HEREIN.**

AUTHORIZED SIGNATURE \_\_\_\_\_ TITLE \_\_\_\_\_ DATE \_\_\_\_\_

PRINT FULL NAME \_\_\_\_\_



# GREATER NEW YORK DENTAL MEETING

## DAILY ONSITE ADVERTISING CONTRACT

**GREATER NEW YORK DENTAL MEETING™**  
200 West 41st Street - Suite 800  
New York, New York 10036-7203  
Phone: (212) 398-6922 Fax: (212) 398-6934  
E-mail: [dana@gnydm.com](mailto:dana@gnydm.com)  
Website: [www.gnydm.com](http://www.gnydm.com)

**94<sup>th</sup> Annual Session**  
**November 23 – November 28, 2018**  
**Exhibit Dates:**  
**November 25 - November 28, 2018**  
**Jacob K. Javits Convention Center**  
**New York City, New York**

**TYPE OR PRINT THIS ORDER FORM. SIGN AND RETURN COMPLETED FORM TO (212) 398-6934.** Have questions or need additional information? Contact Dana Soltis at (212) 398-6922 or [dana@gnydm.com](mailto:dana@gnydm.com)

Company Name \_\_\_\_\_  
Address \_\_\_\_\_ City, State/Country, Zip Code \_\_\_\_\_  
Company Email \_\_\_\_\_ Company Website \_\_\_\_\_  
Telephone ( ) \_\_\_\_\_ Fax \_\_\_\_\_  
Advertising Contact Person \_\_\_\_\_ Email \_\_\_\_\_  
Telephone \_\_\_\_\_ Fax \_\_\_\_\_  
Marketing Contact Person \_\_\_\_\_ Email \_\_\_\_\_  
Telephone \_\_\_\_\_ Fax \_\_\_\_\_

### WORLD SHOW DAILY

- Inside Front Cover + (Includes 500 Word Article) \$8,750.00
- Inside Back Cover + (Includes 500 Word Article) \$8,550.00
- Full Page + (Includes 500 Word Article) \$6,500.00
- 1/2 Page Advertisement \$3,950.00
- 1/4 Page Advertisement \$2,200.00
- Change Ads Each Day \$500.00

**CONTRACTS RECEIVED WITHOUT FULL PAYMENT WILL NOT BE PROCESSED.**

#### PAYMENT

All payments for advertising in the Daily must be made by company check or card\* (\*plus a 3% convenience fee.) All contracts must be accompanied with full payment.

**All advertising are non-cancelable and non-refundable.** Material/art must be e-mailed or shipped to **Dana Soltis, [dana@gnydm.com](mailto:dana@gnydm.com)** to arrive by the specified due date. Artwork submitted after specified deadline will incur additional charges.

**GREATER NEW YORK DENTAL MEETING DOES NOT ASSUME ANY LIABILITY OR RESPONSIBILITY FOR ANY TYPOGRAPHICAL ERRORS, OMISSIONS OR INACCURACIES OF ANY KIND IN ANY OF ITS PUBLICATIONS.**

**WE AGREE TO ABIDE BY ALL RULES AND REGULATIONS GOVERNING THE MEETING AS PUBLISHED IN THE 2018 EXHIBITORS' PROSPECTUS AND SPONSORSHIP & ADVERTISING BROCHURE, WHICH ARE A PART OF THIS CONTRACT AS IF PUBLISHED HEREIN.**

AUTHORIZED SIGNATURE \_\_\_\_\_ TITLE \_\_\_\_\_ DATE \_\_\_\_\_

PRINT FULL NAME \_\_\_\_\_



# MARK YOUR CALENDAR



**GREATER**  
**NY**  
DENTAL MEETING  
**2 0 1 9**

---

THE LARGEST DENTAL MEETING/EXHIBITION/CONGRESS IN THE UNITED STATES  
HELD AT THE  
JACOB K. JAVITS CONVENTION CENTER, NEW YORK CITY

---

## FUTURE MEETING DATES

**2019**

MEETING DATES:  
NOVEMBER 29-DECEMBER 4

EXHIBIT DATES:  
DECEMBER 1-4

**2020**

MEETING DATES:  
NOVEMBER 27-DECEMBER 2

EXHIBIT DATES:  
NOVEMBER 29-DECEMBER 2

**2021**

MEETING DATES:  
NOVEMBER 26-DECEMBER 1

EXHIBIT DATES:  
NOVEMBER 28-DECEMBER 1

**\*NO PRE-REGISTRATION FEE\***

**WWW.GNYDM.COM**