

IS 13828 : 1993

(Reaffirmed 1998)

भारतीय मानक

अल्प सामर्थ्य चिनाई इमारतों की भूकम्प प्रतिरोधता में
सुधार—मार्गदर्शी सिद्धान्त

Indian Standard

IMPROVING EARTHQUAKE RESISTANCE OF
LOW STRENGTH MASONRY BUILDINGS —
GUIDELINES

UDC 699.841

© BIS 1993

BUREAU OF INDIAN STANDARDS
MANAK BHAVAN, 9 BAHADUR SHAH ZAFAR MARG
NEW DELHI 110002

August 1993

Price Group 6

FOREWORD

This Indian Standard was adopted by the Bureau of Indian Standards, after the draft finalized by the Earthquake Engineering Sectional Committee had been approved by the Civil Engineering Division Council.

Himalayan-Naga Lushai region, Indo-Gangetic Plain, Western India and Kutch and Kathiawar regions are geologically unstable parts of the country and some devastating earthquakes of the world have occurred there. A major part of the peninsular India, has also been visited by moderate earthquakes, but these were relatively few in number and had considerably lesser intensity. It has been a long felt need to rationalize the earthquake resistant design and construction of structures taking into account seismic data from studies of these Indian earthquakes, particularly in view of the heavy construction programme at present all over the country. It is to serve this purpose that IS 1893 : 1984 'Criteria for earthquake resistant design of structures' was prepared. It lays down the seismic zones, the basic seismic coefficients and other factors and criteria for various structures. As an adjunct to IS 1893, IS 4326 'Code of practice for earthquake resistant design and construction of buildings' was prepared in 1967 and revised in 1976. This contained some recommendations for low strength brick and stone buildings. Earthquake damages to such buildings in Himachal Pradesh, North Bihar and Hill districts of Uttar Pradesh emphasized the need to expand these provisions. In order to assign the subject the importance it demanded in the context of prevalence of such buildings in the seismic zones. It was therefore considered appropriate to issue a separate standard on the subject. It is naturally tied to IS 1893 in view of the seismic zones and coefficients. It will be useful to read this standard along with IS 4326.

The Sectional Committee responsible for the preparation of this standard has taken into consideration the views of all who are interested in this field and has related the standard to the prevailing practices in the country. Due weightage has also been given to the need for international co-ordination among the standards and practices prevailing in different countries of the world.

The Committee responsible for the preparation of this standard is given at Annex A.

In the preparation of this standard, the publication 'Guidelines for earthquake resistant non-engineered construction', published by the International Association for Earthquake Engineering, Tokyo, October 1986, has been freely referred to.

Indian Standard

IMPROVING EARTHQUAKE RESISTANCE OF LOW STRENGTH MASONRY BUILDINGS — GUIDELINES

1 SCOPE

1.1 This standard covers the special features of design and construction for improving earthquake resistance of buildings of low-strength masonry.

1.1.1 The provisions of this standard are applicable in seismic zones III to V. No special provisions are considered necessary for buildings in seismic zones I and II.

1.1.2 The various provisions of IS 4326 : 1993 regarding general principles, special construction features, types of construction, categories of buildings and masonry construction with rectangular masonry units are generally applicable to the masonry buildings of low strength dealt with in this standard. There are however certain restrictions, exceptions and additional details which are specifically included herein. For completeness however all necessary portions are repeated here.

NOTE — Attention is hereby drawn to the fact that low-strength masonry as dealt with herein will neither qualify as engineered construction nor totally free from collapse in the severe seismic intensities VIII or IX. However, inclusion of special seismic design and construction features provided herein will raise their seismic resistance appreciably, reducing greatly the chances of collapse even in such seismic intensities.

2 REFERENCES

The following Indian Standards are necessary adjuncts to this standard:

<i>IS No.</i>	<i>Title</i>
1597 (Part 1) : 1967	Code of practice for construction of stone masonry : Part 1 Rubble stone masonry
1893 : 1984	Criteria for earthquake resistant design of structures (<i>first revision</i>)
1904 : 1984	Code of practice for design and construction of foundations in soils : General requirements
4326 : 1993	Code of practice for earthquake resistant design and construction of buildings (<i>second revision</i>)

3 TERMINOLOGY

3.0 For the purpose of this standard, the following definitions shall apply.

3.1 Low Strength Masonry

Includes fired brick work laid in clay mud mortar and random rubble; uncoursed, undressed or semi-dressed stone masonry in weak mortars; such as cement sand, lime-sand and clay mud.

3.2 Centre of Rigidity

The point in a structure where a lateral force shall be applied to produce equal deflections of its components at any one level in any particular direction.

3.3 Shear Wall

A wall designed to resist lateral force in its own plane.

3.4 Box System

A bearing wall structure without a space frame the horizontal forces being resisted by the walls acting as shear walls.

3.5 Band

A reinforced concrete, reinforced brick or wooden runner provided horizontally in the walls to tie them together, and to impart horizontal bending strength in them.

3.6 Seismic Zone and Seismic Coefficient

The seismic zones I to V as classified and the corresponding basic seismic coefficient α_0 , as specified in IS 1893 : 1984.

3.7 Design Seismic Coefficient (α_h)

The value of horizontal seismic coefficient computed taking into account the soil foundation system and the importance factor as specified in 3.4.2.3(a) of IS 1893 : 1984.

3.8 Concrete Grades

28 days crushing strength of concrete cubes of 150 mm side in MPa, for example, for M15 grade concrete crushing strength 15 MPa.

4 GENERAL PRINCIPLES

4.0 General

The general principles given in 4.1 to 4.5 should be observed in the construction of buildings for improving their earthquake resistance.

4.1 Lightness

Since the earthquake force is a function of mass, the building should be as light as possible consistent with structural safety and functional requirements. Roofs and upper storeys of buildings in particular should be designed as light as possible.

4.2 Continuity of Construction

4.2.1 As far as possible, all parts of the building should be tied together in such a manner that the building acts as one unit.

4.2.2 For integral action of building, roof and floor slabs should be continuous throughout as far as possible.

4.2.3 Additions and alterations to the structures should be accompanied by the provision of positive measures to establish continuity between the existing and the new construction.

4.3 Projecting and Suspended Parts

4.3.1 Projecting parts should be avoided as far as possible. If the projecting parts cannot be avoided, they should be properly reinforced and firmly tied to the main structure and their design should be in accordance with IS 1893 : 1984.

NOTE — In cases where stability of projecting parts against overturning is achieved by counterweight in the form of wall, slab etc, the overturning should be checked by increasing the weight of the projecting part and decreasing the weight of stabilizing mass simultaneously in accordance with the vertical seismic coefficient specified in 4.4.2 of IS 1893 : 1984.

4.3.2 Ceiling plaster should preferably be avoided. When it is unavoidable, the plaster should be as thin as possible.

4.3.3 Suspended ceiling should be avoided as far as possible. Where provided, they should be light and adequately framed and secured.

4.4 Shape of Building

In order to minimize torsion, the building should have a simple rectangular plan and be symmetrical both with respect to mass and rigidity so that the centres of mass and rigidity of the building coincide with each other. It will be desirable to use separate blocks of rectangular shape particularly in seismic zones V and IV.

NOTE — For small buildings, minor asymmetry in plan and elevation may be ignored. Designing such buildings against torsion may be difficult and uncertain.

4.5 Fire Safety

Fire frequently follows an earthquake and therefore buildings should be constructed to make them fire resistant in accordance with the provisions of relevant Indian Standards for fire safety.

5 SPECIAL CONSTRUCTION FEATURES

5.1 Foundations

5.1.1 For the design of foundations, the provisions of IS 1904 : 1986 in conjunction with IS 1893 : 1984 shall generally be followed.

5.1.2 The subgrade below the entire area of the building should preferably be of the same type of the soil. Wherever this is not possible, the buildings should preferably be separated into units and then the units should be located separately.

5.1.3 Loose fine sand soft silt and expansive clays should be avoided. If unavoidable the following measures may be taken to improve the soil on which the foundation of the building may rest:

- a) Sand piling/under reamed piling/stone columns, etc.
- b) Soil stabilization.

5.2 Roofs and Floors

5.2.1 Flat roof or floor should not preferably be made of tiles or ordinary bricks supported on steel, timber or reinforced concrete joists, nor they shall be of a type which in the event of an earthquake is likely to be loosened and parts or all of which may fall. If this type of construction cannot be avoided, the joists should be blocked at ends and bridged at intervals such that their spacing is not altered during an earthquake.

5.2.1.1 For pitched roofs, corrugated iron or asbestos sheets should be used in preference to country, Allahabad or Mangalore tiles or other loose roofing units. All roofing materials shall be properly tied to the supporting members. Heavy roofing materials should generally be avoided.

5.2.2 Pent Roofs

5.2.2.1 All roof trusses should be supported on and fixed to timber band reinforced concrete band or reinforced brick band. The holding down bolts should have adequate length as required for earthquake and wind forces.

Where a trussed roof adjoins a masonry gable, the ends of the purlins should be carried on and secured to a plate or bearer which should be adequately bolted to timber reinforced concrete or reinforced brick band at the top of gable end masonry.

5.2.2.2 At tie level, all the trusses and the gable end should be provided with diagonal braces in plan so as to transmit the lateral shear due to earthquake force to the gable walls acting as shear walls.

5.2.3 Jack Arches

Jack arched roofs or floors where used should be provided with mild steel ties in all spans along-with diagonal braces in plan to ensure diaphragm actions.

5.3 Staircases

5.3.1 The interconnection of the stairs with the adjacent floors should be appropriately treated by providing sliding joints at the stairs to eliminate their bracing effect on the floors. Ladders may be made fixed at one end and freely resting at the other.

5.3.2 Built-in Staircase

When stairs are built monolithically with floors, they can be protected against damage by providing rigid walls at the stair opening. The walls enclosing the staircase should extend through the entire height of the stairs and to the building foundations.

6 BOX TYPE CONSTRUCTION

This type of construction consists of prefabricated or *in-situ* masonry wall along with both the axes of the building. The walls support vertical loads and also act as shear walls for horizontal loads acting in any direction. All traditional masonry construction falls under this category. In prefabricated wall construction, attention should be paid to the connections between wall panels so that transfer of shear between them is ensured.

7 CATEGORIES OF BUILDINGS

For the purpose of specifying the earthquake resisting features, the buildings, have been categorised in five categories A to E, as given in Table 1, based on the value of α_h , given by:

$$\alpha_h = \alpha_0 I \beta$$

where

α_h = design seismic coefficient for the building,

α_0 = basic seismic coefficient for the seismic zone in which the building is located (see Table 2 of IS 1893 : 1984),

I = importance factor applicable to the building (see 3.4.2.3 of IS 1893 : 1984), and

β = soil foundation factor (see 3.4.2.3 and Table 3 of IS 1893 : 1984).

8 LOW STRENGTH MASONRY CONSTRUCTION

8.1 General

8.1.1 Two types of construction are included herein, namely:

- a) Brick construction using weak mortar, and
- b) Random rubble and half-dressed stone masonry construction using different mortars such as clay mud lime-sand and cement sand.

Table 1 Building Categories for Earthquake Resisting Features
(Clause 7)

Category	Range of α_h
A	0.04 to less than 0.05
B	0.05 to 0.06 (both inclusive)
C	More than 0.06 but less than 0.08
D	0.08 to less than 0.12
E	More than 0.12

NOTE — Low-strength masonry shall not be used for category E.

8.1.2 These constructions should not be permitted for important buildings with $I \geq 1.5$ and should preferably be avoided for building category D (see Table 1).

8.1.3 It will be useful to provide damp-proof course at plinth level to stop the rise of pore water into the superstructure.

8.1.4 Precautions should be taken to keep the rain water away from soaking into the wall so that the mortar is not softened due to wetness. An effective way is to take out roof projections beyond the walls by about 500 mm.

8.1.5 Use of a water-proof plaster on outside face of walls will enhance the life of the building and maintain its strength at the time of earthquake as well.

8.1.6 Ignoring tensile strength, free standing walls should be checked against overturning under the action of design seismic coefficient, α_h , allowing for a factor of safety of 1.5.

8.2 Brickwork in Weak Mortars

8.2.1 The fired bricks should have a compressive strength not less than 3.5 MPa. Strength of bricks and wall thickness should be selected for the total building height.

8.2.2 The mortar should be lime-sand (1 : 3) or clay mud of good quality. Where horizontal steel is used between courses, cement-sand mortar (1 : 3) should be used with thickness so as to cover the steel with 6 mm mortar above and below it. Where vertical steel is used, the surrounding brickwork of 1×1 or $1\frac{1}{2} \times 1\frac{1}{2}$

brick size depending on wall thickness should preferably be built using 1 : 6 cement-sand mortar.

8.2.3 The minimum wall thickness shall be one brick in one storey construction and one brick in top storey and $1\frac{1}{2}$ brick in bottom storeys of up to three storey construction. It should also not be less than $1/16$ of the length of wall between two consecutive perpendicular walls.

8.2.4 The height of the building shall be restricted to the following, where each storey height shall not exceed 3.0 m:

For Categories A, B and C — three storeys with flat roof; and two storeys plus attic for pitched roof.

For Category D — two storeys with flat roof; and one storey plus attic for pitched roof.

8.2.5 Special Bond in Brick Walls

For achieving full strength of masonry, the usual bonds specified for masonry should be followed so that the vertical joints are broken properly from course to course. To obtain full bond between perpendicular walls, it is necessary to make a sloping (stepped) joint by making the corners first to a height of 600 mm and then building the wall in between them. Otherwise the toothed joint should be made in both the walls, alternately in lifts of about 450 mm (see Fig. 1).

8.3 Stone Masonry (Random Rubble or Half-Dressed)

8.3.1 The construction of stone masonry of random rubble or dressed stone type should generally follow IS 1597 (Part 1) : 1967.

8.3.2 The mortar should be cement-sand (1 : 6), lime-sand (1 : 3) or clay mud of good quality.

8.3.3 The wall thickness 't' should not be larger than 450 mm. Preferably it should be about 350 mm, and the stones on the inner and outer wythes should be interlocked with each other.

NOTE — If the two wythes are not interlocked, they tend to delaminate during ground shaking bulge apart (see Fig. 2) and buckle separately under vertical load leading to complete collapse of the wall and the building.

8.3.4 The masonry should preferably be brought to courses at not more than 600 mm lift.

8.3.5 'Through' stones of full length equal to wall thickness should be used in every 600 mm lift at not more than 1.2 m apart horizontally. If full length stones are not available, stones in pairs each of about $3/4$ of the wall thickness may be used in place of one full length stone so as to provide an overlap between them (see Fig. 3).

8.3.6 In place of 'through' stones, 'bonding elements' of steel bars 8 to 10 mm dia bent to S-shape or as hooked links may be used with a cover of 25 mm from each face of the wall (see Fig. 3). Alternatively, wood bars of 38 mm x 38 mm cross section or concrete bars of 50 mm x 50 mm section with an 8 mm dia rod placed centrally may be used in place of 'through' stones. The wood should be well treated with preservative so that it is durable against weathering and insect action.

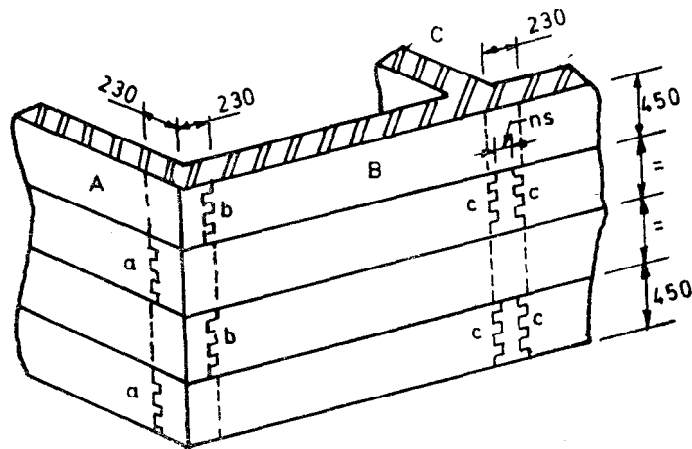

a, b, c = Toothed joints in wall A, B, and C

All dimensions in millimetres.

FIG. 1 ALTERNATING TOOTHED JOINTS IN WALLS AT CORNER AND T-JUNCTION

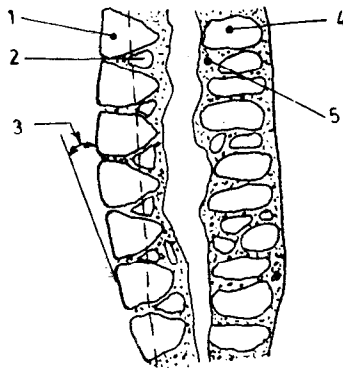

1. Half-dressed conical stone, 2. Small alignment stone, 3. Rotation of Wythe, 4. Random rubble, 5. Mud or weak lime mortar.

FIG. 2 WALL DELAMINATED WITH BUCKLED WYTHES

8.3.7 Use of 'bonding' elements of adequate length should also be made at corners and junctions of walls to break the vertical joints and provide bonding between perpendicular walls.

8.3.8 Height of the stone masonry walls (random rubble or half-dressed) should be restricted as follows, with storey height to be kept 3.0 m maximum, and span of walls between cross walls to be limited to 5.0 m:

- For categories A and B — Two storeys with flat roof or one storey plus attic, if walls are built in lime-sand or mud mortar; and one storey higher if walls are built in cement-sand 1 : 6 mortar.
- For categories C and D — Two storeys with flat roof or two storeys plus attic for pitched roof, if walls are built in 1 : 6 cement mortar; and one storey with flat roof or one storey plus attic, if walls are built in lime-sand or mud mortar, respectively.

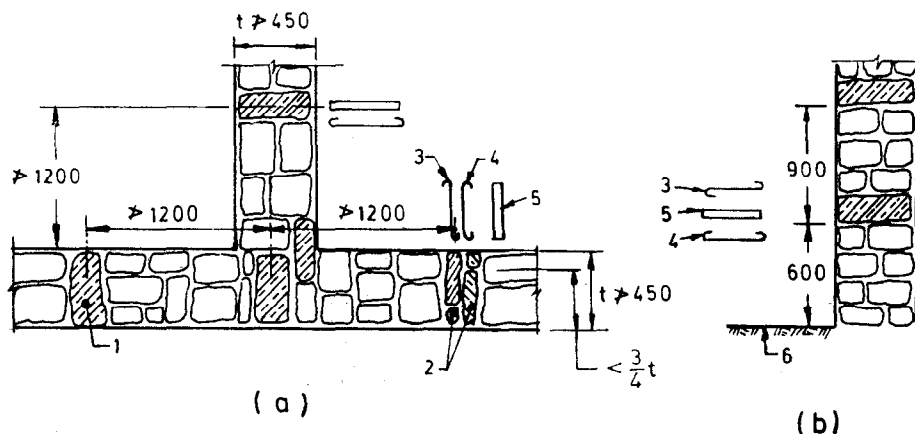

1. Through stone, 2. Pair of overlapping stone, 3. S-Shape tie, 4. Hooked tie, 5. Wood plank, 6. Floor level.

(a) Sectional plan of wall (b) Cross-section of wall
All dimensions in millimetres.

FIG. 3 THROUGH STONE AND BOND ELEMENTS

8.3.9 If walls longer than 5 m are needed, buttresses may be used at intermediate points not farther apart than 4.0 m. The size of the buttress be kept of uniform thickness. Top width should be equal to the thickness of main wall, t , and the base width equal to one sixth of wall height.

8.4 Opening in Bearing Walls

8.4.1 Door and window openings in walls reduce their lateral load resistance and hence should preferably, be small and more centrally located. The size and position of openings shall be as given in Table 2 and Fig. 4.

8.4.2 Openings in any storey shall preferably have their top at the same level so that a continuous band could be provided over them including the lintels throughout the building.

8.4.3 Where openings do not comply with the guidelines of Table 2, they should be strengthened by providing reinforced concrete lining as shown in Fig. 5 with 2 high strength deformed (H S D) bars of 8 mm dia.

8.4.4 The use of arches to span over the openings is a source of weakness and shall be avoided, otherwise, steel ties should be provided.

8.5 Seismic Strengthening Arrangements

8.5.1 All buildings to be constructed of masonry shall be strengthened by the methods as specified for various categories of buildings, listed in Table 3, and detailed in subsequent clauses. Fig. 6 and 7 show, schematically, the overall strengthening arrangements to be adopted for category D buildings, which consist of horizontal bands of reinforcement at critical levels and vertical reinforcing bars at corners and junctions of walls.

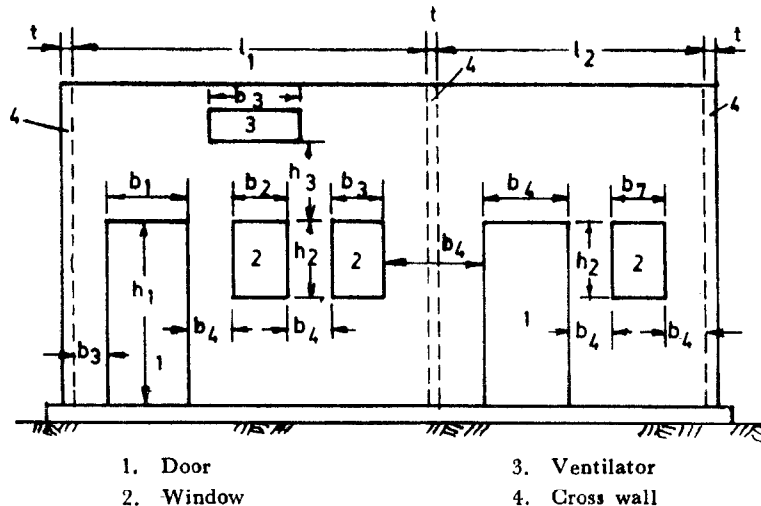

FIG. 4 DIMENSIONS OF OPENINGS AND PIERS FOR RECOMMENDATIONS IN TABLE 2

Table 2 Size and Position of Openings in Bearing Walls (see Fig. 4)
(Clauses 8.4.1 and 8.4.3)

Description	Building Category	
	A, B & C	D
i) Distance b_5 from the inside corner of outside wall, <i>Min</i>	230 mm	600 mm
ii) Total length of openings. ratio; <i>Max</i> : ($b_1 + b_2 + b_3$) / l_1 or ($b_6 + b_7$) / l_2 — one storeyed building	0.46	0.42
— 2 & 3 storeyed building	0.37	0.33
iii) Pier width between consecutive openings b_4	450 mm	560 mm
iv) Vertical distance between two openings one above the other, h_3 , <i>Min</i>	600 mm	600 mm

Table 3 Strengthening Arrangements Recommended for Low Strength Masonry Buildings
(Clause 8.5.1)

Building Category	Number of Storeys	Strengthening to be Provided
(1)	(2)	(3)
A	1 and 2 3	c, f b, c, f, g
B	1 and 2 3	b, c, f, g b, c, d, f, g,
C	1 2 and 3	b, c, f, g b, c, d, f, g
D	1 and 2	b, c, d, f, g

Strengthening Method

- b — Lintel band (see 8.5.2)
- c — Roof band and gable band where necessary (see 8.5.3 and 8.5.4)
- d — Vertical steel at corners and junctions of walls (see 8.5.7)
- f — Bracing in plan at tie level of pitched roofs (see 5.2.2.2)
- g — Plinth band where necessary (see 8.5.6)

NOTE — For building of category B in two storeys, constructed with stone masonry in weak mortar, it will be desirable to provide vertical steel of 10 mm dia in both storeys.

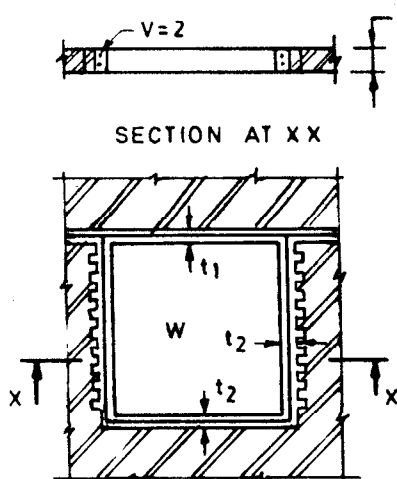
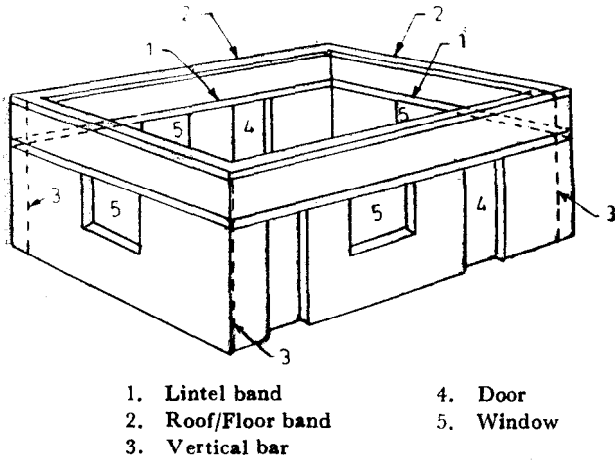

FIG. 5 STRENGTHENING MASONRY AROUND OPENING

8.5.2 Lintel band is a band (see 3.5) provided at lintel level on all internal and external longitudinal as well as cross walls except partition walls. The details of the band are given in 8.5.5.

8.5.3 Roof band is a band (see 3.5) provided immediately below the roof or floors. The details of the band are given in 8.5.5. Such a band need not be provided underneath reinforced concrete or reinforced brick slabs resting on bearing walls, provided that the slabs cover the width of end walls fully.



- | | |
|--------------------|-----------|
| 1. Lintel band | 4. Door |
| 2. Roof/Floor band | 5. Window |
| 3. Vertical bar | |

FIG. 6 OVERALL ARRANGEMENT OF REINFORCING LOW STRENGTH MASONRY BUILDINGS

8.5.4 Gable band is a band provided at the top of gable masonry below the purlins. The details of the band are given in 8.5.5. This band shall be made continuous with the roof band at the eave level.

8.5.5 Details of Band

8.5.5.1 Reinforced band

The band should be made of reinforced concrete of grade not leaner than M15 or reinforced brickwork in cement mortar not leaner than 1 : 3. The

bands should be of the full width of the wall, not less than 75 mm in depth and should be reinforced with 2 HSD bars 8 mm dia and held in position by 6 mm dia bar links, installed at 150 mm apart as shown in Fig. 8.

NOTES

1 In coastal areas, the concrete grade shall be M20 and the filling mortar of 1 : 3 ratio (cement-sand) with water proofing admixture.

2 In case of reinforced brickwork, the thickness of joints containing steel bars should be increased to 20 mm so as to have a minimum mortar cover of 6 mm around the bar. In bands of reinforced brickwork, the area of steel provided should be equal to that specified above for reinforced concrete bands.

3 For full integrity of walls at corners and junctions of walls and effective horizontal bending resistance of bands, continuity of reinforcement is essential. The details as shown in Fig. 8 are recommended.

8.5.5.2 Wooden band

As an alternative to reinforced band, the lintel band could be provided using wood beams in one or two parallel pieces with cross elements as shown in Fig. 9.

8.5.6 Plinth band is a band provided at plinth level of walls on top of the foundation wall. This is to be provided where strip footings of masonry (other than reinforced concrete or reinforced masonry) are used and the soil is either soft or uneven in its properties as frequently happens in hill tracts. Where used, its section may be kept same as in 8.5.5.1. This band serves as damp proof course as well.

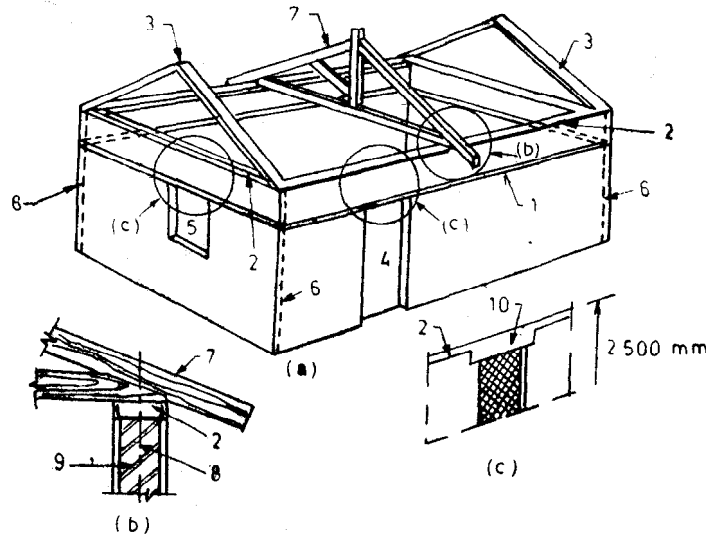

- | | |
|------------------------------|---|
| 1. Lintel band | 8. Holding down bolt |
| 2. Eaves level (Roof) band | 9. Brick/stone wall |
| 3. Gable band | 10. Door lintel integrated with roof band |
| 4. Door | a) Perspective view |
| 5. Window | b) Details of truss connection with wall |
| 6. Vertical steel bar | c) Detail of integrating door lintel with roof band |
| 7. Rafter | |

FIG. 7 OVERALL ARRANGEMENT OF REINFORCING LOW STRENGTH MASONRY BUILDING HAVING PITCHED ROOF

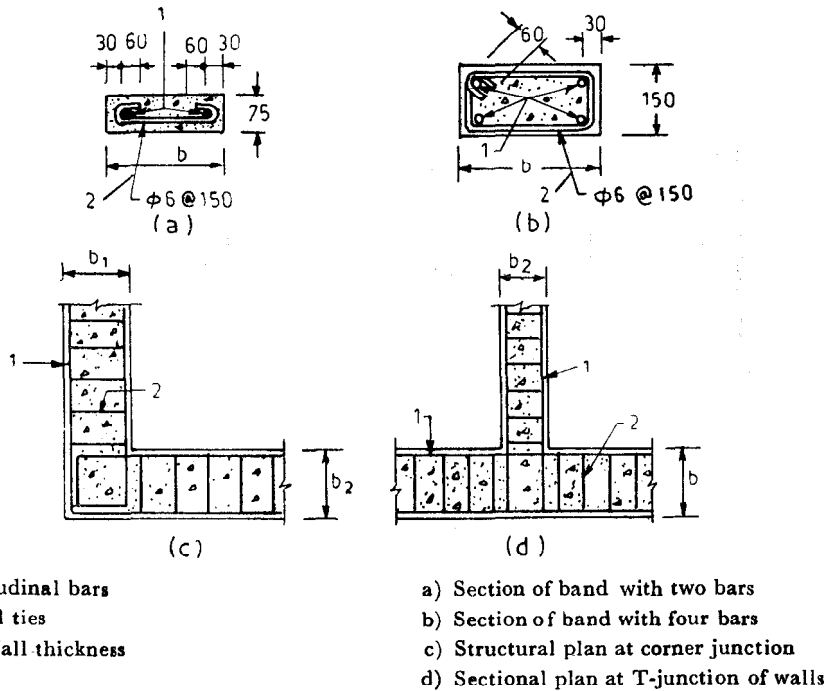

All dimensions in millimetres.

FIG. 8 REINFORCEMENT AND BENDING DETAIL IN REINFORCED CONCRETE BAND

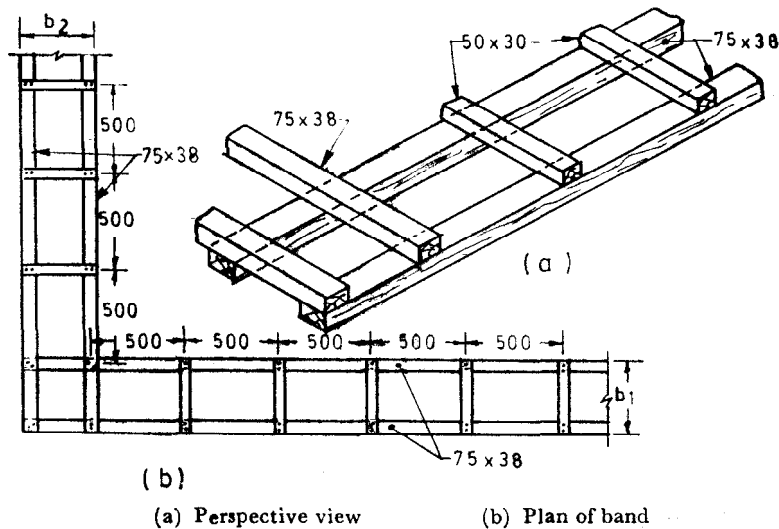

FIG. 9 WOODEN BAND FOR LOW-STRENGTH MASONRY BUILDINGS

8.5.7 Vertical Reinforcement

Vertical steel at corners and junctions of walls which are up to 350 mm thick should be provided as specified in Table 4. For walls thicker than 350 mm, the area of the bars should be proportionately increased.

8.5.7.1 The vertical reinforcement should be properly embedded in the plinth masonry of foundations and roof slab or roof band so as to develop its tensile strength in bond. It should pass through the lintel bands and floor slabs or

floor level bands in all storeys. Bars in different storeys may be welded or suitably lapped.

NOTES

1 Typical details of providing vertical steel in brickwork at corners and T-junctions are shown in Fig. 10.

2 For providing vertical bar in stone masonry, use of a casing pipe is recommended around which masonry be built to height of 600 mm (see Fig. 11). The pipe is kept loose by rotating it during masonry construction. It is then raised and the cavity below is filled with M15 (or 1 : 2 : 4) grade of concrete mix and rodded to compact it.

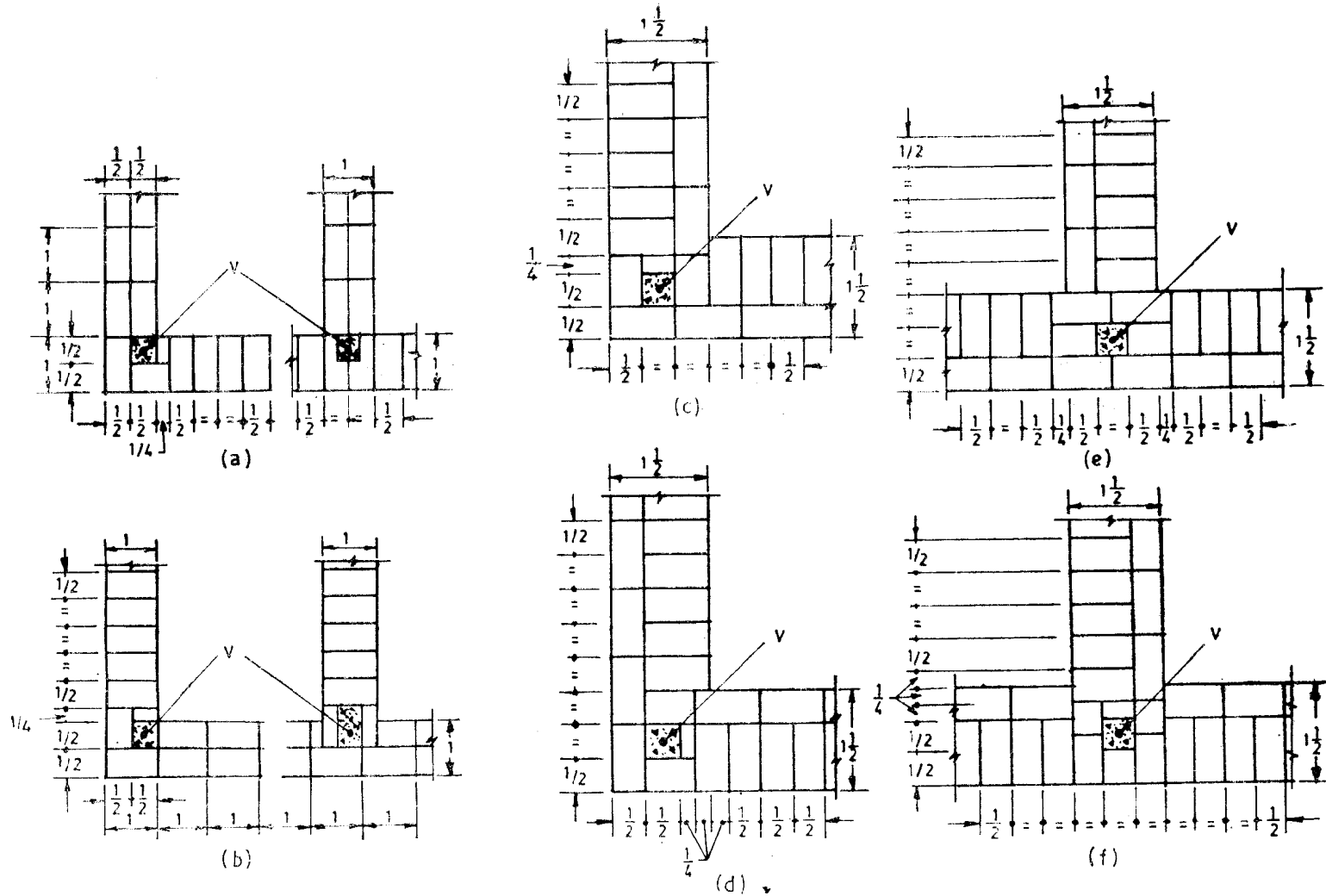

1 — One-brick length; $\frac{1}{2}$ — Half-brick length, V — Vertical steel bar with mortar/concrete filling in pocket.

(a) and (b) — Alternate courses in one-brick wall;

(c) and (d) — Alternate courses at corner junction of $1\frac{1}{2}$ -brick wall;

(e) and (f) — Alternate courses at T-junction of $1\frac{1}{2}$ -brick wall.

FIG. 10 TYPICAL DETAILS OF PROVIDING VERTICAL STEEL BARS IN BRICK MASONRY

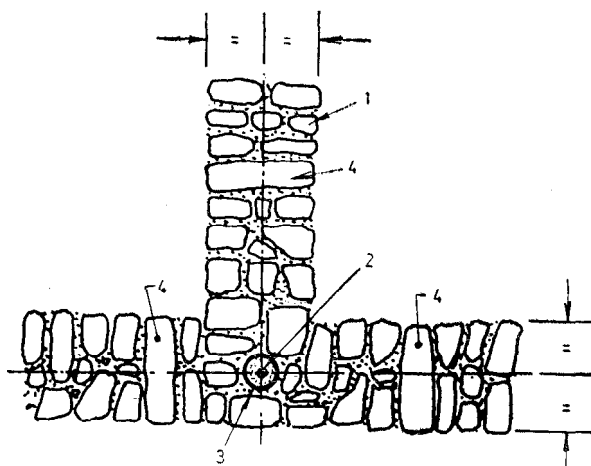

1. Stone wall, 2. Vertical steel bar, 3. Casing pipe, 4. Through stone or bonding element.

FIG. 11 TYPICAL CONSTRUCTION DETAIL FOR INSTALLING VERTICAL STEEL BAR IN RANDOM RUBBLE STONE MASONRY

Table 4 Vertical Steel Reinforcement in Low Strength Masonry Walls

(Clause 8.5.7)

No. of Storeys	Storey	Diameter of HSD Single Bar; in mm, at Each Critical Section for			
		Category A	Category B	Category C	Category D
One	—	Nil	Nil	Nil	10
Two	Top	Nil	Nil	10	10
	Bottom	Nil	Nil	10	12
Three	Top	Nil	10	10	10
	Middle	Nil	10	10	12
	Bottom	Nil	12	12	12

NOTES

1 The diameters given above are for HSD (High Strength Deformed) bars with yield strength 415 MPa. For mild-steel plain bars, use equivalent diameters.

2 The vertical bars should be covered with concrete of M15 grade or with mortar 1 : 3 (cement-sand) in suitably created pockets around the bars (see Fig. 10 & 11). This will ensure their safety from corrosion and good bond with masonry.

3 For category B two storey stone masonry buildings, see note under Table 3.

ANNEX A

(Foreword)

COMMITTEE COMPOSITION

Earthquake Engineering Sectional Committee, CED 39

Chairman

DR A. S. ARYA
72/6 Civil Lines, Roorkee

Members

SHRI O. P. AGGARWAL
SHRI G. SHARAN (*Alternate*)
DR K. G. BHATIA
DR C. KAMESHWARA RAO (*Alternate I*)
SHRI A. K. SINGH (*Alternate II*)
SHRI S. C. BHATIA
DR B. K. RASTOGI (*Alternate*)
DR A. R. CHANDRASEKARAN
DR BRIJESH CHANDRA (*Alternate I*)
DR B. V. K. LAVANIA (*Alternate II*)
DR S. N. CHATTERJEE
SHRI S. K. NAG (*Alternate*)
SHRI K. T. CHAUBAL
DR B. K. PAUL (*Alternate*)
DR A. V. CHUMMAR
DR S. K. KAUSHIK (*Alternate*)
DIRECTOR EMBANKMENT (N & W)
DIRECTOR CMDDD (NW & S) (*Alternate*)
DIRECTOR STANDARDS (B & S), RDSO
JOINT DIRECTOR STANDARDS (B & S) CB-I,
RDSO, LUCKNOW (*Alternate*)
MISS E. DIVATIA
SHRI C. R. VENKATESHA (*Alternate*)
DR S. K. JAIN
DR V. K. GUPTA (*Alternate*)
SHRI I. D. GUPTA
SHRI J. G. PADALE (*Alternate*)
SHRI V. K. KULKARNI
SHRI P. C. KOTESWARA RAO (*Alternate*)
SHRI V. KUMAR
SHRI R. S. BAJAJ (*Alternate*)
SHRI M. Z. KURIEN
SHRI K. V. SUBRAMANIAN (*Alternate*)
SHRI A. K. LAL
SHRI T. R. BHATIA (*Alternate*)
SHRI S. K. MITTAL
SHRI S. S. NARANG
SHRI A. D. NARIAN
SHRI O. P. AGGARWAL (*Alternate*)
SHRI P. L. NARULA
SHRI A. K. SRIVASTAVA (*Alternate*)
RESEARCH OFFICER
DR D. SENGUPTA
SHRI R. K. GROVER (*Alternate*)
DR R. D. SHARMA
SHRI U. S. P. VERMA (*Alternate*)
COL R. K. SINGH
LT COL B. D. BHATTOPADHYAYA
(*Alternate*)
DR P. SRINIVASULU
DR N. LAKSHMANAN (*Alternate*)
SUPERINTENDING ENGINEER (D)
EXECUTIVE ENGINEER (D) II (*Alternate*)
DR A. N. TANDON
SHRI Y. R. TANEJA,
Director (Civ Engg)

Representing

Indian Roads Congress, New Delhi
Bharat Heavy Electricals Ltd, New Delhi
National Geophysical Research Institute (CSIR), Hyderabad
Department of Earthquake Engineering, University of Roorkee,
Roorkee
Indian Meteorological Department, New Delhi
North Eastern Council, Shillong
Indian Society of Earthquake Technology, Roorkee
Central Water Commission (ERDD), New Delhi
Railway Board, Ministry of Railways
National Hydro-Electric Power Corporation Ltd, New Delhi
Indian Institute of Technology, Kanpur
Central Water & Power Research Station, Pune
Department of Atomic Energy, Bombay
National Thermal Power Corporation Ltd, New Delhi
Tata Consulting Engineers, Bombay
National Buildings Organization, New Delhi
Central Building Research Institute, Roorkee
Central Water Commission (CMDD), New Delhi
Ministry of Transport, Department of Surface Transport (Roads
Wing), New Delhi
Geological Survey of India, Calcutta
Irrigation Department, Govt of Maharashtra, Nasik
Engineers India Ltd, New Delhi
Nuclear Power Corporation, Bombay
Engineer-in-Chief's Branch, Army Headquarters, New Delhi
Structural Engineering Research Centre (CSIR), Madras
Central Public Works Department, New Delhi
In personal capacity (B-7/50 Safdarjung Development Area, New Delhi)
Director General, BIS (*Ex-officio Member*)

Member-Secretary

SHRI S. S. SETHI
Director (Civ Engg), BIS

Standard Mark

The use of the Standard Mark is governed by the provisions of the *Bureau of Indian Standards Act, 1986* and the Rules and Regulations made thereunder. The Standard Mark on products covered by an Indian Standard conveys the assurance that they have been produced to comply with the requirements of that standard under a well defined system of inspection, testing and quality control which is devised and supervised by BIS and operated by the producer. Standard marked products are also continuously checked by BIS for conformity to that standard as a further safeguard. Details of conditions under which a licence for the use of the Standard Mark may be granted to manufacturers or producers may be obtained from the Bureau of Indian Standards.

Bureau of Indian Standards

BIS is a statutory institution established under the *Bureau of Indian Standards Act, 1986* to promote harmonious development of the activities of standardization, marking and quality certification of goods and attending to connected matters in the country.

Copyright

BIS has the copyright of all its publications. No part of these publications may be reproduced in any form without the prior permission in writing of BIS. This does not preclude the free use, in the course of implementing the standard, of necessary details, such as symbols and sizes, type or grade designations. Enquiries relating to copyright be addressed to the Director (Publications), BIS.

Review of Indian Standards

Amendments are issued to standards as the need arises on the basis of comments. Standards are also reviewed periodically; a standard along with amendments is reaffirmed when such review indicates that no changes are needed; if the review indicates that changes are needed, it is taken up for revision. Users of Indian Standards should ascertain that they are in possession of the latest amendments or edition by referring to the latest issue of 'BIS Handbook' and 'Standards Monthly Additions'. Comments on this Indian Standard may be sent to BIS giving the following reference:

Doc : No. CED 39 (5269)

Amendments Issued Since Publication

Amend No.	Date of Issue	Text Affected

BUREAU OF INDIAN STANDARDS

Headquarters:

Manak Bhavan, 9 Bahadur Shah Zafar Marg, New Delhi 110002
Telephones : 331 01 31, 331 13 75

Telegrams : Manaksanstha
(Common to all offices)

Regional Offices :

Telephone

Central : Manak Bhavan, 9 Bahadur Shah Zafar Marg
NEW DELHI 110002

{ 331 01 31
331 13 75

Eastern : 1/14 C. I. T. Scheme VII M, V. I. P. Road, Maniktola
CALCUTTA 700054

{ 37 84 99, 37 85 61
37 86 26, 37 86 62

Northern : SCO 445-446, Sector 35-C, CHANDIGARH 160036

{ 53 38 43, 53 16 40
53 23 84

Southern : C. I. T. Campus, IV Cross Road, MADRAS 600113

{ 235 02 16, 235 04 42
235 15 19, 235 23 15

Western : Manakalaya, E9 MIDC, Marol, Andheri (East)
BOMBAY 400093

{ 632 92 95, 632 78 58
632 78 91, 632 78 92

Branches : AHMADABAD. BANGALORE. BHOPAL. BHUBANESHWAR.
COIMBATORE. FARIDABAD. GHAZIABAD. GUWAHATI. HYDERABAD.
JAIPUR. KANPUR. LUCKNOW. PATNA. THIRUVANANTHAPURAM.

AMENDMENT NO. 1 JANUARY 1996
TO
IS 13828 : 1993 IMPROVING EARTHQUAKE
RESISTANCE OF LOW STRENGTH MASONRY
BUILDINGS — GUIDELINES

(*Second cover page, Foreword, para 2, line 10*) — Add 'and 1993' after 'in 1976'.

(*Page 1, clause 1.1.1*) — Substitute the following for the existing clause:

"1.1.1 The provisions of this standard are applicable in all seismic zones. No special provisions are considered necessary for buildings in seismic zones I and II if cement-sand mortar not leaner than 1 : 6 is used in masonry and 'through' stones or bonding elements are used in stone walls."

(*Page 1, clause 2*) — Substitute '1597 (Part 1) : 1992' for '1597 (Part 1) : 1967' and '1904 : 1986' for '1904 : 1984'.

(*Page 3, Table 1, col 2*) — Substitute 'less than 0.05' for the existing matter against category A and 'Equal to or more than 0.12' for the existing matter against category E.

(*Page 3, clause 8.1.6, last line*) — Substitute '1.5' for '1 5'.

(*Page 4, clause 8.3.1*) — Substitute 'IS 1597 (Part 1) : 1992' for 'IS 1597 (Part 1) : 1967'.

(*Page 6, Figure 4*) — Substitute the following for the existing figure:

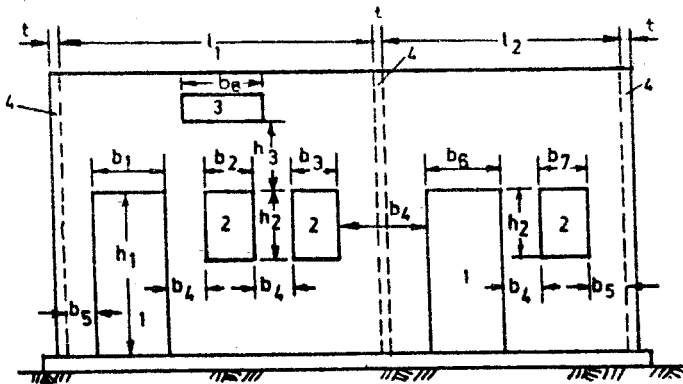

Amend No. 1 to IS 13828 : 1993

(Page 6, Table 2) — Add the following matter after (iv) :

'v) Width of opening of ventilator b_8, Max 750 mm 750 mm'

(Page 6, Figure 5) — Substitute the following for the existing figure:

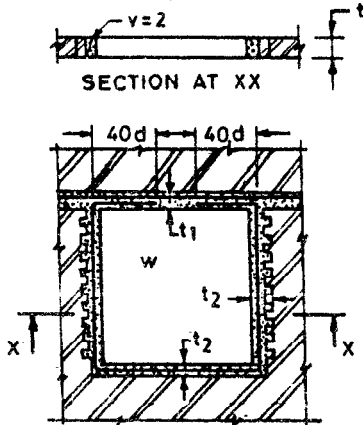

W = Window t_2 = Thickness of concrete in jamb
 t = Wall thickness v = Vertical bar
 t_1 = Lintel thickness d = Diameter of reinforcing bars

FIG. 5 STRENGTHENING MASONRY AROUND OPENING

(Page 6, Table 3) — Against building category A, delete 1 and 2 and c, f in the first line and substitute in col 2 '1, 2 and 3' for '3' in the second line as given below:

(1)	(2)	(3)
A	1, 2 and 3	b, c, f, g

(Page 11) — Insert the composition of the Earthquake Resistant Subcommittee, CED 39:1 as follows:.

'Earthquake Resistant Construction Subcommittee, CED 39 : 1

Convener

Representing

DR A. S. ARYA

In personal capacity (72/6 Civil Lines, Roorkee)

Members

SHRI N. K. BHATTACHARYA
 SHRI B. K. CHAKRABORTY
 SHRI D. P. SINGH (*Alternate*)
 SHRI D. N. GHOSAL
 DR SUDHIR K. JAIN
 DR A. S. R. SAI (*Alternate*)
 SHRI M. P. JAISINGH
 JOINT DIRECTOR STANDARDS
 (B&S) CB-1
 ASSTT DIRECTOR (B & S) CB-1
 (*Alternate*)
 SHRI V. KAPUR
 SHRI V. K. KAPOOR (*Alternate*)
 SHRI M. KUNDU
 SHRI A. K. LAL
 SHRI T. R. BHATIA (*Alternate*)
 DR B. C. MATHUR
 DR (MRS) P. R. BOSE (*Alternate*)
 SHRI G. M. SHOUNTHU
 DR P. SRINIVASULU
 DR N. LAKSHMANAN (*Alternate*)
 SHRI SUBRATA CHAKRAVARTY
 SUPERINTENDING ENGINEER (DESIGN)
 SUPERINTENDING SURVEYOR OF
 WORKS (NDZ)
 SUPERINTENDING ENGINEER (D)
 (*Alternate*)

Representing

Engineer-in-Chief's Branch, New Delhi
 Housing and Urban Development Corporation, New Delhi
 North Eastern Council, Shillong
 Indian Institute of Technology, Kanpur
 Central Buildings Research Institute, Roorkee
 Railway Board, Ministry of Railways
 Public Works Department, Govt of Himachal Pradesh, Shimla
 Hindustan Prefab Limited, New Delhi
 National Buildings Organization, New Delhi
 University of Roorkee, Department of Earthquake
 Engineering, Roorkee
 Public Works Department, Jammu & Kashmir
 Structural Engineering Research Centre (CSIR), Madras
 Public Works Department, Government of Assam, Guwahati
 Public Works Department, Government of Gujrat
 Central Public Works Department, New Delhi

AMENDMENT NO. 2 APRIL 2002
TO
IS 13828 : 1993 IMPROVING EARTHQUAKE
RESISTANCE OF LOW STRENGTH MASONRY
BUILDINGS — GUIDELINES

[*Page 1, clause 1.1.1 (see also Amendment No. 1)*] — Substitute 'zone II' for 'zones I and II'

(*Page 1, clause 3.6*) — Substitute the following for the existing:

'3.6 Seismic Zone and Seismic Coefficient

The seismic zones II to V as classified and the corresponding zone factors as specified in 6.4.2 (Table 2) of IS 1893 (Part 1).'

(*Page 1, clause 3.7*) — Substitute the following for the existing:

'3.7 Zone Factor (Z)

It is a factor to obtain the design spectrum depending on the perceived maximum seismic risk characterized by maximum considered earthquake (MCE) in the zone in which the structure is located.'

(CED 39)