

IS 13827 : 1993

भारतीय मानक

मिट्टी के भवनों की भूकम्प प्रतिरोधिता में सुधार —  
मार्गदर्शी सिद्धान्त

*Indian Standard*

IMPROVING EARTHQUAKE RESISTANCE OF  
EARTHEN BUILDINGS — GUIDELINES

UDC 699.841 ( 026 ) : 728.61

© BIS 1993

BUREAU OF INDIAN STANDARDS  
MANAK BHAVAN, 9 BAHADUR SHAH ZAFAR MARG  
NEW DELHI 110002

October 1993

Price Group 7

## FOREWORD

This Indian Standard was adopted by the Bureau of Indian Standards, after the draft finalized by the Earthquake Engineering Sectional Committee had been approved by the Civil Engineering Division Council.

Himalayan Naga Lushai region, Indo-Gangetic Plain, Western India and Kutch and Kathiawar regions are geologically unstable parts of the country and some devastating earthquakes of the world have occurred there. A major part of the peninsular India has also been visited by moderate earthquakes, but these were relatively few in number and had considerably lesser intensity. It has been a long felt need to rationalize the earthquake resistant design and construction of structures taking into account seismic data from studies of these Indian earthquakes, particularly in view of the heavy construction programme at present all over the country. It is to serve this purpose that IS 1893 : 1984 'Criteria for earthquake resistant design of structures' was prepared. It lays down the seismic zones, the basic seismic coefficients and other factors and criteria for various structures. Subsequently IS 4326 on earthquake resistant construction of buildings in seismic zones covering the selection of materials, and type of construction was prepared in 1967 and revised in 1976 and 1993. But nothing had so far been done to cover earthen buildings. Realising that about 50 percent of all housing in India consists of earthen walls and seeking their poor performance in Himachal and North Bihar earthquakes, it was decided to prepare guidelines for improving earthquake resistance construction of such buildings.

In preparing this standard, considerable assistance has been derived from the 'Guidelines for Earthquake Resistant Non-Engineered Construction', as published by the International Association for Earthquake Engineering, in October 1986 reflecting present international experience and opinion on the subject. This standard should be read in conjunction with IS 1893 : 1984.

The Sectional Committee responsible for the preparation of this standard has taken into consideration the views of all who are interested in this field and has related the standard to the prevailing practices in the country. Due weightage has also been given to the need for international co-ordination among the standards and practices prevailing in different countries of the world.

The Committee responsible for the preparation of this standard is given at Annex B.

## *Indian Standard*

# IMPROVING EARTHQUAKE RESISTANCE OF EARTHEN BUILDINGS — GUIDELINES

### 1 SCOPE

**1.1** The guidelines covered in this standard deal with the design and construction aspects for improving earthquake resistance of earthen houses, without the use of stabilizers, such as cement, lime, asphalt, admixtures, etc.

**1.2** The provisions of this standard are applicable for seismic zones III, IV and V. No special provisions are considered necessary in zones I and II ( see IS 1893 : 1984 for seismic zones ).

#### NOTES

1 Earthen buildings are inherently weak against water and earthquakes, and should preferably be avoided in flood prone, high rainfall areas and seismic zones IV and V.

2 Attention is hereby drawn to the fact that earthen construction as dealt with herein will neither qualify as engineered construction nor totally free from collapse in severe seismic intensities VIII and IX on MMI<sup>1</sup> scale. However, inclusion of special design and construction features as recommended in this standard will raise their weather and seismic resistance appreciably reducing greatly the chances of collapse even in such seismic intensities.

### 2 REFERENCES

The following Indian Standards are the necessary adjuncts to this standard:

<i>IS No.</i>	<i>Title</i>
883 : 1993	Code of practice for design of structural timber in building ( <i>fourth revision</i> )
1893 : 1984	Criteria for earthquake resistant design of structures
2720 ( Part 7 ) : 1980	Methods of test for soils : Part 7 Determination of water content — dry density relation using light compaction ( <i>second revision</i> )

### 3 TERMINOLOGY

**3.0** For the purposes of this standard, the following definitions shall apply.

**3.1** Earthen houses will include those constructed using clay mud lumps, unburnt clay brick or block ( adobe ), compacted soil in wood forms, etc, without using stabilizers.

#### 3.2 Adobe

Sun dried clay blocks or clay bricks.

#### 3.3 Box System

A bearing wall structure without a space frame, the horizontal forces being resisted by the walls acting as shear walls.

#### 3.4 Band

A reinforced concrete or reinforced brick or wooden runner provided horizontally in the walls to tie them together and to impart horizontal bending strength in them.

#### 3.5 Seismic Zone and Seismic Coefficient

The seismic zones I to V as classified and the corresponding basic seismic coefficient  $\alpha_0$  as specified in 3.4 of IS 1893 : 1984.

#### 3.6 Design Seismic Coefficient, $\sigma_h$

The value of horizontal seismic coefficient computed taking into account the soil foundation system and the importance factor as specified in 3.4.2.3 (a) of IS 1893 : 1984.

### 4 GENERAL CONSIDERATIONS

**4.1** For the safety of earthen houses, appropriate precautions must be taken against the actions of rain and flood waters and earthquakes. Minimum precautions are recommended in this standard.

**4.2** Whereas dry clay block is hard and strong in compression and shear, water penetration will make it soft and weak, the reduction in strength could be as high as 80 to 90 percent. Hence, once built, ingress of moisture in the walls must be prevented by the protection, roof projection and waterproof mud plastering.

**4.3** These recommendations are low-cost and do not include the use of stabilizers, which are rather costly though effective in increasing the strength and water-resistance of the clay units or walls. Where feasible time-stabilized compacted clay blocks or cement-stabilized sandy soil blocks may be used with compatible stronger mortars.

#### 4.4 Lightness

Since the earthquake force is a function of mass, the building shall be as light as possible, consistent with structural safety and functional requirements. Roofs of buildings should, in particular, be made of light weight type.

#### 4.5 Height

Experience in intensity areas of VIII has shown the high vulnerability of two-storeyed houses,

<sup>1</sup>Modified Mercalli Intensity.

hence only one storey construction should preferably be adopted in seismic zones IV and V.

#### 4.6 Shape of Building

For better earthquake resistance, the building should have a simple rectangular plan and be symmetrical, as far as possible about both the axes. The load bearing walls should run continuously in both directions. Large houses may have an inner courtyard for light and ventilation with proper drainage outlets, instead of having projections giving rise to L, T shape plans.

### 5 CONSTRUCTION OF EARTHEN WALLS

5.0 Earthen walls may be constructed in the following four ways.

5.1 Hand-formed in layers using mud-lumps to form walls.

5.2 Built by using sun-dried blocks or adobe which may be cut from hardened soil, or formed in moulds, or moulded and compacted and laid in courses using clay mud as mortar.

5.3 Built by using rammed earth (Pise or Tapial) in which moist soil is filled between wall forms and compacted manually or mechanically.

5.4 Constructed using wood, bamboo or cane structure with wood, bamboo, cane or ikra mesh enclosures plastered with mud (Assam type construction).

5.5 Whereas systems 5.1, 5.2 and 5.3 depend on the strength of earthen walls for stability, the system 5.4 behaves like wood frame and its construction has been dealt with under 12.

### 6 SUITABILITY OF SOIL

6.0 The following qualitative tests may be used for determining the suitability of a soil for earthen construction.

#### 6.1 Dry Strength Test

Five or six small balls of soil of approximately 2 cm in diameter are made. Once they are dry

(after 48 hours), each ball is crushed between the forefinger and the thumb. If they are strong enough that none of them breaks, the soil has enough clay to be used in the adobe construction, provided that some control over the mortar micro-fissures caused by the drying process is exercised (see Fig. 1).

NOTE — If some of the balls break, the soil is not considered to be adequate, because it does not have enough clay and should be discarded.

#### 6.2 Fissure Control Test

At least eight folded units are made with mortars made with mixtures in different proportions of soil and coarse sand. It is recommended that the proportion of soil to coarse sand vary between 1 : 0 and 1 : 3 in volume. The unit having the least content of coarse sand which, when opened after 48 hours, does not show visible fissures in the mortar, will indicate the most adequate proportion of soil/sand for adobe constructions, giving the highest strength.

#### 6.3 Strength Test of Adobe

The strength of adobe may be qualitatively ascertained as follows:

After 4 weeks of sun drying the adobe, it should be strong enough to support in bending the weight of a person 60-70 kg (see Fig. 2). If it breaks, more clay and fibrous material is required to be added.

6.4 Quantitatively, the compressive strength may be determined by testing 100 mm cubes of clay after completely drying them. A minimum value of 1.2 N/mm<sup>2</sup> will be desirable.

### 7 HAND-FORMED LAYERED CONSTRUCTION

7.1 Walls built by hand-forming are the most primitive and weakest of all earthen walls, since enough moisture for full dispersion of clay is not usually employed, yet fissures also develop horizontally and vertically. Use of straw is recommended in the clay, so as to impart strength and reduction of fissures.

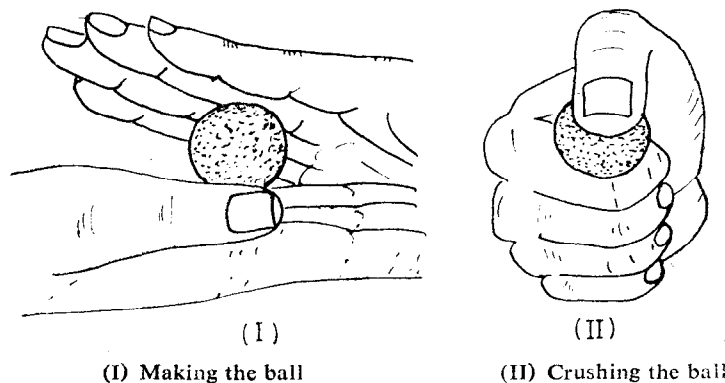
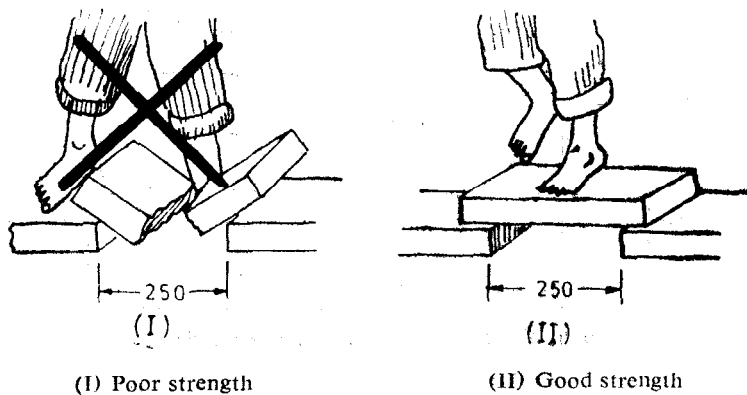

FIG. 1 DRY BALL STRENGTH TEST FOR SOIL



All dimensions in millimetres.

FIG. 2 FIELD TESTING OF ADOBE STRENGTH

**7.2** The quality of construction will improve if the clay-water-straw mixture was allowed to rest for 7 days (minimum 3 days) before use in walls so that thorough dispersion of moisture in clay and decomposition of straw into fibres takes place.

**7.3** The area of the lower layer should be moistened well before adding the new layer so as to minimize the horizontal fissures at the joints.

## 8 BLOCK OR ADOBE CONSTRUCTION

**8.1** Suitable soil should be used for making the blocks, by using uniform size of moulds, after keeping the soil-water mix for 24 hours. The blocks should be allowed to dry out of the moulds so as to allow 'free' shrinkage without developing fissures.

**8.2** Block sizes are not standardized yet and various sizes are used in the country and the world. The following sizes of blocks are recommended for making 380 mm thick walls:

Rectangular : 380 mm × 250 mm × 110 mm  
(Overlap of about 125 mm)

Square : 380 mm × 380 mm × 110 mm  
(Overlap of about 190 mm)

**8.2.1** The square type will be better for stronger construction in view of less vertical joints between units and better breaking of vertical joints.

**8.3** The mud 'mortar' used to join the blocks together should be the same soil as used in making blocks. However, to make it non-shrinking, straw in the ratio 1 : 1, by volume, should be mixed. The wet mix should be allowed to rest for 7 days (minimum 3 days) before use. The lower layer of adobes should be moistened before the 'mortar' is laid. Also, the surface of the adobes to be laid should be moistened for a

few minutes before the adobe is laid. If the mortar is seen to fissure on drying, some sand could be added to the mixture, as indicated by the 'fissure control test' in 6.2.

**8.4** The usual good principles of bonds in masonry should be adopted for construction of adobe walls, that is:

- all courses should be laid level,
- the vertical joints should be broken between the consecutive courses by overlap of adobes and should be fully filled with mortar (see Fig. 3), and
- the perpendicular joints between walls should be made in such a way that through vertical joint is avoided (see Fig. 3).

## 9 RAMMED EARTH CONSTRUCTION

**9.0** Rammed earth construction is also known as 'Pise' or 'Tapial' construction in some countries.

**9.1** To construct walls, in this method, most soil is poured in long wooden forms of the walls and compacted to achieve the desired density. The soil suitable for rammed earth construction will generally have less clay than that used for making adobes. The moisture content should be kept less but close to optimum moisture content determined by Proctor Compaction Test [see IS 2740 (Part 7) : 1980].

**9.2** To control shrinkage fissures on drying, prior testing may be required for determining the quantity of sand to be added to the clayey soil, based on the moisture, the layering and the amount of compaction to be used in the construction.

**9.3** The soil should be placed in layers of about 100 mm thickness and fully compacted, then water should be sprinkled on the compacted layer before placing the next layer of 100 mm. The total height of this block achieved this way

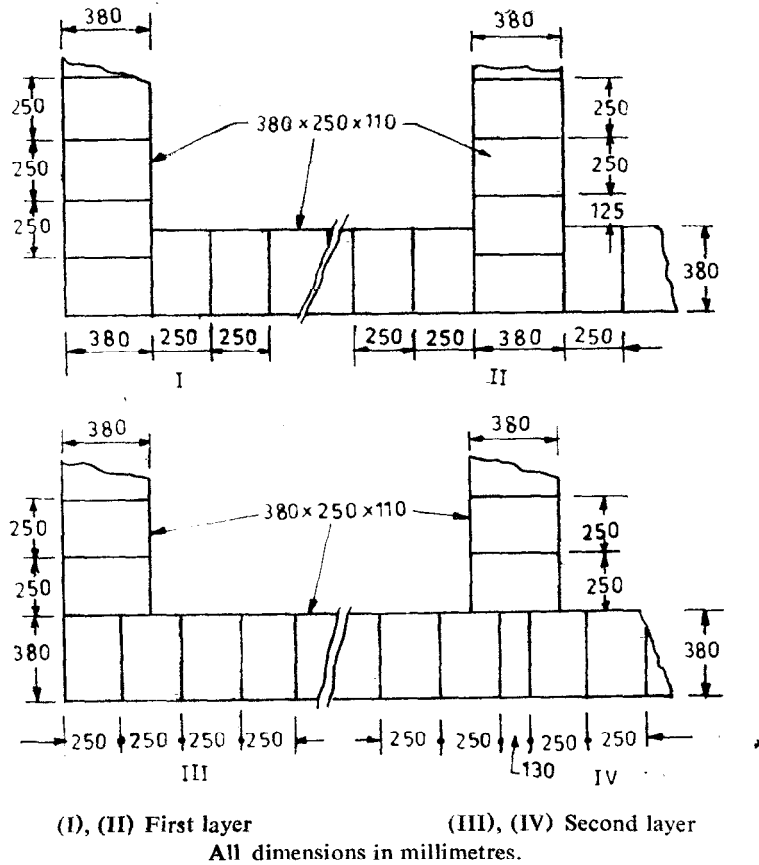

FIG. 3 TYPICAL BOND DETAILS IN ADOBE WALL

may be kept 500 to 800 mm. Before starting the new block, sufficient water should be poured on the completed layer to ensure its connection with the new layer.

9.4 Higher compaction leads to higher strength but up to a limit only. Compaction should be standardized. The following procedure is recommended:

‘50 strokes per 1 000 cm<sup>2</sup> of wall area using a wooden mallet of about 8 to 10 kg weight.’

9.5 Small amount of straw, in the ratio of not more than one-fourth of the volume of soil-water mixture, may be used in the soil for fissure control.

## 10 RECOMMENDATIONS FOR SEISMIC AREAS

### 10.1 Walls

10.1.1 The height of the adobe building should be restricted to one storey plus attic only in seismic zones V and IV and to two storeys in zone III. Important building ( $I \geq 1.5$ ) should not be constructed with earthen walls in seismic zones IV and V and restricted to only one storey in seismic zone III.

10.1.2 The length of a wall, between two consecutive walls at right angles to it, should not be greater than 10 times the wall thickness  $t$  nor greater than  $64 t^2/h$  where  $h$  is the height of wall ( see Fig. 4 ).

10.1.3 When a longer wall is required, the walls should be strengthened by intermediate vertical buttresses ( see Fig. 4 ).

10.1.4 The height of wall should not be greater than 8 times its thickness ( see Fig. 4 ).

10.1.5 The width of an opening should not be greater than 1.20 m ( see Fig. 5 ).

10.1.6 The distance between an outside corner and the opening should be not less than 1.20 m.

10.1.7 The sum of the widths of openings in a wall should not exceed  $33\frac{1}{2}$  percent the total wall length in seismic zone V and 40 percent in zones IV and III.

10.1.8 The bearing length ( embedment ) of lintels on each side of an opening should not be less than 300 mm. For an adequate configuration for an earthen house, see 10.5.

10.1.9 Hand-formed walls could preferably be made tapering upwards keeping the minimum thickness 300 mm at top and increasing it with a batter of 1 : 12 at bottom ( see Fig. 4b ).

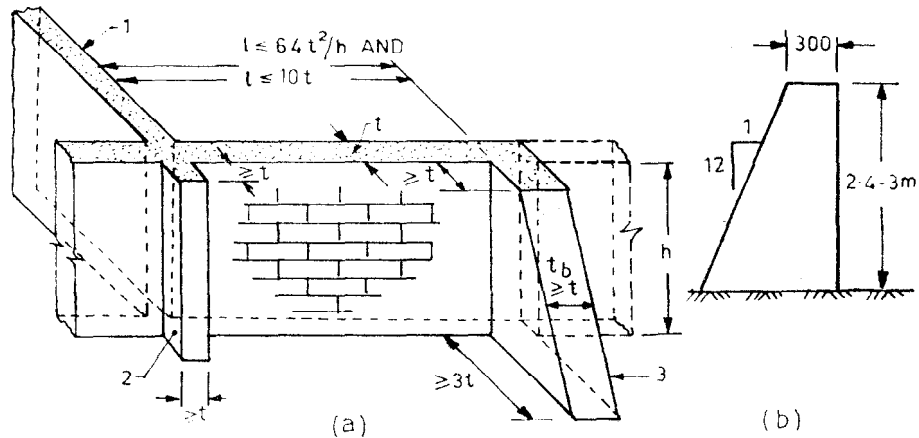

1 — Cross wall, 2 — Pillaster, 3 — Buttress,  $t$  — Wall thickness  
 (a) Walls and buttressing (b) Tapered wall

All dimensions in millimetres.  
**FIG. 4 WALL DIMENSIONS**

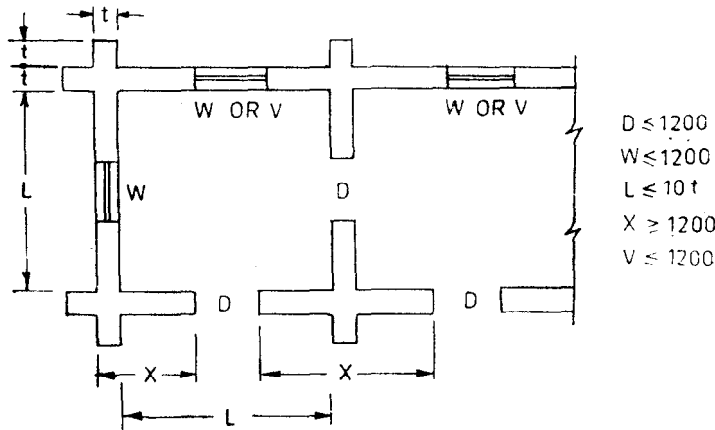

D — Door, W — Window, V — Ventilators

All dimensions in millimetres.

**FIG. 5 WALL DIMENSIONS, PILLASTERS AT CORNERS**

**10.1.10** Providing outside pillasters at all corners and junctions of walls are recommended as these increase the seismic stability of the buildings a great deal ( see Fig. 5 ).

**10.1.11** Special seismic strengthening features may be done as specified in 11.

**10.2 House Site**

**10.2.1** Sites with sandy loose soils, poorly compacted clays, and fill materials should generally be discarded due to their excessive settlements during seismic vibrations. Also, sites with very high water table should be avoided. These recommendations are particularly important for seismic zones V and IV.

**10.2.2** Site shall be above high flood level or the ground shall be raised to this effect.

**10.3 Foundation**

**10.3.1** Width of strip footings of the walls may be kept as follows:

- i) One storey on firm — Equal to wall thickness soil
- ii) 1.5 or 2 storeys on — 1.5 times the wall thickness firm soil
- iii) One storey on soft soil — 1.5 times the wall thickness
- iv) 1.5 or 2 storeys on soft — 2 times the wall thickness soil

**10.3.2** The depth of foundation below existing ground level should at least be 400 mm.

**10.3.3** The footing should preferably be built by using stone, fired brick using cement or lime mortar. Alternatively, it may be made in lean cement concrete with plums (cement : sand : gravel : stones as 1 : 4 : 6 : 10) or without plums as 1 : 5 : 10. Lime could be used in place of cement in the ratio lime : sand : gravel as 1 : 4 : 8.

#### 10.3.4 Plinth Masonry

The wall above foundation up to plinth level should preferably be constructed using stone or burnt bricks laid in cement or lime mortar. Clay mud mortar may be used only as a last resort.

The height of plinth should be above the flood water line or a minimum of 300 mm above ground level. It will be preferable to use a waterproofing layer in the form of waterproof mud (see 13.3) or heavy black polythene or polyethylene sheet at the plinth level before starting the construction of superstructure wall. If adobe itself is used for plinth construction, the outside face of plinth should be protected against damage by water by suitable facia or plaster. A water drain should be made slightly away from the wall to save it from seepage.

#### 10.4 Roof

**10.4.1** The roofing structure must be light, well connected and adequately tied to the walls. Trusses are superior to sloping roofs consisting of only rafters or A frames.

**10.4.2** The roof covering should preferably be of light material, like sheeting of any type. Heavy roofs consisting of wood joists and earth topping are dangerous and should not be used in Zones V and IV. Tiled and slate roofs are also heavier and shall be avoided in zones V and IV.

**10.4.3** If thatch is used for roof covering, it should better be made waterproof and fire-resistant by applying waterproof mud plaster (see 13.3).

**10.4.4** The roof beams, rafters or trusses should preferably be rested on longitudinal wooden elements for distributing the load on walls.

**10.4.5** The slopes and the overhanging will depend on local climatic conditions. In zones subjected to rain and snow, walls protection must be ensured by projecting the roof by about 500 mm beyond the walls (see Fig. 6).

**10.4.6** The roof beams or rafters should be located to avoid their position above door or window lintels. Otherwise, the lintel should be reinforced by an additional lumber (see Fig. 7).

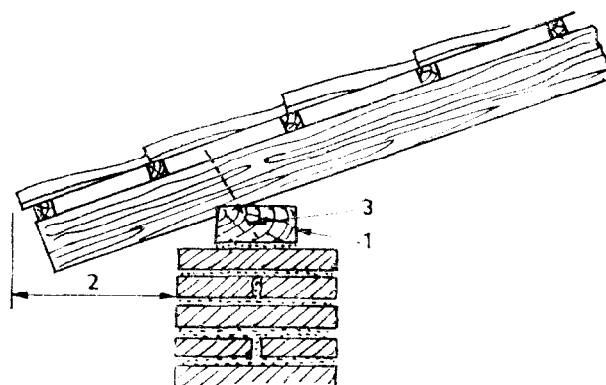

1 — Wooden wall plate 2 — Overhang about 500 mm  
3 — Long spikes or nails

FIG. 6 FIXING WOOD RAFTER TO WALL PLATE

#### 10.5 Adequate Configuration

Summarizing most of the recommendations contained in this standard, a configuration is shown in Fig. 8 which will, in general, be adequate for seismic areas including zone V and IV. Additional seismic strengthening features are presented in 12.

### 11 SEISMIC STRENGTHENING OF BEARING WALL BUILDINGS

#### 11.1 Collar Beam or Horizontal Band

Two horizontal continuous reinforcing and binding beams or bands should be placed, one coinciding with lintels of door and window opening, and the other just below the roof in all walls in seismic zones III, IV and V. Proper connection of ties placed at right angles at the corners and junctions of walls should be ensured. Where the height of wall is not more than 2.5 m, the lintel band can be avoided, but the lintels should be connected to the roof band (see 11.2). The bands could be in the following forms:

- Unfinished rough cut or sawn ( $70 \times 150$  mm in section) lumber in single pieces provided diagonal members for bracing at corners (see Fig. 9a).
- Unfinished rough cut or sawn ( $50 \times 100$  mm or  $70 \times 70$  mm in section) lumber two pieces in parallel with halved joints at corners and junctions of walls placed in parallel (see Fig. 9b).

In each case, the lengthening joint in the elements shall be made using iron-straps with sufficient nails/screws to ensure the strength of the original lumber at the joint.



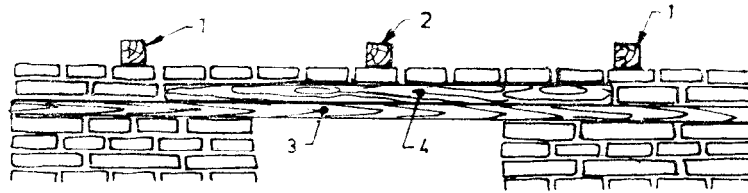

1 — Good position of beam 2 — Avoid this position 3 — Lintel band of wood 4 — Additional lintel

FIG. 7 REINFORCING LINTEL UNDER FLOOR BEAM

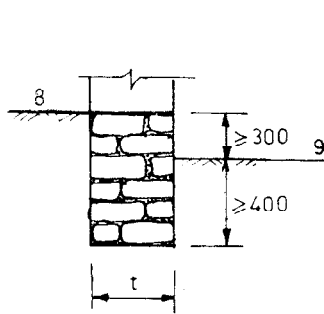
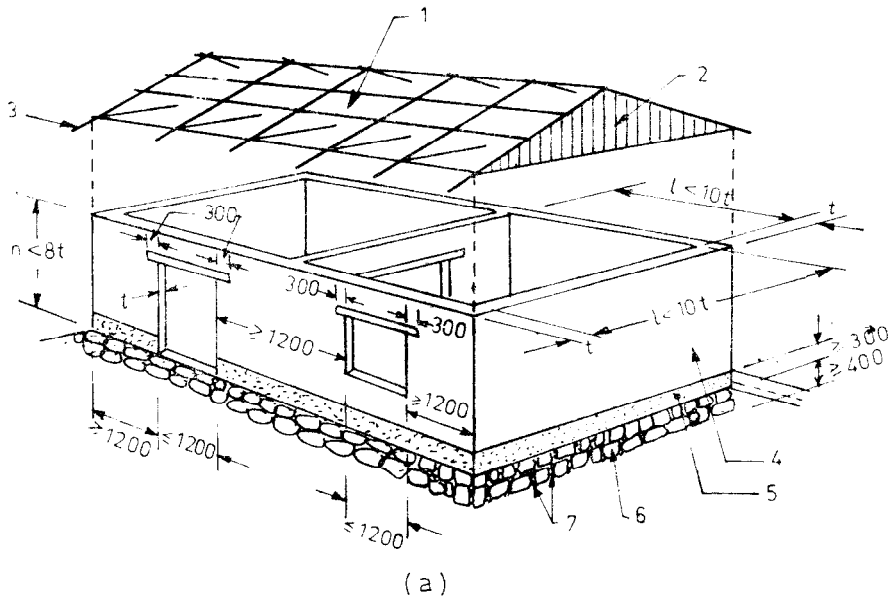

(b)

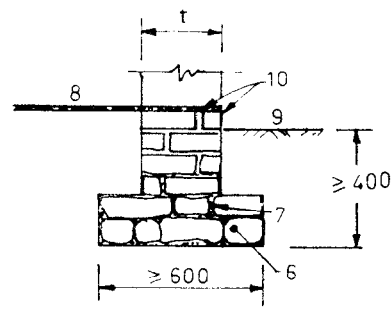

(c)

1 — Light roof 2 — Light gable wall ( matting or boarding ) 3 — Rain protection overhang ( about 500 mm )  
 4 — Stable plaster 5 — Plinth height for flood protection 6 — Stable foundation 7 — Good mortar  
 8 — Floor level 9 — Ground level 10 — Waterproof layer

(a) Building configuration, (b) Footing on firm soil, (c) Footing on soft soil

All dimensions in millimetres.

FIG. 8 ADEQUATE CONFIGURATION OF EARTHEN BUILDING

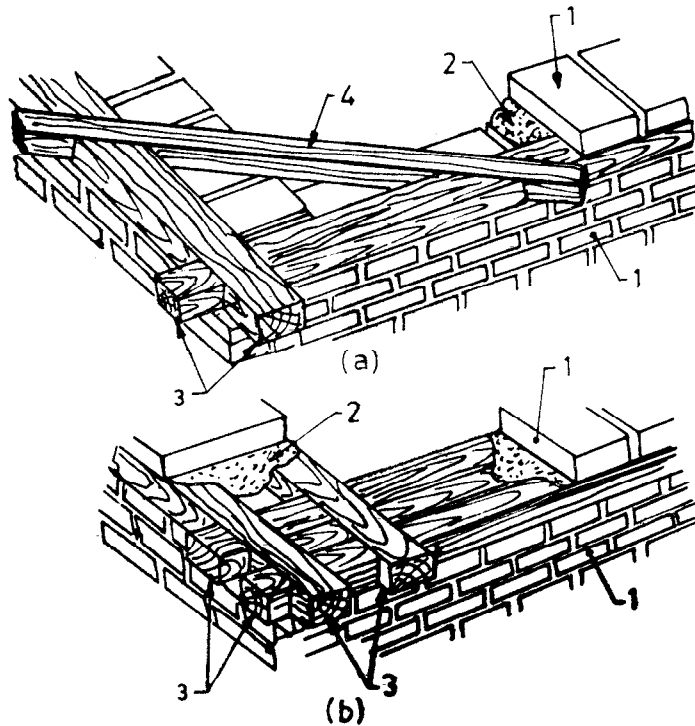

1 — Adobe 2 — Mud mortar 3 — Wooden band 4 — Diagonal brace

(a) Band with single timber and diagonal brace at corner (b) Band with two timbers in parallel

FIG. 9 WOODEN BAND IN WALLS AT LINTEL AND ROOF LEVELS

**11.2 Pillasters and Buttresses**

Where pillasters or buttresses are used, as recommended earlier at corner or T-junctions, the collar beam should cover the buttresses as well, as shown in Fig. 10. Use of diagonal struts at corners will further stiffen the collar beam.

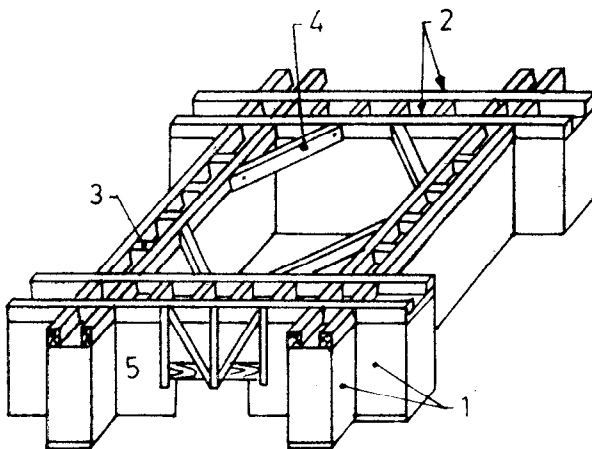

1 — Pillasters at wall junctions 2 — Two parallel timbers  
3 — Wood blocking at about 500 mm 4 — Diagonal brace 5 — Integrating roof band with door/window lintel

FIG. 10 ROOF BAND ON PILLASTERED WALLS

**11.3 Vertical Reinforcement in Walls**

In seismic zone V, mesh form of reinforcing is recommended. Here the whole walls are reinforced by a mesh of canes or bamboos as shown in Fig. 11 along with the collar beams which may in this case be made from canes or bamboos themselves. The vertical canes must be tied to the horizontal canes as well as the collar beam at lintel and the roof beam at eave level (see 11.1).

**12 EARTHEN CONSTRUCTIONS WITH WOOD OR CANE STRUCTURES**

**12.1** The scheme of earthen construction using structural framework of wood or cane, as shown in Fig. 12, consists of vertical posts and horizontal blocking members of wood or large diameter canes or bamboo, the panels being filled with cane, bamboo or some kind of reed matting plastered over both sides with mud. The construction could be done *in situ*, building element-by-element or by using prefabricated panels.

**12.2** For the satisfactory behaviour of this type of construction the following fundamental rules, given in 12.2.1 to 12.2.6, should be observed.

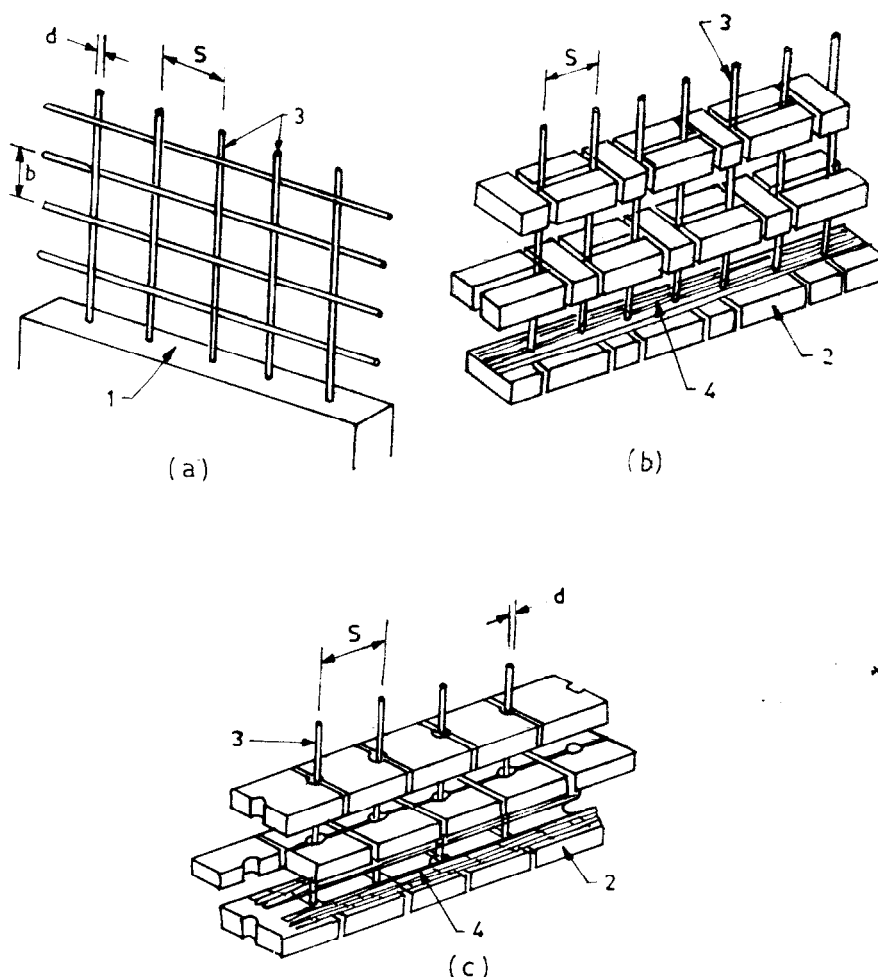

1 — Clay mud wall 2 — Adobe 3 — Vertical cane/bamboo 4 — Horizontal crushed canes/split bamboo  
 every 4th layer of adobe  $b$ ,  $S$  = Spacing about 400 mm  $d$  = Diameter of cane/bamboo about 20 mm  
 (a) Pattern of canes in clay mud walls (b), (c) Pattern in adobe walls

FIG. 11 REINFORCEMENT IN EARTHEN WALLS

**12.2.1** Good connections between the wood or cane elements, so as to ensure an integral behaviour of the structure. The connections are normally fixed with nails. Their number and dimensions should be enough but not excessive so as to split the elements. The connections can also be tied with wires, ropes, leatherstraps, etc.

**12.2.2** Preservation of the wood or cane elements by charring the surface or painting with coal tar, especially in the part embedded in the foundation, which should preferably be of concrete, stone or bricks laid with cement, lime or gypsum mortar.

**12.2.3** In houses, built as a continuous system as in those made with pre-fabricated panels, an upper ring beam should be placed to ensure the integral behaviour of all walls, and to distribute evenly the roofing load ( see 11.1 ).

**12.2.4** The panel filling material should consist of wood or cane mesh, over which a layer of mud and straw ( 1 : 1 in volume ) is placed on each face in the form of plaster. Very often, the meshes are knit in themselves and around the structure.

**12.2.5** The mud filling should be placed only after fixing this upper ring beam and the roof ( after completing the nailing ). This will avoid fissuring caused by the strokes of the nailing operation.

**12.2.6** In the case of pre-fabricated panels, the frames could have economical sections  $25 \times 50$  mm or  $25 \times 75$  mm or larger. The connection between panels is made through nails, but the wood or cane knit mesh over which the mud filling is placed may be fixed without the use of nails.

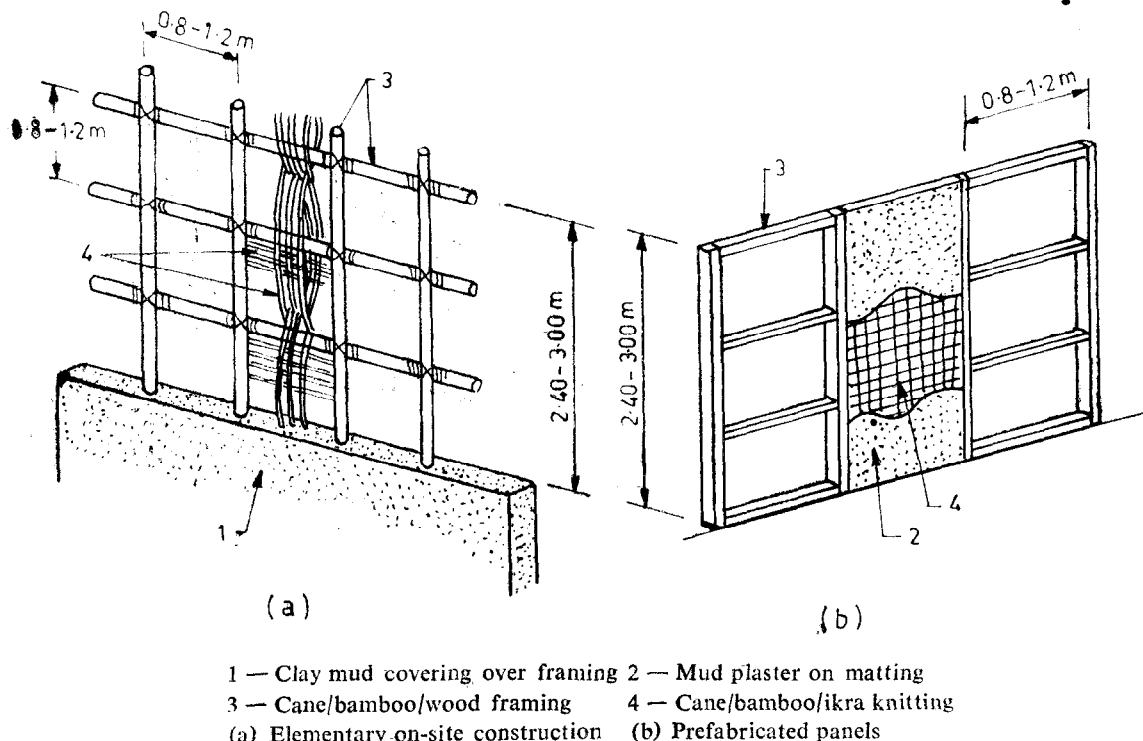
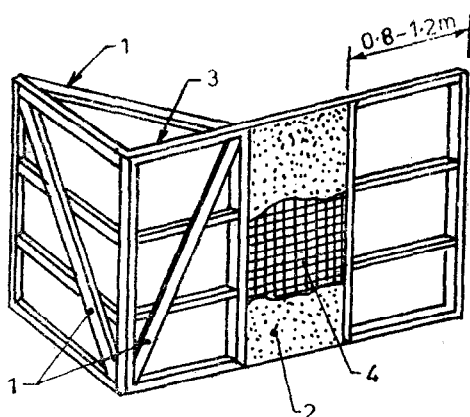

FIG. 12 EARTHEN CONSTRUCTION WITH CANES, BAMBOO OR WOODEN STRUCTURE

### 12.3 Bracing and Braced Frames

For achieving adequate seismic resistance in Zones V and IV, it will be desirable to provide diagonal bracing members in the planes of walls as well as horizontally at the top level of walls. This can be done by using canes or bamboos nailed to the framing members at the ends and intermediate points of intersection, before fixing the panel meshes and applying plaster to them ( see Fig. 13 ).



- 1 — Diagonal brace
- 2 — Mud plaster on matting
- 3 — Cane/bamboo/wood framing
- 4 — Cane/bamboo/ikra knitting

FIG. 13 DIAGONAL BRACING

Schemes for providing internal bracing systems in earthen houses, holdfast to the walls and other alternatives are explained in Annex A.

## 13 PLASTERING AND PAINTING

**13.0** The purpose of plastering and painting is to give protection and durability to the walls and thatch roof, in addition to obvious aesthetic reasons.

**13.1** In dry areas, plastering based on natural additives could be formed in two layers. The first one of about 12 to 15 mm, is a mixture of mud and straw ( 1 : 1 in volume ), plus a natural additive like cowdung used to increase the moisture resistance of the mud, thus preventing the occurrence of fissures during the drying process. The second and last layer is made with fine mud which when dried, should be rubbed with small, hard, rounded pebbles.

**13.2** In wet areas, the walls should be covered with waterproof mud plaster. To obtain this, the following procedure may be followed:

‘Cut-back should be prepared by mixing bitumen 80/100 grade and kerosene oil in the ratio 5 : 1. For 1.8 kg cut-back, 1.5 kg bitumen is melted and is poured in a container having 300 millilitres kerosene oil, with constant stirring, till complete mixing. This mixture can now be mixed with 30 litres of mud mortar to make it both, water repellent and fire resistant.’

**13.3** For improving water and fire resistance of thatch roof, the water proof plaster may be applied on top surfaces of the thatch, 20 to 25 mm thick, and allowed to dry. It may then be coated twice with a wet mixture of cowdung and waterproof plaster in the ratio of 1 : 1, and

allowed to dry again.

**13.4** The exterior of walls after plastering and thatch roof after treatment as explained in **13.3** may be suitably painted using a water-insoluble paint or washed with water solutions of lime or cement or gypsum.

## ANNEX A

( Clause 12.3 )

### INTERNAL BRACING IN EARTHEN HOUSES

#### A-1 INTERNAL BRACING SYSTEM

**A-1.1** Earthen houses are intrinsically very weak under lateral load, hence require very special techniques to make them collapse proof in seismic intensities VIII and IX areas such as vertical tension members as well as diagonal braces. A scheme of using internal braced frames in such houses is shown in Fig. 14. Calculations for single storeyed buildings with flat heavy flexible roofs ( for example, wooden beams with clay topping ) show that even the soft timbers ( Group C in IS 883 : 1993 ) when suitably framed using nail joints can serve the purpose of holding the roof in place in the event when the weak walls give way partially. The frames will also restrain the walls from disintegrating completely.

**A-1.2** In using the method described in A-1.1, the following three systems can be adopted:

- a) *System A* — The whole building plan may be framed as one piece and the external walls built keeping the wooden frame as the inner face of external walls and the internal walls built keeping the frame on one of its faces ( preferably on the bed room side ). Such a frame will have the advantage of redundancy, and use of less number of columns. But the frame can be subjected to torsional stresses under the earthquake motions.
- b) *System B* — Each room may be framed individually, thus the external walls will have the frame only on their inner face, the internal walls will have the frames on both faces, preventing the fall of the inner wall either way. This system will have the advantage of permitting any plan shape without the problem of

torsion of the frames and much greater safety of cross walls. It will, however, consume more timber since all frames on the inner walls will be doubled.

- c) *System C* — In the third system, the frames of system B may be joined across walls making it a stronger whole building frame. Such a system will have the advantages of both A and B systems and can be adopted for the more important buildings such as those built for community services.

As a general guidance, system A may be adopted for near symmetrical plans and system B for general unsymmetrical plans.

#### A-2 HOLDFASTS TO THE WALLS

The earthen walls may be kept no more than 400 mm thick. To improve their behaviour, steel holdfasts of Z-shape may be screwed to the wooden posts at least one for each triangle and be built into the cladding earthen wall.

#### A-3 OTHER ALTERNATIVES AND APPLICATIONS

**A-3.1** As an alternative to wooden frames, steel pipe or angle iron frames of equal strength may be used.

**A-3.2** The internal bracing system will also be appropriately suitable for the seismic safety of random rubble or brick work in mud mortar constructions.

**A-3.3** Such frames could also be inserted in existing low strength masonry houses for retrofitting them against collapse in future earthquakes.

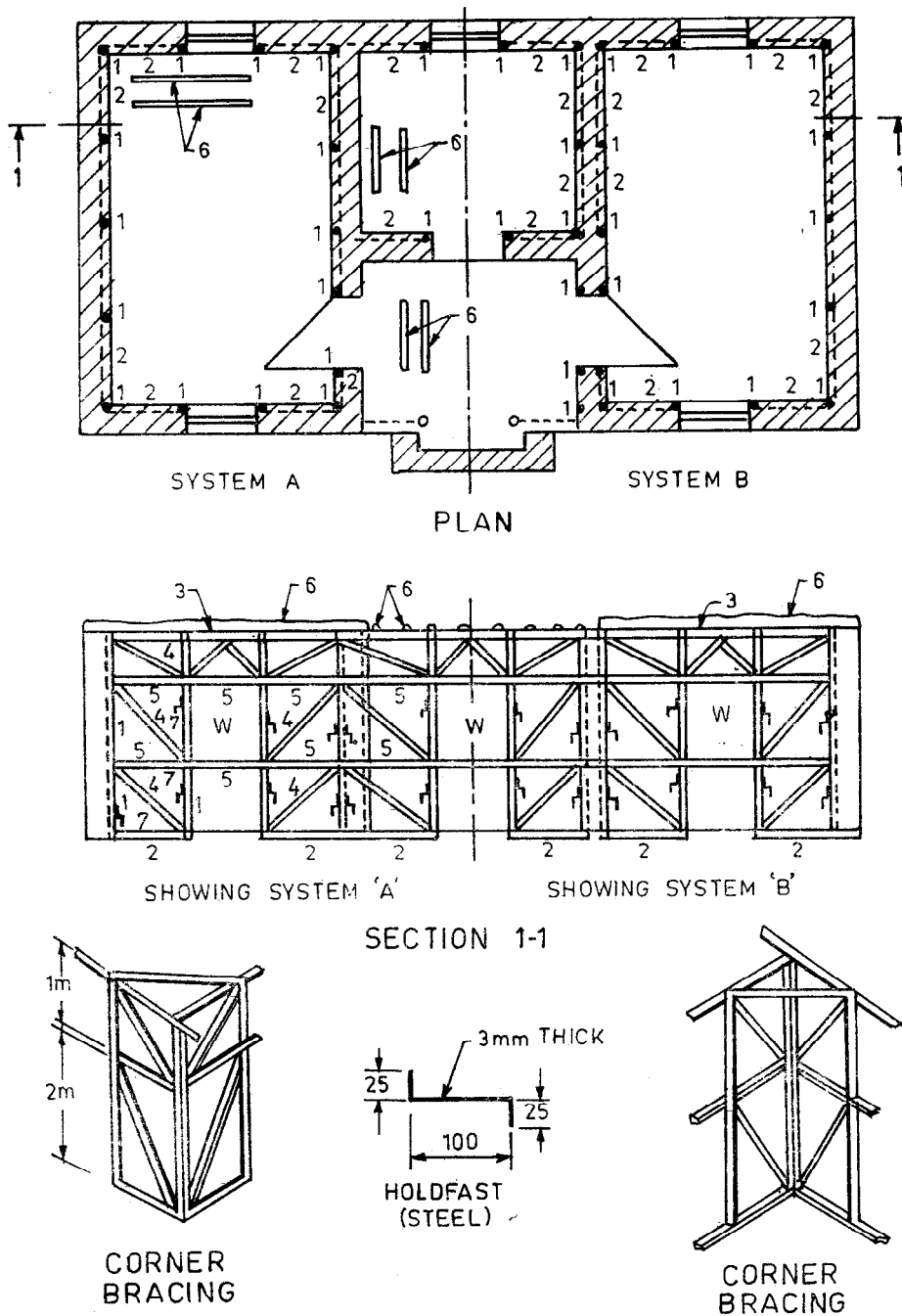

*Minimum Dimensions*

- 1 — Column 100 × 75\* or 100 ϕ 2 — Sill 100 × 75 3 — Beam 100 × 100 or 75 ϕ 4 — Diagonal 100 × 50  
 5 — Strut 100 × 50 6 — Ceiling beam 75 × 125 or 100 ϕ \*Corner 100 × 100 7 — Hold fast

*Joints* — Use 6 gauge nails 75 mm long minimum 2 from each face through iron sheet gussets, minimum 1 mm thickness or straps of 2 mm thickness

All dimensions in millimetres.

FIG. 14 BRACED WOOD FRAME FOR ADOBE AND OTHER WALLS IN MUD MORTAR

## ANNEX B

( Foreword )

## COMMITTEE COMPOSITION

## Earthquake Engineering Sectional Committee, CED 39

## Chairman

DR A. S. ARYA  
72/6 Civil Lines, Roorkee

## Representing

SHRI O. P. AGGARWAL	Indian Roads Congress, New Delhi
SHRI G. SHARAN ( <i>Alternate</i> )	
DR K. G. BHATIA	Bharat Heavy Electricals Ltd, New Delhi
DR C. KAMESHWARA RAO ( <i>Alternate I</i> )	
SHRI A. K. SINGH ( <i>Alternate II</i> )	
SHRI S. C. BHATIA	National Geophysical Research Institute ( CSIR ), Hyderabad
DR B. K. RASTOGI ( <i>Alternate</i> )	
DR A. R. CHANDRASEKARAN	Department of Earthquake Engineering, University of Roorkee, Roorkee
DR BRIJESH CHANDRA ( <i>Alternate I</i> )	
DR B. V. K. LAVANIA ( <i>Alternate II</i> )	
DR S. N. CHATTERJEE	Indian Meteorological Department, New Delhi
SHRI S. K. NAG ( <i>Alternate</i> )	
SHRI K. T. CHAUBAL	North Eastern Council, Shillong
DR B. K. PAUL ( <i>Alternate</i> )	
DR A. V. CHUMMAR	Indian Society of Earthquake Technology, Roorkee
DR S. K. KAUSHIK ( <i>Alternate</i> )	
DIRECTOR EMBANKMENT ( N & W )	Central Water Commission ( ERDD ), New Delhi
DIRECTOR CMDD ( NW & S ) ( <i>Alternate</i> )	
DIRECTOR STANDARDS ( B & S ), RDSO	Railway Board, Ministry of Railways
JOINT DIRECTOR STANDARDS ( B & S ) CB-I, RDSO, LUCKNOW ( <i>Alternate</i> )	
MISS E. DIVATIA	National Hydro-Electric Power Corporation Ltd, New Delhi
SHRI C. R. VENKATESHA ( <i>Alternate</i> )	
SHRI I. D. GUPTA	Central Water & Power Research Station, Pune
SHRI J. G. PADALE ( <i>Alternate</i> )	
SHRI V. K. KULKARNI	Department of Atomic Energy, Bombay
SHRI P. C. KOTESWARA RAO ( <i>Alternate</i> )	
SHRI V. KUMAR	National Thermal Power Corporation Ltd, New Delhi
SHRI R. S. BAJAJ ( <i>Alternate</i> )	
SHRI M. Z. KURIEN	Tata Consulting Engineers, Bombay
SHRI K. V. SUBRAMANIAN ( <i>Alternate</i> )	
SHRI A. K. LAL	National Buildings Organization, New Delhi
SHRI T. R. BHATIA ( <i>Alternate</i> )	
SHRI S. K. MITTAL	Central Building Research Institute, Roorkee
SHRI S. S. NARANG	Central Water Commission ( CMDD ), New Delhi
SHRI A. D. NARIAN	Ministry of Transport, Department of Surface Transport ( Roads Wing ), New Delhi
SHRI O. P. AGGARWAL ( <i>Alternate</i> )	
SHRI P. L. NARULA	Geological Survey of India, Calcutta
SHRI A. K. SRIVASTAVA ( <i>Alternate</i> )	
RESEARCH OFFICER	Irrigation Department, Govt of Maharashtra, Nasik
DR D. SENGUPTA	Engineers India Ltd, New Delhi
SHRI R. K. GROVER ( <i>Alternate</i> )	
DR R. D. SHARMA	Nuclear Power Corporation, Bombay
SHRI U. S. P. VERMA ( <i>Alternate</i> )	
COL R. K. SINGH	Engineer-in-Chief's Branch, Army Headquarters, New Delhi
LT-COL B. D. BHATTOPADHYAYA ( <i>Alternate</i> )	
DR P. SRINIVASULU	Structural Engineering Research Centre ( CSIR ), Madras
DR N. LAKSHMANAN ( <i>Alternate</i> )	
SUPERINTENDING ENGINEER ( D )	Central Public Works Department, New Delhi
EXECUTIVE ENGINEER ( D ) II ( <i>Alternate</i> )	
DR A. N. TANDON	In personal capacity ( B-7/50 Safdarjung Development Area, New Delhi )
SHRI Y. R. TANEJA, Director ( Civ Engg )	Director General, BIS ( <i>Ex-officio Member</i> )

## Member Secretary

SHRI S. S. SETHI  
Director ( Civ Engg ), BIS

( Continued on page 14 )

( Continued from page 13 )

Earthquake Resistant Construction Subcommittee, CED 39 : 1

*Convener*

DR A. S. ARYA

*Members*

SHRI N. K. BHATTACHARYA

SHRI B. K. CHAKRABORTY

SHRI D. P. SINGH ( *Alternate* )

SHRI D. N. GHOSAL

DR SUDHIR K. JAIN

DR A. S. R. SAI ( *Alternate* )

SHRI M. P. JAISINGH

JOINT DIRECTOR STANDARDS ( B & S ) CB-I

ASSTT DIRECTOR ( B & S ) CB-I ( *Alternate* )

SHRI V. KAPUR

SHRI V. K. KAPOOR ( *Alternate* )

SHRI M. KUNDU

SHRI A. K. LAL

SHRI T. R. BHATIA ( *Alternate* )

DR B. C. MATHUR

DR ( MRS ) P. R. BOSE ( *Alternate* )

SHRI G. M. SHOUNTHU

DR P. SHINIVASULU

DR N. LAKSHMANAN ( *Alternate* )

SHRI SUBRATA CHAKRAVARTY

SUPERINTENDING ENGINEER ( DESIGN )

SUPERINTENDING SURVEYOR OF WORKS ( NDZ )

SUPERINTENDING ENGINEER ( D )

( *Alternate* )

*Representing*

In personal capacity ( 72/6 Civil Lines, Roorkee )

Engineer-in-Chief's Branch, New Delhi

Housing and Urban Development Corporation, New Delhi

North Eastern Council, Shillong

Indian Institute of Technology, Kanpur

Central Buildings Research Institute, Roorkee

Railways Board, Ministry of Railways

Public Works Department, Govt of Himachal Pradesh, Shimla

Hindustan Prefab Limited, New Delhi

National Buildings Organization, New Delhi

University of Roorkee, Department of Earthquake Engineering,  
Roorkee

Public Works Department, Jammu & Kashmir

Structural Engineering Research Centre ( CSIR ), Madras

Public Works Department, Government of Assam, Guwahati

Public Works Department, Government of Gujarat

Central Public Works Department, New Delhi



### **Standard Mark**

The use of the Standard Mark is governed by the provisions of the *Bureau of Indian Standards Act, 1986* and the Rules and Regulations made thereunder. The Standard Mark on products covered by an Indian Standard conveys the assurance that they have been produced to comply with the requirements of that standard under a well defined system of inspection, testing and quality control which is devised and supervised by BIS and operated by the producer. Standard marked products are also continuously checked by BIS for conformity to that standard as a further safeguard. Details of conditions under which a licence for the use of the Standard Mark may be granted to manufacturers or producers may be obtained from the Bureau of Indian Standards.

## Bureau of Indian Standards

BIS is a statutory institution established under the *Bureau of Indian Standards Act, 1986* to promote harmonious development of the activities of standardization, marking and quality certification of goods and attending to connected matters in the country.

### Copyright

BIS has the copyright of all its publications. No part of these publications may be reproduced in any form without the prior permission in writing of BIS. This does not preclude the free use, in the course of implementing the standard, of necessary details, such as symbols and sizes, type or grade designations. Enquiries relating to copyright be addressed to the Director (Publications), BIS.

### Review of Indian Standards

Amendments are issued to standards as the need arises on the basis of comments. Standards are also reviewed periodically; a standard along with amendments is reaffirmed when such review indicates that no changes are needed; if the review indicates that changes are needed, it is taken up for revision. Users of Indian Standards should ascertain that they are in possession of the latest amendments or edition by referring to the latest issue of 'BIS Handbook' and 'Standards Monthly Additions'. Comments on this Indian Standard may be sent to BIS giving the following reference:

Doc No. CED 39 ( 5268 )

### Amendments Issued Since Publication

Amend No.	Date of Issue	Text Affected

## BUREAU OF INDIAN STANDARDS

### Headquarters:

Manak Bhavan, 9 Bahadur Shah Zafar Marg, New Delhi 110002  
Telephones : 331 01 31, 331 13 75

Telegrams : Manaksanstha  
( Common to all offices )

### Regional Offices :

Central : Manak Bhavan, 9 Bahadur Shah Zafar Marg  
NEW DELHI 110002

Telephone

{ 331 01 31  
{ 331 13 75

Eastern : 1/14 C. I. T. Scheme VII M, V. I. P. Road, Maniktola  
CALCUTTA 700054

{ 37 84 99, 37 85 61  
{ 37 86 26, 37 86 62

Northern : SCO 445-446, Sector 35-C, CHANDIGARH 160036

{ 53 38 43, 53 16 40  
{ 53 23 84

Southern : C. I. T. Campus, IV Cross Road, MADRAS 600113

{ 235 02 16, 235 04 42  
{ 235 15 19, 235 23 15

Western : Manakalaya, E9 MIDC, Marol, Andheri ( East )  
BOMBAY 400093

{ 632 92 95, 632 78 58  
{ 632 78 91, 632 78 92

Branches : AHMADABAD. BANGALORE. BHOPAL. BHUBANESHWAR.  
COIMBATORE. FARIDABAD. GHAZIABAD. GUWAHATI. HYDERABAD.  
JAIPUR. KANPUR. LUCKNOW. PATNA. THIRUVANANTHAPURAM.

**AMENDMENT NO. 1    OCTOBER 1995**  
**TO**  
**IS 13827 : 1993    IMPROVING EARTHQUAKE**  
**RESISTANCE OF EARTHEN BUILDINGS —**  
**GUIDELINES**

( *Page 1, clause 1.2* ) — Substitute the following for the existing clause:

**‘1.2 The provisions of this standard are applicable to all seismic zones ( see IS 1893 : 1984 for seismic zones )’.**

( *Page 3, clause 9.1, last line* ) — Substitute ‘IS 2720 ( Part 7 ) : 1980’ for ‘IS 2740 ( Part 7 ) : 1980’.

( *Page 4, clause 10.1.1, lines 4 and 7* ) — Substitute ‘other zones’ for ‘zone III’.

( *Page 4, clause 10.1.7* ) — Add the following matter at the end of the clause:

‘, and 50 percent in zones I and II’.

( *Page 6, clause 11.1* ) — Insert the following matter after the first sentence:

‘Only one such band either below the roof or at the lintel level may be used in zones I and II.’

**AMENDMENT NO. 2 APRIL 2002**  
**TO**  
**IS 13827 :1993 IMPROVING EARTHQUAKE**  
**RESISTANCE OF EARTHEN BUILDINGS — GUIDELINES**

( *Page 1, clause 3.5* ) – Substitute the following for the existing:

**‘3.5 Seismic Zone and Seismic Coefficient**

The seismic zones II to V as classified and the corresponding zone factors as specified in **6.4.2** (Table 2) of IS 1893 (Part 1)’.

( *Page 1, clause 3.6* ) — Substitute the following for the existing:

**‘3.6 Zone Factor (Z)**

It is a factor to obtain the design spectrum depending on the perceived maximum seismic risk characterized by maximum considered earthquake (MCE) in the zone in which the structure is located.’

[ *Page 4, clause 10.1.7 ( see also Amendment No. 1 )* ] — Substitute ‘Zone II’ for ‘zones I and II’.

[ *Page 6, clause 11.1 ( see also Amendment No. 1 )* ] — Substitute ‘Zone II’ for ‘zones I and II’ .

( CED 39 )