

# ANATHEMA



Volume III

December 2017

Issue X

“J. Saunders”  
a poem by Eric King

J. Saunders beats elderly, defenseless men  
There isn't any need or reason to sugar coat it  
Or spruce it up with bureaucratic jargon  
"Used proper force in direction of duty"  
He took his bigoted fist and smashed them  
into the face, ribs and head of an elderly revolutionary  
out of spite and fear and rage  
Saunders exploited a horrifying power dynamic  
Just like countless others in his position have done  
And mauled his insecurities and lack of self-worth  
into Herman, knowing there would be no fight back  
Lest Herman had a death wish  
3 or 4 on one, just like the white gang members  
these pigs wish they could openly be, get yer licks in  
Decades in and still having to deal with this..  
Centuries past and the same old violence  
Saunders kept his job so clearly the state of NY sees no problem with this  
He kept his breathing and bodily functions, which is a certain shame  
How many blows were needed, how much pepper spray dispensed  
to quell his body and spirit?  
How much jealousy rest in Saunder's insect heart  
knowing that Herman is more loved and respected in an hour  
than he will be in his entire life?  
The racism is real, the hate is real, our enemies have names and addresses  
And if you beat our fathers and grandfathers, then you'll have your name called  
and you will have to answer for your actions  
J Saunders is a fucking maggot coward  
We see you biggot, we know you.  
Until All are Free.

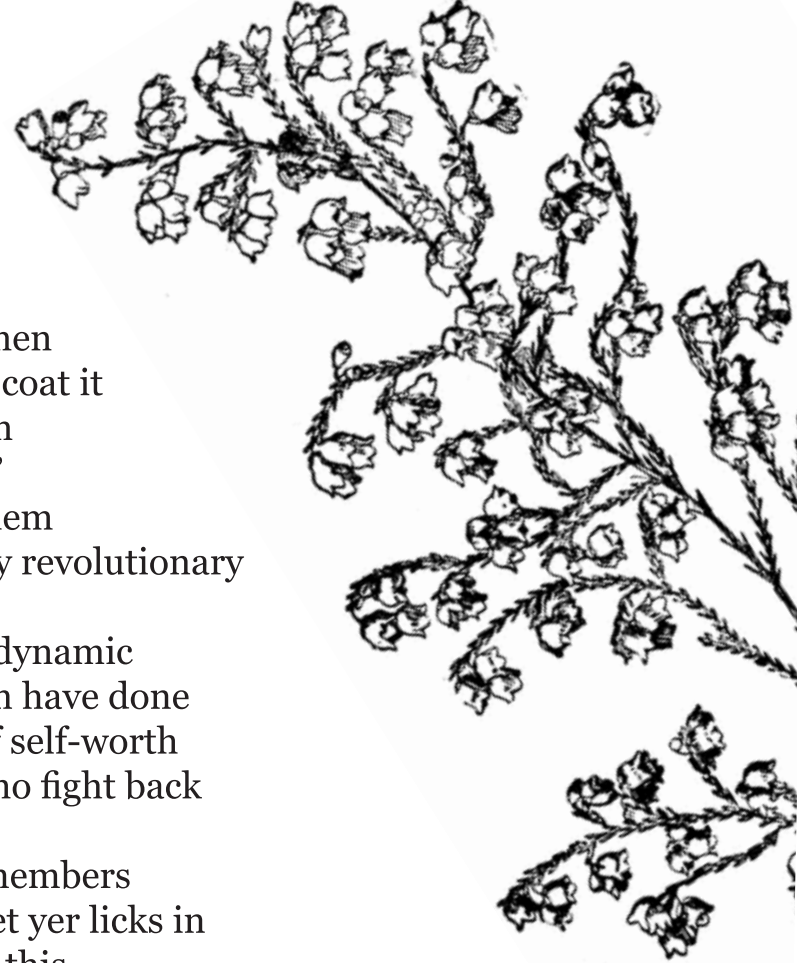

## TABLE OF CONTENTS

WHAT WENT DOWN, p. 2 - FLASH MOBS, p. 2 - PORTRAIT OF A NEO-NAZI, p. 2 - RAIL & ENERGY INFRASTRUCTURE IN PHILLY, p. 3 - GAS PLANT GREENLIT IN NICETOWN, p. 4 - UPDATE ON LOCAL REPRESSION, p. 5 - BLACK DECEMBER, p. 6 - JOHN RAINES, p. 7 - EXCERPT FROM SIGNALS OF DISORDER, p. 8 - AGAINST MORALITY, p. 9 - WORLD NEWS, p. 10 - "J. SAUNDERS" A POEM BY ERIC KING, p. 12

Please visit <http://www.freehermanbell.org/> to learn more about how you can support Herman Bell

## WHAT WENT DOWN

**December 1** - SEPTA officers are attacked when they try to break up a “melee between 100 charter high school students at the 8th and Market-Frankford El station.”

**December 3** - A banner reading “Trump Must Go” is hung in a Philly suburb.

**December 8** - Police officer shot in the leg by his partner officer in North Philly who was attempting to shoot a dog.

**December** - Anti-police graffiti in South Philly.

**December 13** - A cow escapes captivity in a live nativity scene in Old City twice in one morning.

**December 17** - Graffiti in solidarity with Michael Kimble and the Holman Prison rebels spotted in West Philly.

Approximately seven bank robberies have occurred across Philadelphia since we last printed. ★

## FLASH MOBS

So-called flash mobs of local teenagers continue to be one of the most successful threats to the wealthy here in Philly and a potential deterrent to new people moving in. On Saturday, November 18, a group of over 100 teenagers converged downtown at 17th and Walnut and then moved towards 15th and Market. One girl, who was later arrested, allegedly punched and kicked a SEPTA officer, though unfortunately the police said that the officer had not been injured. She is from Juniata Park and a boy who was arrested for allegedly punching someone is from 57th St in West Philly.

Flash mobs’ effectiveness comes from the indiscriminate nature in which they inflict terror. Many people are up in arms about this and attempting to portray Center City as a “diverse” area where the mobs would be targeting all kinds of people who don’t deserve it. Despite this, it is still the neighborhood in which both corporate and individual wealth is most concentrated in the city.

This wealth contrasts sharply with the communities in which the teenagers live.

From 2009 to 2011 in particular, flash mobs posed a regular threat to the city’s hard-won public sense of civility that masks the reality of exploitation and domination in America’s poorest big city. The city retaliated by passing a temporary curfew, intensifying surveillance of social media, starting an online registry of private cameras, and installing cameras on SEPTA.

One mainline resident who had been dining at the Midtown Continental before going to the opera, and had encountered teens banging on the windows of the restaurant, complained that it had been “a threatening situation” and that the idea of visitors to Philadelphia encountering roving mobs “is a disservice, the opposite of attracting people to the city and making them think they can come to the city and enjoy themselves.” ★

## PORTRAIT OF A NEO-NAZI

In mid-December, racist anti-black fliers were found posted around Temple University’s campus. They were quickly torn down by students, staff, and anyone with a healthy distaste for white supremacy. Surveillance footage released by the university police have led some anti-fascists to believe Mark Reardon is behind the fliers. Love City Antifa had this to say:

“There is reason to believe the person who put up racist fliers around Temple campus earlier this week is known white nationalist Mark Daniel Reardon. The images caught on Temple cameras of the person responsible for the fliers bear striking resemblances to photos taken of Reardon earlier this fall at a white nationalist demonstration for Leif Erikson day. The bicycle is the same color and has the same rear guard [as] well as the same handlebars, the person is wearing the same helmet and has the same body type.”

Mark Reardon (aka Illegal Aryan) was exposed last spring after posting neo-nazi fliers on the University of Pennsylvania campus. His exposure led to him losing his job and being evicted from an apartment in West Philly, although he’s suspected of still living somewhere in Philly.

More information on Mark Reardon can be found on [PhillyAntifa.org](http://PhillyAntifa.org) ★

In solidarity with amazon’s fighting workers and in support of Block Black Friday, we attacked three Express vans labeled ‘AZ Amazon’ and ‘drs amazon’ in various ways during the night of November 23 – burned down, stabbed tires, smeared with paint and left the call: ‘strike!’ The white transporters are certainly still in your streets.

– autonomous groups & others –

\*\*\*\*\*

Munich: Amazon Pack Stations Paralyzed

22.11.17: Payback-actions against Amazon. Amazon is one of the biggest trading- and IT- groups in the world. Amazon profits not only with sold goods, but also with the mass accumulation of private data of their

customers, with low payment of delivery subcontractors and with aggressive control of the employees in the dispatch warehouses.

In Munich amazon pack stations were paralyzed. The digital control of employees allows Amazon to perfect its exploitation. By digitally capturing the daily lives of its customers, Amazon wants to calculate their wishes and needs before they are aware of them – and to offer them the corresponding goods. For almost four years Amazon employees have been fighting for more wages and against the destructive working conditions. There is nationwide mobilizations to make protest actions on the 24.11.2017. In solidarity with the fighting Amazon employees, we paralyzed several Amazon pack stations in Munich. Smooth logistics is the prerequisite for Amazon’s ‘Prime’ concept of fast delivery of orders.

We remain unpredictable! Make Amazon pay! ★



## WORLD NEWS

Germany: Attacks Against Amazon in Berlin and Munich  
via Insurrection News

Berlin: Attacks Against Amazon Delivery Vans

23.11.17: We do not want to be governed by information – and to the satisfaction of the manager’s faces, blissfully grinning at the thought of the dull masses who are storming the shops on Black Friday like controlled zombies. In solidarity with Amazon’s fighting workers and in support of Block Black Friday, we attacked three express vans labelled with ‘AZ Amazon’ and ‘drs amazon’ in various ways during the night of November 23 – burned down, stabbed tires, smeared with paint and left the call: ‘strike!’

There was this side note in the media, as once again a ‘terrorist’ was arrested – Amazon proposes the potential terrorist customers in the search for hydrogen peroxide already the next ingredients for the big bang – thanks to the algorithm ...

The basic bet of Amazon and Co. is that with all the feedback-loops, the sensors, microphones, cameras and data, you can not only add value but end up with the technological attack on your body and your actions. There is a twofold of constantly consuming and steering on the one hand and the control and delimitation on the other: let it be the emotion detection with cameras, which already takes place in the shops, smartphones as perceptual aids, Google Home or the scary spy dolls in the nursery.

Consumers of the global flow of goods are supposed to be rewarded for unsolicited emotion capture with personalized and controlled advertising. While on the faces of all those who are up to doing something criminal, the tension may become apparent before the impending shoplifting or shearing, out of the rut of normalization.

In this game, Amazon is at the forefront of poker. So last year Amazon was the company with the most research expenditure worldwide. So there are already test phases with supermarkets without staff. ‘Amazon Go’ relies on customers being registered via app when entering the store, as well as the products that are removed from the shelves – the working customer in the panoptic shop. So soon will also burst the service bubble, the reservoir for

the countless industrial workers.

So we end up with the fighting workers of Amazon, which are already monitored in the panoptic factory at every turn by means of permanently connected with wireless devices in the warehouse.

If it is primarily about the ‘optimization’ of the work processes, it is about two things in the supervised supermarket: on the one hand, to reduce the costs: the working customer, who serve themselves, bravely pays independently, does not need a service staff. On the other hand, it’s about the information which gets generated. Who will stand in front of which shelf and how long? What emotions can be read off the pace? From when do I shop myself happily, when I was previously depressed and slowly walked through the passage?

This is about much more than marketing and product placement, because the online giants are already making almost as much profit through sales and advertising, as with the personal data they are collecting diligently and suggesting life-saving technologies for the whole of humanity. While labour exploitation is almost on a perfect level, profits are now generated through generated data and information of the customers – through access and control of human behavioural patterns and their generated needs: the working customer.

We do not want to be governed by information – and to the satisfaction of the managers’ faces, blissfully grinning at the thought of the dull masses who are storming the shops on Black Friday like controlled zombies.

So we also participate in a labour dispute, although we actually insist on refusing vehemently custom work and trying to keep each others away from it.

The conflict of the striking workers at Amazon represents for us only a part of the gigantic problem of the change of the working world, the isolation of the battlefields and the isolation of the fighting.

And also the strikers will suspect that in ten years there will be no picker and packer anymore, because Amazon is already working on computer-controlled drones to edit the warehouses.

Let’s disconnect the cables  
Let us be more than a zero and a one

## RAIL & ENERGY INFRASTRUCTURE IN PHILLY

An encampment in downtown Olympia recently blocked trains from carrying fracking supplies from the Port of Olympia to the Bakken oilfields in North Dakota for 12 days, while in Pennsylvania, encampments and civil disobedience continue against the Mariner East and Atlantic Sunrise pipelines in Huntingdon County and Lancaster, respectively. Meanwhile, here in Philly, the threat of major new development of resource extraction infrastructure appears to be decreasing, its major fossil fuel refinery teeters on the brink of failure, and shipments of oil via rail have decreased. But the city’s economic reliance on freight transportation of goods and its rampant desecration of the environment continue, and the system’s corresponding weak points remain easy targets, with connections to other ecological and anti-capitalist struggles across the country.

The surge in blockade tactics in recent years, especially of ports and highways during Occupy and in response to police killings, points to how central the logistics of transporting goods has become to capitalist production – and thus how powerful even a brief blockade can be in causing disruptions. As an element of commodity circulation infrastructure, railways have a few obvious weaknesses: they are fixed lines of travel between high-traffic nodes like yards and ports, and have little to no flexibility for re-routing. Almost any point along a high-traffic line is a good place to block. Railways also travel through isolated areas that are relatively hard for their operators or law enforcement to defend or even access.

Railways also have strict procedures regarding disruptions that make even minor clandestine interruptions significant. Flares on the tracks may require trains to stop for up to 30 minutes; blue flags require the crew to stop and assess the safety of the track ahead, which can take substantially more time.

Philly’s public infrastructure – from its rail services to internet connectivity – is widely acknowledged to be

terrible. With 65 operating railroads (the most operating railroads of any state in the country) and 45 choke points in rail traffic across the state of Pennsylvania, development of rail infrastructure has been urgently advocated for the past 15 years, with Philadelphia-area suggested improvements including additions to CSX tracks in the Philly area, building a second main track on CSX’s line from Philly to Trenton, and building a second main track on CSX’s line south of Philly to the Delaware state line.

But proposals for new rail infrastructure have had limited success, especially after the 2008 recession, except for some improvements on CSX lines within Philly itself. Without improvements, 30% of rail corridor miles in the mid-Atlantic region are projected to operate above capacity by 2035, which will exacerbate already existing weaknesses. As far as we know, there is still only one CSX line that goes all the way to Delaware – the track that extends west over the Schuylkill River, via a bridge that crosses over Bartram’s Gardens, and is joined by another track before heading southwest into West Philly – plus the Amtrak Northeast Corridor Line (which gives priority to passenger trains, not freight). There is also only one CSX line that goes all the way north to Trenton – and ultimately, via Albany, to the Bakken shale oil fields in North Dakota.

The Port of Philadelphia, the fourth-largest port in the U.S. for handling imported goods, is now serviced solely by CSX after Norfolk Southern’s departure from the city in 2011. The state, which owns 16 piers and terminals along the Delaware River, many of which have been abandoned or “underused,” recently announced a \$300 million investment in the port, which will allow it to let in bigger ships and be more competitive with other mid-Atlantic ports.

The past few years have seen a resurgence in the importance of rail transportation to the Philly energy industry and economy. Earlier this decade, Sunoco had closed its facilities



in both Marcus Hook and West Deptford, Delaware County; in 2012, its failing refinery in South Philly was sold to the Carlyle Group, with Sunoco remaining a non-controlling partner, and became Philadelphia Energy Solutions, located at 3134 Passyunk Ave.

Around that time, both Sunoco and Sunoco Logistics, its pipeline subsidiary, moved their global headquarters out of the city into the Philly suburbs.

Introducing Bakken shale oil via rail from North Dakota was crucial to the refinery's survival and growth; Philadelphia Energy Solutions became the largest consumer of Bakken oil in the country and the largest refining complex on the eastern seaboard. It is responsible for 72% of the toxic air emissions in Philadelphia.

The rail traffic resurgence resulted from a global oil and gas boom. With few pipelines in place to move oil out of North Dakota, Bakken oil was sold at a steep discount that made it profitable for East Coast refiners to transport it by rail across the country; for a while, Philadelphia enjoyed an unaccustomed market advantage. Rail shipments rose dramatically from 2012-2015, doubling from 2012-2013. At its height, 3 miles of train cars filled with hazardous materials were brought into Philly every day. But oil train traffic leveled off again in late 2015, after global oil prices crashed. The Dakota Access Pipeline, which began functioning in May 2017 after extensive delays, unofficially ended the rail boom to east-coast refineries. The region's oil is now mostly supplied from the Gulf Coast via the Colonial Pipeline, and from shipments to the port from Europe (in which prices are cheaper because of a glut of refineries).

During these blissful years for the city's energy profiteers, one of Philly's schemes to further its capitalist expansion was its plan to become the Philadelphia Energy Hub, which, in the words of Philadelphia Energy Solutions' CEO, Phil Rinaldi, would turn Philadelphia into "The Houston of the East." Rinaldi, a notorious climate-change denier, resigned from PES last year, signaling what now appears to be the continued failure of that plan. But the industry has since moved forward on projects like the Mariner East 1 and Mariner East 2 pipelines, as well as the multi-million dollar conversion of Sunoco's refinery in Marcus Hook into a natural gas processing plant that would take gas directly from the Marcellus shale fields in western Pennsylvania — all of which were part of the projected Hub's infrastructure.

Philadelphia Energy Solutions, meanwhile, is now in severe debt and recently had its credit ratings cut to junk-bond grades. The most recent blow has been a proposal by Buckeye LLC, owner of the Laurel Pipeline, through which PES's oil is taken from Philadelphia to Pittsburgh, to reverse the pipeline's track, cutting Philly off from its Pittsburgh markets. PES's refinery complex is still one of the region's largest employers, and U.S. energy officials have warned that its closure could threaten national security interests.★

## GAS PLANT GREENLIT IN NICETOWN

Late last month, permits for a natural gas-fueled "cogeneration" power plant were approved for 4301 Wissahickon Avenue in the Nicetown neighborhood of North Philadelphia. When SEPTA proposed the plan in the autumn of 2015, it didn't take long for neighboring residents to begin calling into question the possible health impact on their communities. Yet it was only five months after the public comment period, one day before the Licenses and Inspections (L&I) permit was issued, and one week before Air Management Services (AMS) issued their permit, that AMS itself quietly posted a long list of carcinogens likely to be emitted from the plant. Subterfuge on their part, considering that opposition group, Neighbors Against the Gas Plants, says such information was never previously available — in fact, "cancer was never a known health risk until that document was revised."

To say it was never "a known health risk," is to say that it was never acknowledged by those involved in planning and approving the project until that point on November 21st. However, detriment to our health to the point of cancer seems obvious to most who have ever considered the impact of industrial infrastructure on living populations. Mary Morman, a resident of that Nicetown neighborhood nestled between factories, highways and railroad infrastructure — and already suffering from chronic obstructive pulmonary disease — is noted as having expressed her concerns about the power plant's health effects as early as June of 2016 in a philly.com article.

Further concerns involve gas-powered power plants' proven contributions to respiratory and cardiovascular diseases, preterm delivery, low birth weights, eye, nose and throat irritations, headaches, fatigue, nausea, dizziness, skin problems, heart disease, cognitive growth dysfunction for children, dementia and death. Additionally, air pollution from such plants contributes to childhood asthma — a condition that already affects nearly one third of children in that particular area — and it is an energy generation method directly reliant on fracking for its natural gas, thus implicating itself in the risks associated with that gas extraction method as well.

These and other risks, like explosions, are listed in an online petition against the plant, and cite it as the first in potentially many plants like it to be proposed throughout the city.

Cogeneration plants are structures that create both electric and thermal energy that are both functional for the facilities that supply them. The thermal energy supplied is said by those in the industry to be the most important output and requires very high availability and reliability so that none of the industrial processes to which it is supplying thermal

## AGAINST MORALITY

With Christmas cheer bearing down upon us, promoting peace on earth and good will toward men (via consumerism, rather than affection and caring), it may be easy to forget the ongoing wars on freedom by the government, and the lack of goodwill offered to their own citizens in imposing on their so-called civil liberties. There are, of course, few people who question government to the point of necessitating any significant action against it (i.e. to the point of attempting to destroy it), even among anarchists, let alone who question their own obedience. This is the reality inflicted on us through that religious institution of morality, which has long been an attempt to pacify populations. Christmas, with its attendant moral codes, emerged as an important holiday (beginning with the recuperation of pre-Christian traditions, and later with color branding from the Coca Cola company) for the sake of restoring complacency in a war-torn world.

*"The instincts to pity, self-denial and self sacrifice" are "the will turning against life."  
-Friedrich Nietzsche*

These values Nietzsche spoke of strengthen a sense of "human progress, utility, prosperity" and ensure the future of a power that subdues and numbs our sense of self-worth and desire. Even in times when governance is largely separated from any church, the dialogue continues to revolve around dichotomies of "good" versus "evil." In that sense, to examine an individual government, or governments, means ruminating on the systems of value and codes of conduct (for example, submission to authority) that they normalize. It is also socialized and internalized oppressions that govern us, though these also stem largely from official institutions such as government. This suppression of the individual will, through such altruistic asceticisms as pity and self-sacrifice, advocate charity over recognizing the struggle of our peers as our own. Such a recognition would necessitate acting in solidarity against the repressive forces, and in doing so, discarding the normalized rejection of action. These moral values limit the visions and actions that would further our own quest for life.

Even the etymological origins of the "good" come from privileges that arise from class and race distinctions (i.e. noble, aristocratic), along with interpretations of the bible that suggest woman is the ruin of man in Eve's collaboration with the serpent, eating the apple of knowledge after she was born of the rib of Adam.

The journal Baedan: A Journal of Queer Nihilism, tells us: "The Modern English word 'bad' came into common usage about four centuries ago, before which 'evil' was the predominant term. The successor was derived from the Old English derogatory term bæddel, and its diminutive form bæddling, meaning effeminate man, hermaphrodite, pederast. This in turn was derived from bædan, meaning to defile."

Responses to this, as most oppressions, tend toward the

reactionary; we try to reappropriate terminology and seek revenge — not the worst course, if these were means to grow independently and keep authorities at bay for fear of repercussions. But such a course ultimately tries to skew or reverse the moral code, thus creating a new morality, much the way the judeo-christian tradition once inverted the paradigm to celebrate the slave, the meek, the complicit. This tendency toward immorality, again, is not bad (as that would reinforce this moralizing dilemma), but a more appropriate course would tend toward amorality — that is, realizing our own desires and acting on them regardless of imposed moral codes, and only acting against them when they interfere with said course.

Unfortunately, this is mostly considered impossible for some, or at least terribly short-lived. Some level of compromise with normative society is often necessary for the anti-capitalist to prevent their imprisonment or murder by the state, though there are many romantic stories of the brilliant but short lives of those that dared to live that way. But in addition to it being difficult to realize this amorality (because of our lack of will, conditioning that blinds us to our own desires, and policing forces), there is often a lack of means for those of us who find wild spaces desirable (because of property rights and deforestation). Hence a sympathy develops for an "active" nihilist position that seeks a vengeful destruction (or at least a defiling) of any human-erected edifice.

But these are more often excuses that fail to acknowledge our own power. We blame others for our misfortune, without attempting to act on the level necessary to overcome it; meanwhile, we maintain the limiting dichotomy born of morality by referring to our overlords as "evil." It is a slave morality, in fact, prudent to maintaining systems of governance, that celebrates passivity as happiness and writes off the actualization of our desires as selfish.

Happiness should be an action. Much like activities such as listening are better when done actively, we can begin to realize the relationship of activities like insurrection with joy. To quake and vibrate out of the hands that hold us down with a vigorous, uncommodifiable *jouissance*; that life-giving autonomy and orgasmic joy that the journal Baedan advocates. Short of that, we are left with a totally inescapable domestication, that ongoing war on life, leaving us with one last dichotomy — total submission or the absolute destruction of every human element.

So let us "destroy laughing," as Novatore once did, accepting neither aristocratic nor slave moralities. Act in the immediate, refusing to wait for a demonstration to be planned, nor for anything else — for we are only what we decide to be. Let's invert the paradigm, refusing to ignore the ongoing war and take it on at its own level. Channel Joseph Dejaque: "Forward everyone! And with arms and heart, word and pen, dagger and gun, irony and curse, theft, poisoning and arson, let's make...war on society!" ★

They then drove in Dr. Raines's station wagon to a farmhouse in nearby Pottstown, where, over beer and sandwiches, they pored over the documents.

"It didn't take us long to discover we had not acted in vain," Dr. Raines recalled.

Among the files was an F.B.I. order to interview dissidents aggressively. The bureau's goal, the order said, was to "enhance the paranoia endemic in these circles" and "to get the point across there is an F.B.I. agent behind every mailbox."

What that proved, Dr. Raines said, was that J. Edgar Hoover, the F.B.I. director, "was not simply into surveillance; Hoover was into taking the voice of dissent away from dissent."

The cache also included a routine routing slip with the word "Cointelpro." The burglars overlooked the document, but the Church Committee later exposed the program in detail.

At dawn, Ms. Raines drove her husband to a gas station pay phone, where he called a Reuters reporter and announced that the burglary had been committed by a group calling itself the Citizens' Commission to Investigate the F.B.I.

The burglars copied the documents and sent them to Senator George S. McGovern of South Dakota and Representative Parren J. Mitchell of Maryland, and to The Post, The New York Times and The Los Angeles Times.

The gang never convened again. In 1976, the statute of limitations for burglary charges expired.

John Curtis Raines was born on Oct. 27, 1933, in Minneapolis. As a son of privilege who had been raised by a governess in a house with five fireplaces and seven bathrooms, Dr. Raines experienced a social-conscience epiphany on a trip to the South with other civil-rights advocates in the early 1960s, when, he was thrown in jail for trying to integrate a bus station in Little Rock, Ark.

"For the first time in my life," he said in a 2011 oral history interview for the Temple University Libraries, "I found myself in a space I had never been before — outside power and regarded by power as an enemy, and power had the power to punish me for that." ★

*an excerpt from the text*

**Signals of Disorder:  
Sowing Anarchy in the Metropolis**

Spreading signals of disorder accomplishes a number of things. It increases our tactical strength, as we hone a practice of vandalism, property destruction, public occupation, and rowdiness.

It interrupts the narrative of social peace, and creates the indisputable fact of people opposed to the present system and fighting against it. It means the reason for this fight, the anarchist critiques, have to be taken more seriously because they already exist in the streets. In this way, the attacks create the struggle as a fact in a way that would otherwise only be possible in times of greater social upheaval and movement. To have this effect, the signals of disorder need to explicitly link themselves to a recognizable social practice, one that would otherwise be ignored or chopped up into disconnected eccentricities of lifestyle. People in the neighborhood must know that the graffiti and broken windows are the doing of "the anarchists" or some other group that has a public existence, because signals of disorder that can be isolated as phenomena of urban white noise can be legitimately and popularly policed with techniques reserved for inanimate objects and aesthetic aberrations; they would rub us off the streets with the same chemical rigor as they clean graffiti off the walls.

Signals of disorder are contagious. They attract people who also want to be able to touch and alter their world rather than just passing through it. They are easy to replicate and at times, generally beyond our control or prediction, they spread far beyond our circles. They allow us, and anyone else, to reassert ourselves in public space, to reverse commercialization, to make neighborhoods that belong to us, to create the ground on which society will be reborn.

In a neighborhood where the walls are covered with anarchist posters, beautiful radical graffiti stands alongside all the usual tags, advertisements never stay up for long, the windows of luxury cars, banks, and gentrifying apartments or restaurants are never safe, and people hang out drinking and talking on the street corners and in the parks, our ideas will be seriously discussed outside our own narrow circles, and the state would need a major counterinsurgency operation to have just the hope of uprooting us.

Whenever we can break their little laws with impunity, we show that the State is weak. When advertising is defaced and public space is liberated, we show that capitalism is not absolute.

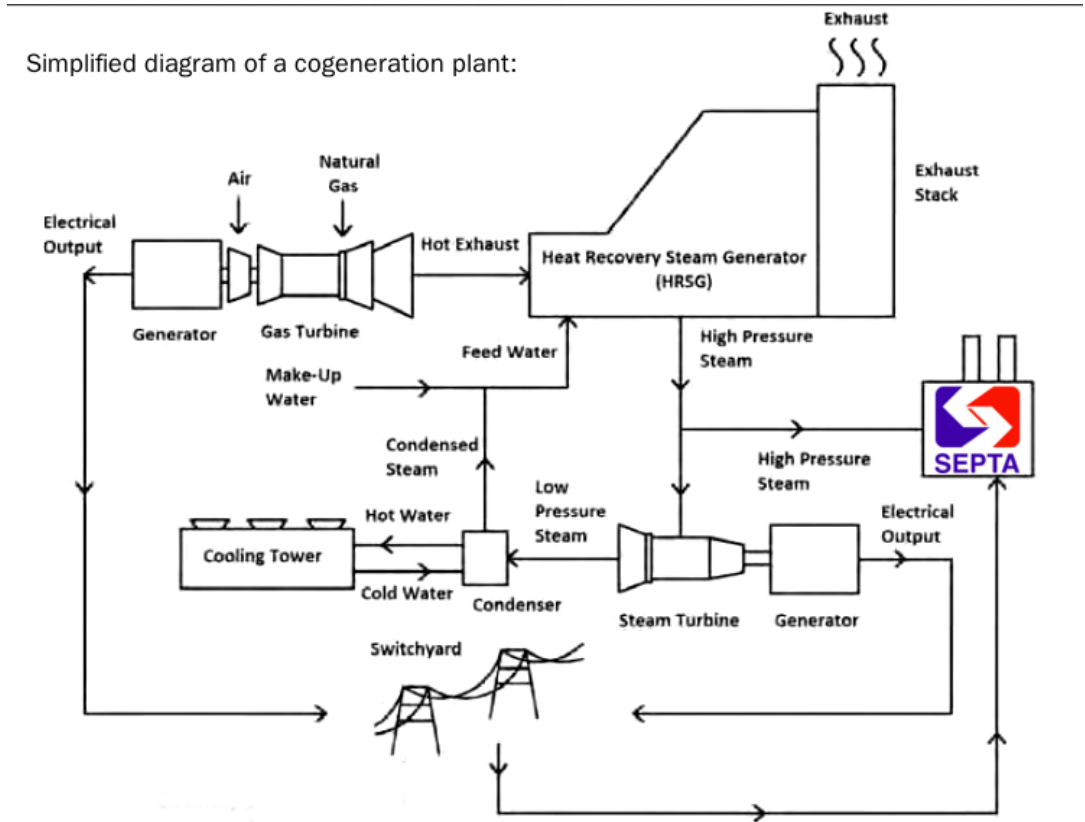

energy are interrupted. This causes cogeneration plants to have far less control of start-ups or shutdowns as compared to a plant generating only electricity. Also, it limits the opportunities for many cogeneration plants to either increase or decrease their energy generation, which can be significant in cyclical demand fluctuations that occur with the seasons. Additionally, as an industry insider said at a conference last year, it "is not that much more efficient."

Ironically, Erik S. Johanson (SEPTA's director of business innovation) suggests that being "prepared for what a crazy weather future looks like," by being energy-independent in a climate-changing world, is the reason to create a greenhouse gas-generating plant. The power plant is to be built alongside an already existing SEPTA train yard and bus garage, where there are a great deal of security measures and several entry points for materials by truck and train already in place.

Noresco LLC has been chosen to draw up the plans for the plant — they have local offices at 1650 Market Street on the 36th floor, and are also involved in building prison infrastructure in other states. The final approval of the plant by SEPTA was ushered in unanimously last year by the eleven board members in attendance, despite the vocal attempts by climate activists to disrupt the meeting. Those board members that passed the measure are Pasquale T. Deon, Thomas E. Babcock, Beverley Coleman, Robert D. Fox, Kevin L. Johnson, John I. Kane, William J. Leonard, Charles H. Martin, William M. McSwain, Clarena I.W. Tolson, and Michael A. Vereb. SEPTA's headquarters is located at 1234 Market Street, downtown. ★

**UPDATE ON LOCAL REPRESSION**

State retaliation continues against the two people arrested on May 1 for being in the vicinity of the attacks that night against luxury condos and cars in a gentrifying area of Northern Liberties/South Kensington. Following the formal arraignment hearing, none of the charges — which include the felonies "causing a catastrophe" and conspiracy to riot — have been dropped. The scheduling conference to set the trial date has now been postponed four times. One of the defendants has requested support; to donate funds and send support their way, please email [phlbailfund@riseup.net](mailto:phlbailfund@riseup.net).

Meanwhile, the person charged with vandalizing the mural of notoriously racist former mayor and police commissioner Frank Rizzo is awaiting trial. The Mural Arts Program — which commissioned and maintains the mural — has claimed that the damage to the mural cost around \$9,200, meaning that the defendant is now facing two felony charges and up to 7-16 years in prison.

## BLACK DECEMBER

Because we are internationalists, and recognize no borders, we want to share this call locally. But to add further context, it was on December 15th, 2014 that Brandon Tate-Brown was murdered by two police officers here in Philly. According to members of his family, Tate-Brown was really murdered for “driving while black.”

A witness who approached the officers after the shooting said one told him they stopped Tate-Brown “for a vehicle that was described in a robbery earlier.” But Officer Heng Dang, involved in the murder, told Internal Affairs investigators that he pulled over Tate-Brown because he drove with just his daytime running lights on. The Police Department has also maintained that Tate-Brown was shot as he reached into the passenger side of his car, possibly trying to retrieve a stolen, loaded, hidden handgun Officer Nicholas Carrelli claims to have spotted earlier jammed into the center console. But in his statement to Internal Affairs, Carrelli said he opened fire when Tate-Brown ran around the trunk of the Charger, “before he gets to the roof of the car.”

### Worldwide: Call for a Black December!

Received and translated by Insurrection News

With the anarchist Sebastián Oversluij in our memory, four years since his death in combat in Chile during an attempted bank appropriation in December 2013.

With swollen hearts, remembering the anarchist comrade Alexandros Grigoropoulos, seven years since he was murdered in Exarcheia, Greece by police bullets in the year 2008.

For a Black December!

While democratic and civilized totalitarianism advances, expanding its control and surveillance mechanisms, devastating territories, attacking liberated spaces and hunting down insurgents throughout the world, imposing punishments and long sentences of imprisonment against the enemies of domination.

While in Italy our comrades are launching blasphemous attacks against the judges and reaffirming their anarchist convictions during the trial by the repressive operation Scripta Manent.

While thousands of prisoners in struggle are mobilizing in Greece in response to the attempts of the power to asphyxiate prisoners with a new penitentiary code.

While in Chile the power tries to strike its blow of revenge demanding long sentences in the trial against the anarchists

# SUPPORT VAUGHN PRISONERS

<b>JONATAN RODRIGUEZ</b> DOB: 0005/2013 Sussex Correctional Institution P.O. Box 500 Georgetown DE 19947	<b>LAWRENCE MICHAELS</b> DOB: 00/14/1986 Sussex Correctional Institution P.O. Box 500 Georgetown DE 19947
<b>ABEDNEGO BAYNES</b> DOB: 05/20/1992 Sussex Correctional Institution P.O. Box 500 Georgetown DE 19947	<b>JANIS MATHIS</b> DOB: 04/24/1992 Howard R. Young Correctional Facility P.O. Box 9561 Wilmington, DE 19809
<b>ROBERT HERNANDEZ</b> DOB: 09/25/1981 Howard R. Young Correctional Facility P.O. Box 9561 Wilmington, DE 19809	<b>DERWAYNE STANTIS</b> DOB: 11/10/1961 Howard R. Young Correctional Facility P.O. Box 9561 Wilmington, DE 19809
<b>JARREAU AYERS</b> DOB: 06/15/1981 Sussex Correctional Institution P.O. Box 500 Georgetown DE 19947	<b>ALEJANDRO RODRIGUEZ GORTIZ</b> DOB: 12/17/1989 Howard R. Young Correctional Facility P.O. Box 9561 Wilmington, DE 19809
<b>OBADIAH MILLER</b> DOB: 08/04/1992 Howard R. Young Correctional Facility P.O. Box 9561 Wilmington, DE 19809	<b>PEDRO CHAIREZ</b> DOB: 02/17/1975 Sussex Correctional Institution P.O. Box 500 Georgetown DE 19947
<b>JOHN BRAMBLE</b> DOB: 09/01/1989 Sussex Correctional Institution P.O. Box 500 Georgetown DE 19947	<b>DERIC FOHNEY</b> DOB: 02/06/1989 Howard R. Young Correctional Facility P.O. Box 9561 Wilmington, DE 19809
<b>KEVIN BERRY</b> DOB: 07/17/1990 Howard R. Young Correctional Facility P.O. Box 9561 Wilmington, DE 19809	<b>KELLY GIBBS</b> DOB: 10/01/1988 Sussex Correctional Institution P.O. Box 500 Georgetown DE 19947
<b>COREY SMITH</b> DOB: 07/14/1985 Howard R. Young Correctional Facility P.O. Box 9561 Wilmington, DE 19809	<b>ROMAN SHANKARAS</b> DOB: 01/31/1987 Sussex Correctional Institution P.O. Box 500 Georgetown DE 19947
<b>LUIS SIERRA</b> (Abdul Haq El-Qader) DOB: 02/19/1986 Sussex Correctional Institution P.O. Box 500 Georgetown DE 19947	<b>ROYAL DOWNS</b> DOB: 02/13/1965 Howard R. Young Correctional Facility P.O. Box 9561 Wilmington, DE 19809

On February 1, 2017, inmates at the James T. Vaughn Correctional Center (JTCC) in Delaware took control of their unit and held staff hostage in an uprising that lasted eighteen hours. They called the media, released a list of demands, and explained their actions as motivated by their conditions of confinement as well as the election of Donald Trump as President. One prison guard, Steven Floyd, was killed by inmates during the uprising.

Sixteen prisoners are now facing first degree murder charges and two others are facing other charges related to the riot. Please take a moment to share your solidarity with those facing repression. Use these addresses to write letters to these eighteen prisoners.

Addresses current as of 11/2017

*“We have patience, a lot of time, and most importantly nothing to lose.”*  
— a prisoner at the James T. Vaughn Correctional Center

Juan Flores, Nataly Casanova and Enrique Durán.

While in Argentina where you can still feel the rage and pain from the murder of comrade Santiago Maldonado, and then the police murdered the Mapuche warrior Rafael Nahuel while the government militarizes its territories in preparation for the next G20 summit.

While in Brazil, police intelligence tries to halt the anarchist struggle via Operation Erebo, accusing comrades, anarchist spaces and libraries of being behind the beautiful incendiary flashes that in recent years have spread in an intentional way against political party headquarters, police barracks and various power structures.

While all this is happening, in various parts of the globe anarchic minds explore practical and offensive responses to the constant aggression that represents the very existence of power and authority.

From the dignity of the prisoners struggling in the prisons of Bulgaria, to the burning cars in France and the call to action in the Czech Republic. From Belarus to Australia, from

Mexico to Belgium and Germany. From Bolivia to the United Kingdom, Finland, Russia, Indonesia, Spain and the whole world, the yearnings for freedom are expressed, shouted, conspired and acted upon without bosses or hierarchies, opening the way to anarchy here and now.

That’s why December continues to be an invitation for insurgent communication via the wild heat of the offensive action against power.

For all our imprisoned and persecuted comrades. For all those that rise up and take action against domination by attacking their structures and their representatives.

May solidarity with our comrades become action. May the memory of Sebastián Oversluij and Alexandros Grigoropoulos ignite barricades and feed fires and explosions against power and their defenders. Let the enemy feel the siege of revolt in every neighbourhood, in every cell and on every corner.

For a Black December, long live anarchy! ★

## JOHN RAINES, 84, WHO EVADED CAPTURE IN AN F.B.I. BREAK IN, DIES

One day in May 1971, John C. Raines, a religion professor at Temple University, had just returned to his home in Germantown, Pa., from playing tennis when two F.B.I. agents knocked on the door.

For weeks, hundreds of agents had been combing Philadelphia for the amateur burglars who had embarrassed the F.B.I. by raiding a suburban field office and stealing a thousand files, and then baffled the bureau by evading capture.

The documents were delivered anonymously to journalists and congressmen as proof that the bureau had systematically and illegally infiltrated, intimidated and disrupted protest groups. The two agents asked whether Dr. Raines, who, with his wife, Bonnie Raines, was known as an antiwar protester, could help identify the culprits.

Startled by the question, Dr. Raines needed time to deliberate. He excused himself to shower. When he returned downstairs, he coolly took the offensive.

“I’m so angry about what I’ve been reading in the press about the F.B.I. and the abuses that have taken place that I’m not going to talk to you about any of it,” Dr. Raines said to the agents, his wife recalled on Thursday. “I’m not going to make your job any easier.

I’m not going to answer your question.”

For nearly two decades, no one from the government asked him the question again. And so no one learned that he had been one of eight antiwar activists, including his wife, who took part in the burglary — and that he had driven a getaway car, the family station wagon.

As he hid in plain sight, Dr. Raines remained mute about the episode, the couple’s last protest against the war in Vietnam.

“We didn’t need attention, because we had done what needed to be done,” he said.

The burglary, and subsequent lawsuits, prompted a groundbreaking investigation in 1975 by the so-called Church committee, a special Senate panel led by Senator Frank Church of Idaho. The committee revealed details of the F.B.I.’s secret Cointelpro, or counterintelligence, operation, which included illegal sabotage of dissident groups deemed to be subversive.

Dr. Raines died on Sunday November 19, here in Philadelphia, at age 84.

The burglary, on March 8, 1971, was conceived by Professor William C. Davidon of Haverford College in Pennsylvania and plotted in the Raineses’ attic. At first, Dr. Raines was incredulous.

“After the chin came off the floor and we started talking about it,” he told The Temple News in 2014, “it seemed more and more plausible.”

The eight conspirators, five men and three women, ranged in age from 20 to 44 and included another professor, a graduate student, two recent college dropouts and Ms. Raines, who worked in a day care center. She scoped out the office, pretending to be a Swarthmore student researching the bureau’s receptivity to hiring women.

The couple enlisted Dr. Raines’s brother to care for their three children, all younger than 10, if they were caught and imprisoned.

Wearing gloves and armed with a lock pick and a crow bar while potential witnesses in the building were preoccupied watching the Joe Frazier-Muhammad Ali heavyweight championship fight, the burglars spent 45 minutes stuffing files into suitcases. Ms. Raines waited in a car, ready to block the street if the police arrived.