

SPECIAL SOURCE OPERATIONS
BLARNEY
 Enter Keywords All Files
 SSO THE MOVIE PLAY

▼ (U) Contact Information

(U//FOUO) Special Source Operations Front Office

Building: [REDACTED]
 Room: [REDACTED]
 Secure: [REDACTED]
 Black: [REDACTED]
 Suite: [REDACTED]

Welcome, [REDACTED]

[My Profile](#) [REDACTED]
[My Activity Viewer](#)

▼ (U) Divisions

(U//FOUO) S3531 - Program Management Division

▶ (U//FOUO) S3532 - Engineering & Technical Services Division

▶ (U//FOUO) S3533 Operations & Discovery Division

▼ (U) Special Activities

(U//FOUO) Configuration Management

(U//FOUO) Management Review Board

(U//FOUO) Engineering Review Board

(S//REL) SSO and Cybersecurity

(S//SI) Endpoint-Midpoint Collaboration

(U//FOUO) SSO Compliance

(U//FOUO) SSO Metrics

Home Projects Documents Configuration Management

[Request Access to PRISM Web Page](#)



▼ (U) General Information

YEAR ESTABLISHED	(U) BLARNEY has been in existence since the early 1970s. In 1978, the program came under the authority of the Foreign Intelligence Surveillance Act (FISA).
DESCRIPTION	(TS//SI//NF) BLARNEY is an ongoing collection program that leverages IC and commercial partnerships to gain access and exploit foreign intelligence obtained from global networks. The program operates under the authorities of NSA FISA, FBI FISA and FAA.
INTELLIGENCE VALUE	(TS//SI//NF) BLARNEY is the leading source of FISA collection, producing over 11,000 reports and is consistently a top contributor to the President's Daily Brief; The program contributes to over 60% of product reporting for the CounterTerrorism Product Line and over 80% of the overall FAA reporting;
MAJOR TARGETS	(TS//SI//NF) Diplomatic establishments, Counterterrorism, Foreign Government and Economic
MAJOR BENEFACTORS & USERS OF INFORMATION	(TS//SI//REL TO USA,FVEY) Analysis and Production (Counterterrorism); Executive Branch, CIA, Military Commands, Policy Makers

▼ (U) Program Management Office

Name	Title
[REDACTED]	Program Director

MISSION SUPPORT HUB

SWO On Duty: [REDACTED]

MSH Phone: [REDACTED]
Email SWO Alias: [REDACTED]

SSO ACCESS STATUS

- Corporate
- Unilateral
- Foreign
- Other

[System Outages](#)

▼ (U) For the Analyst / Engineer

- (U//FOUO) SSO Customer Advocate
- (U//FOUO) SSO SIGAD Index
- (U//FOUO) Finding General Access Info
- (U//FOUO) TWISTEDPATH
- (U//FOUO) SSO Dashboard
- (U//FOUO) Access Trigraph Master List
- (U//FOUO) What's on Cover (WOC)
- (U//FOUO) BROKENRECORD
- (U//FOUO) Previous Fiber Reports
- (U//FOUO) Zip Code Exclusions (RAM-A Sites)
- (U//FOUO) Controlled System Access

(U//FOUO) BLARNEY PROGRAM TDY HANDBOOK
A Guide For Traveling To Sites (U//FOUO)
As of 15 April 2011

(U) The purpose of this TDY Handbook is to provide the BLARNEY Traveler with the proper procedures and guidelines when traveling on official business, either local or CONUS, in support of the BLARNEY Program. This information is applicable to all BLARNEY team members who travel or have the potential to travel.

(U) General Authority (U):

(U) Locally: Governed by SSO Office and Program Travel Policy and Processes.
(U//FOUO) In Country: As directed by Program Director or delegate.

(U) SSO Required Courses, Briefings, or Procedures: (U)

(U) In accordance with SSO Travel Training Requirements for CONUS TDYs:

OHES1108	Heartsaver (4 hours)
SOST2209	Basic Sensitive Ops (40 hrs)
CIAT2101	Elicitation Techniques (8 hours)

(U) Check Out/In with SSO Security (Travel Alias)
SSO webpage (go S353)
[REDACTED]

(U) Check in with Program Director

(U) Program Recommended Courses: (U)

(U) As directed by the Program Director or delegate.

(U) Cover Travel (U):

(C) Defense Management Technology Services Office (DMTSO) – required cover, as traveler is not to overtly identify himself/herself as an employee of the National Security Agency or a member of the intelligence community. Traveler must attend a cover briefing from S444 (Special Operational Support) once a year, or prior to the TDY. **Note: If special arrangements need to be made, please call [REDACTED]. Each situation will be considered as needed.

(U) Helpful Links for country information / TDY documents: (U//FOUO):

NSA (Ft. Meade):

NSAnet LL42 Corporate Travel Services (go travel)
[REDACTED]

U.S. Department of State Travel Page:

NSAnet (travel page): [REDACTED]

U.S. Department of State country page:

NSAnet: [REDACTED]

Derived From: NSA/CSSM 1-52

Dated: 20041123

Declassify On: 20291123

Internet: <http://www.state.gov>

(U) General Information (U):

(C) The BLARNEY Program has sites or partner organizations mostly located in the MD/DC/VA Metropolitan area and New York and occasionally NJ. When traveling to sites in the DC Metropolitan area, the BLARNEY cover vehicles should be used. When transporting or picking up equipment in the NY or NJ area the BLARNEY cover vehicles with NY tags should be used. Otherwise, travel to New York is normally done by train and will require a Request and Travel Authorization Expense Report (RTA). Attire depends on the type of venue; for meetings the attire is usually business casual. No military uniforms or NSA Badges should be worn.

(U) Visits to Partner Organizations and Field Sites (C):

(U) NOTE: FOR ALL VISITS (U)

- (1) (U) Ensure clearances are sent to the appropriate Security/Technical POCs at the partner organizations and/or sites. Please see PD or D/PD for updated contact information.
- (2) (U) Get directions to facility from PD, D/PD, MPM or ETS System Engineer.
- (3) (U) Get approval from PD or D/PD if you are a contractor.

A. (U) Artifice, Serenade, and Rocksalt (in Virginia) Lithium (in Maryland) (C).

1. Coordinate visit with partner points-of-contact 24-48 hours prior to visit:
2. When entering facility:
Check in/Sign in at front desk with:
Name: **Self**
Phone: **Personal phone number**
POC: **Meeting POC**
3. When entering SCIF:
Sign in with Name/Date/Time/Clearance Level

B. (U) FBI Headquarters (DC) (C)

1. Coordinate visit with point-of-contact(s) 24-48 hours prior to visit.
2. When entering facility, check in at the front desk in the visitor center
Have identification available to show the guards
Walk through screening area
Enter visitor control center
Show identification and sign sheet. If asked your organization is DOD
Give the name of your meeting POC who will come there to pick you up.

C. (U) FBI ERF (Quantico, VA) (C)

1. Coordinate visit with SSO/BLARNEY representative (POC) at ERF 24-48 hours prior to visit. If given enough notice, the POC will submit a visit request for you.
2. At the Marine checkpoint show your drivers license and tell them you are going to the FBI Academy.
3. Once at the Academy entrance, you have two options.
 - (a) If a visitor request was submitted for you, give the FBI Police officer some form of identification which they will use to look up the VR and allow you through.
 - OR
 - (b) If no visitor request was submitted, you can show them your IC Badge and tell them you are going to ERF.
4. At the gate arm just outside the parking lot, press the button to call Security and tell them you are there for a meeting at DITU.
5. Once inside the building, give the guard a form of identification. They will issue you a visitor badge and contact your POC who will meet you there.

D. (U) Titan Pointe (FBI New York Field Office) (C)

1. Coordinate with NSA POCs to include [REDACTED] Blarney PD or delegate and [REDACTED] (TP POC) at least 1 week prior to visit. TP POC will be responsible for notifying FBI site watch officer of any visitors.
2. After internal SSO approvals coordinate visit with TP point-of-contact(s) 24-48 hours prior to visit:
3. When approaching facility:
 - Ring the buzzer and wait for admittance
 - Ask for POC who will meet you in waiting area
 - Sign in as required
 - Sign out as required

E. (U) Queensland (FBI Washington Field Office) (C)

Restricted access. See Blarney PD.

(U) Courier Procedures (U):

(U) Transporting classified material outside the DC Metropolitan area should be kept to a minimum since most information can be forwarded electronically. Classified materials should

be appropriately wrapped and secured in an approved lock bag, unless size constraints prohibit their use. Occasionally travelers will be asked to transport items and/or equipment to and from partner and other sites. For equipment transports, the equipment should be appropriately wrapped and appropriate property accountability paperwork completed. Anyone couriating classified material must have a current courier briefing on file.

(U) TRAVEL PLANNING (U):

(U) To travel by train, LL42 Corporate Travel Services (go travel) can assist with train ticket reservations, RTAs, travel security briefings, etc.

(U) COVER VEHICLES:

(S//SI) Note: Operational use of the vehicles takes priority over any/all other requirements. These vehicles are for “Official Use Only” to include the transport of NSA personnel and equipment. These vehicles are solely for the use by personnel who actively support NSA/FBI programs. These programs currently include: BLARNEY, FAIRVIEW, STORMBREW and OAKSTAR.

(U//FOUO)

NOTE: The BLARNEY Cover Vehicle SOP is currently under revision and the link will be provided as soon as the document is approved. For immediate guidance, please see PD, D/PD, or [REDACTED] who is POC for vehicle reservations and tracking.

(U) Cover Stories (U)

(C) When traveling to the partner’s facility or other program sites, family members and co-workers (who are not cleared), can be given generic travel plans, i.e., ”Going to Baltimore, MD to do H/W and/or S/W Engineering”, and/or “will be in Baltimore, MD for the day at another company”. Provide family members/co-workers with cell phone/hotel phone numbers to reach you at and to leave messages for you. Also give your family a co-worker’s (not on TDY with you) phone number so that if there is an emergency at home, your family can contact your co-worker who can then contact you at the facility.

(U) Multicultural Awareness (U) N/A (All travel in support of BLARNEY is CONUS)

(U) TDY Pre-Brief (U):

(U) PD or D/PD will coordinate this meeting. It should be held at least two weeks prior to TDY. Everyone directly supporting the system will attend.

(U) TDY De-Brief (U):

(U) If required, PD or D/PD will coordinate this meeting. Selected travelers supporting the system will attend.

(U) Post TDY Trip Report (U):

(U) Timeline and content as directed by PD or D/PD



Dataflow Diagrams

April 2012

Note: Please refer to previous diagrams for decommissioned systems.

Derived From: NSACSSM 1-52
Dated: 20070108
Declassify On: 20361101

FAA Voice/Fax/Modem DNR&VoIP

Access-Partner Processing

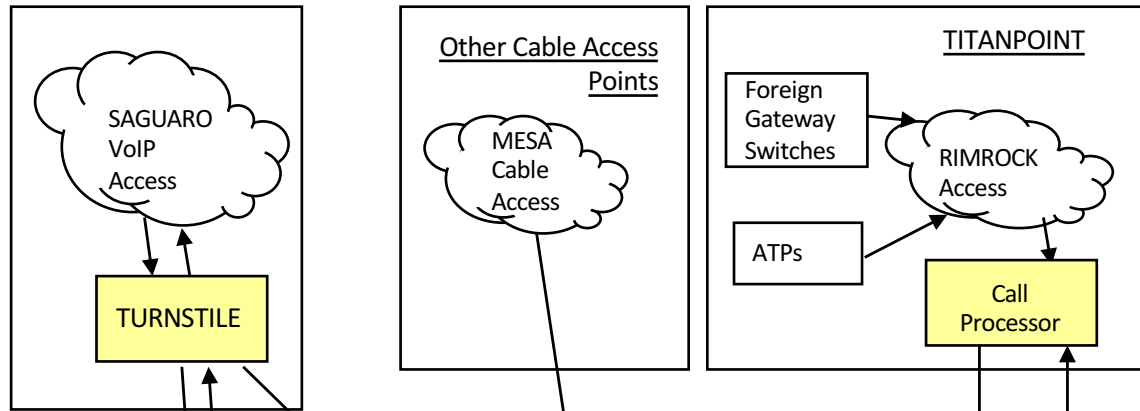

SIGAD: US-984X2

PDDG: 29

CASE Root: SSO CASNs, XM*

To BL Routing Designator: FLV, FLU, FLF, FLD

To Customer Routing Designator: BAV(Voice),LST (Fax), VFG (Modem), BAE (Failed Modem or Fax to Josy)

Data Classification: TS//SI//NF// RGT-A or RGT-C

Data Type: DNR (USSID 126, CSDF)

Authority: FAA

Source System Digraph: RR, UA

Partner Controlled (Yellow box)
NSA Controlled (Orange box)

Site Processing

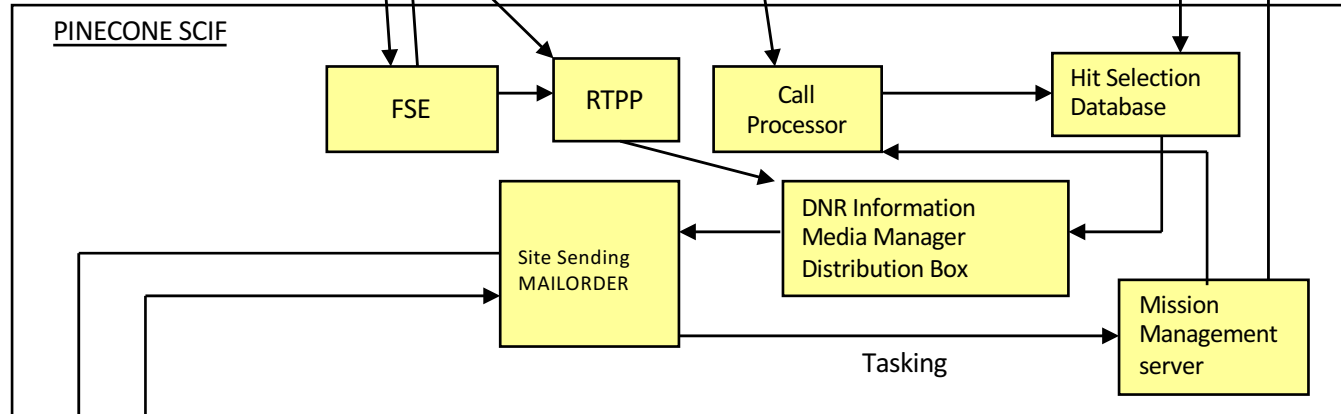

Corporate Processing - NSA

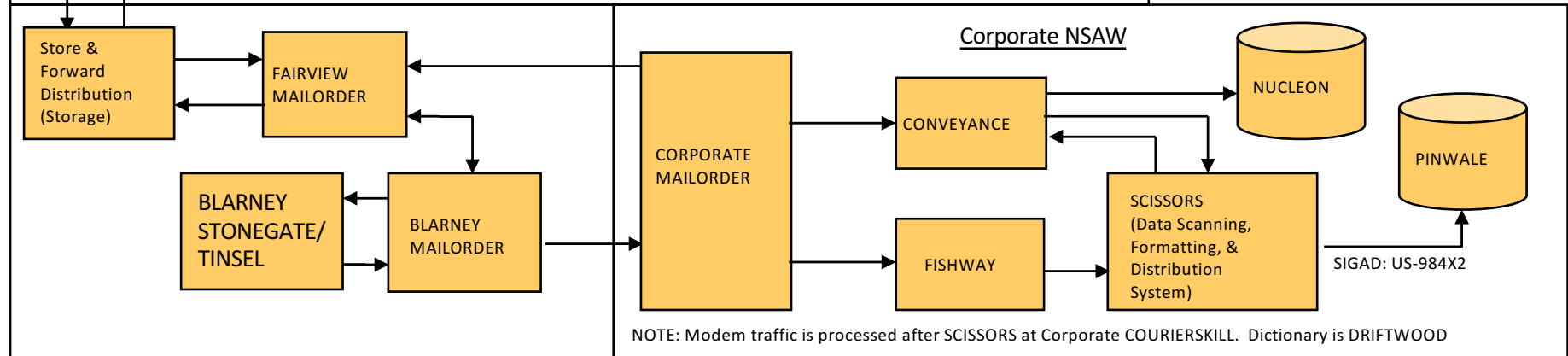

SIGAD: US-984X2

FAA SMS

Access-Partner Processing

Site Processing

Corporate Processing - NSA

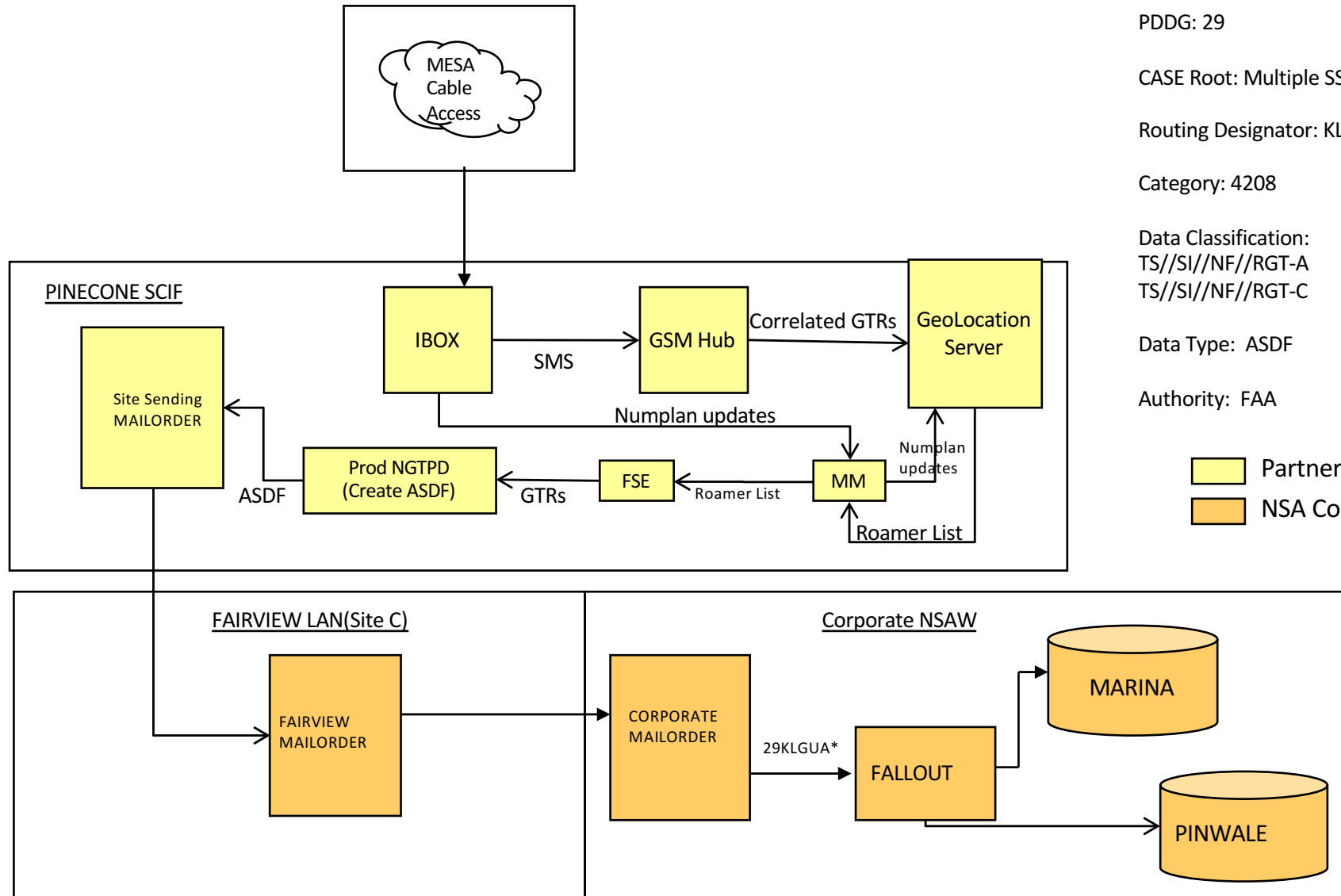

SIGAD: US-984X2

PDDG: 29

CASE Root: Multiple SSO CASNs

Routing Designator: KLG

Category: 4208

Data Classification:
TS//SI//NF//RGT-A
TS//SI//NF//RGT-C

Data Type: ASDF

Authority: FAA

Partner Controlled
 NSA Controlled

*** Currently Inactive***

FBI FISA Voice/Fax/Modem DNR&VoIP

Access-Partner Processing

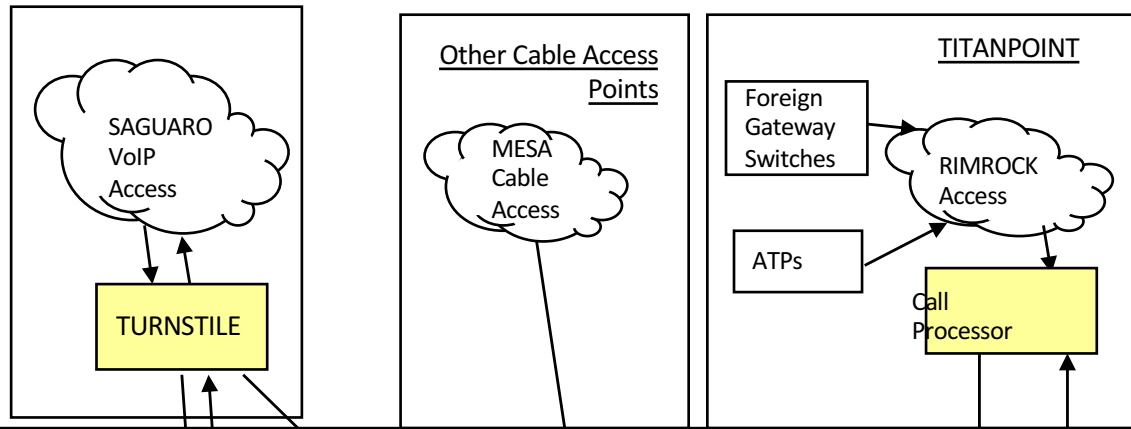

SIGAD: US-984J2

PDDG: AX

CASE Root: SSO CASNs, XM*

To BL Routing Designator: LLV, LLU, LLF, LLD

To Customer Routing Designator: BAW(Voice),LST (Fax), VQS(Modem), BAE (Failed Modem or Fax to Josy)

Data Classification: TS//SI//NF//RAG-F

Data Type: DNR (USSID 126, CSDF)

Authority: FBI FISA

Source System Digraph: RR, UA

Partner Controlled
 NSA Controlled

Site Processing

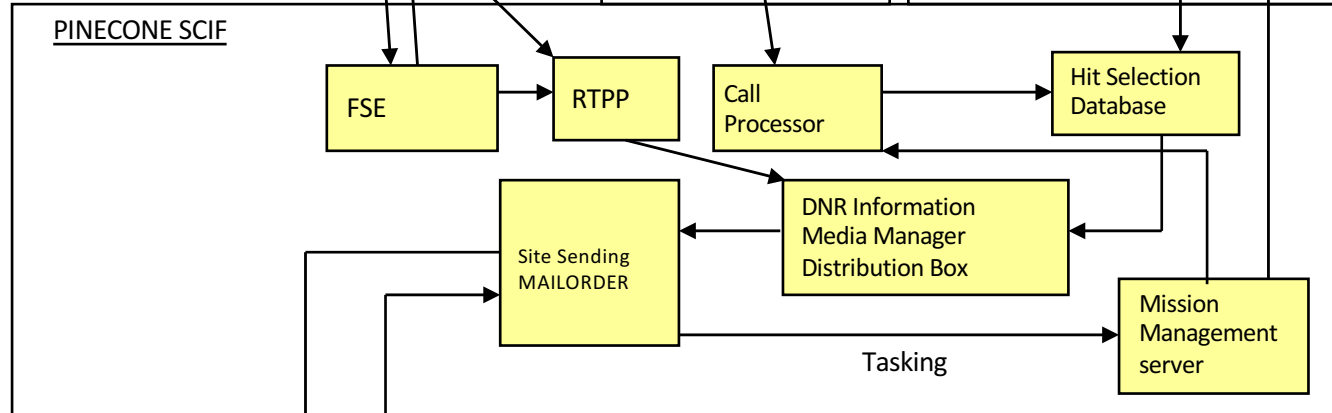

Corporate Processing - NSAW

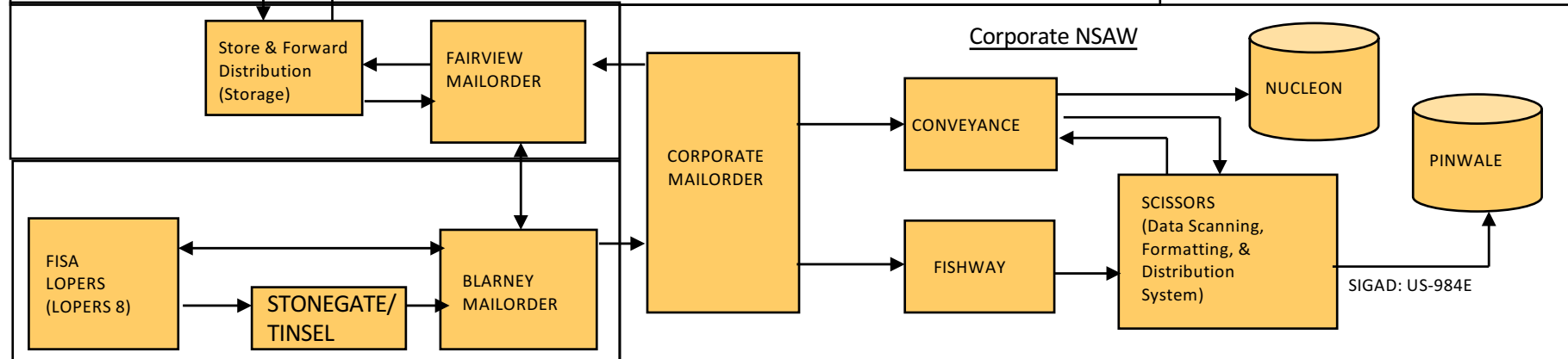

NSA FISA Voice/Fax/Modem DNR&VoIP

Access-Partner Processing

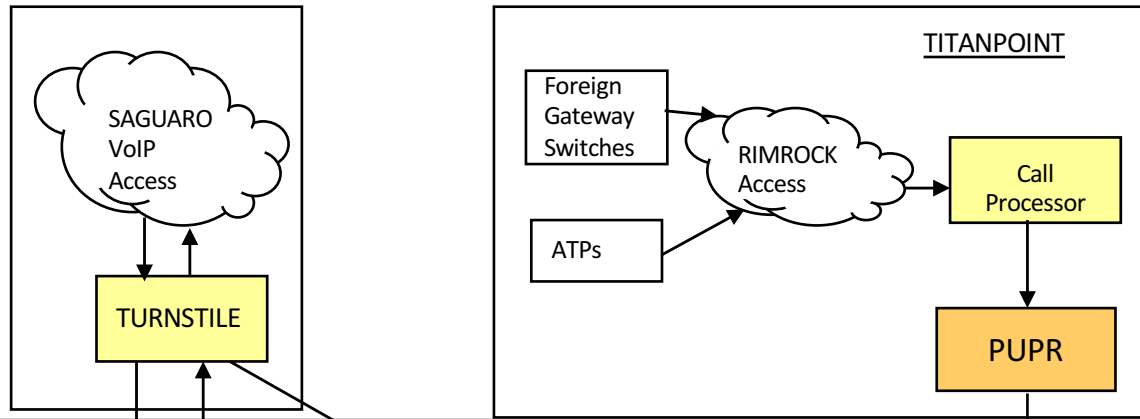

SIGAD: US-984E

PDDG: AX

CASE Root: SSO CASNs, XM* (change to BLARNEY CASN because of TDM conversion until LOPERS upgrade for file-based TND lookup)

To Customer Routing Designator: BAW, BAY(Voice), LST (Fax), VQF (Modem), BAE (Failed Modem or Fax to Josy)

Data Classification: TS//SI//NF//RAGTIME

Data Type: VoIP DNR

Authority: NSA FISA

Partner Controlled (Yellow)
NSA Controlled (Orange)

Site Processing

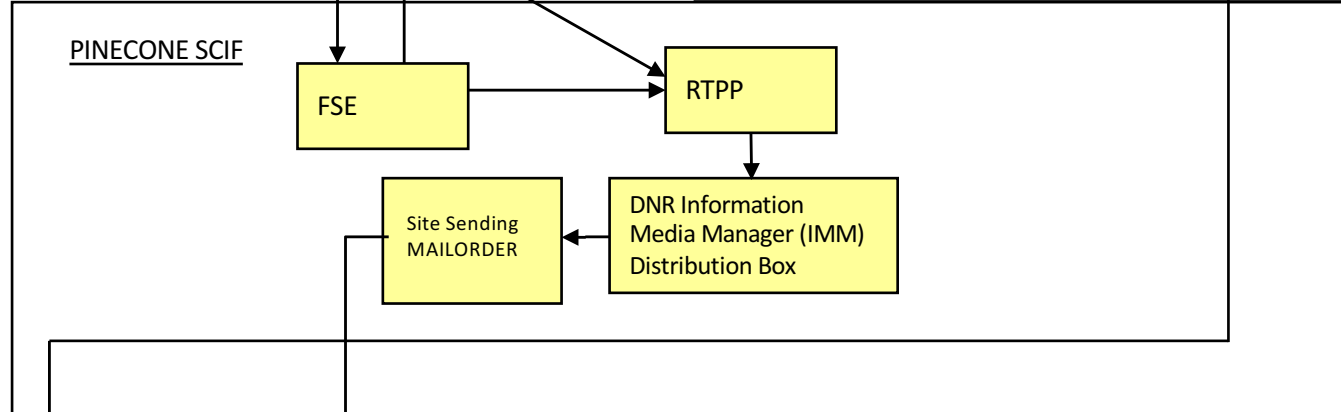

Corporate Processing - NSAW

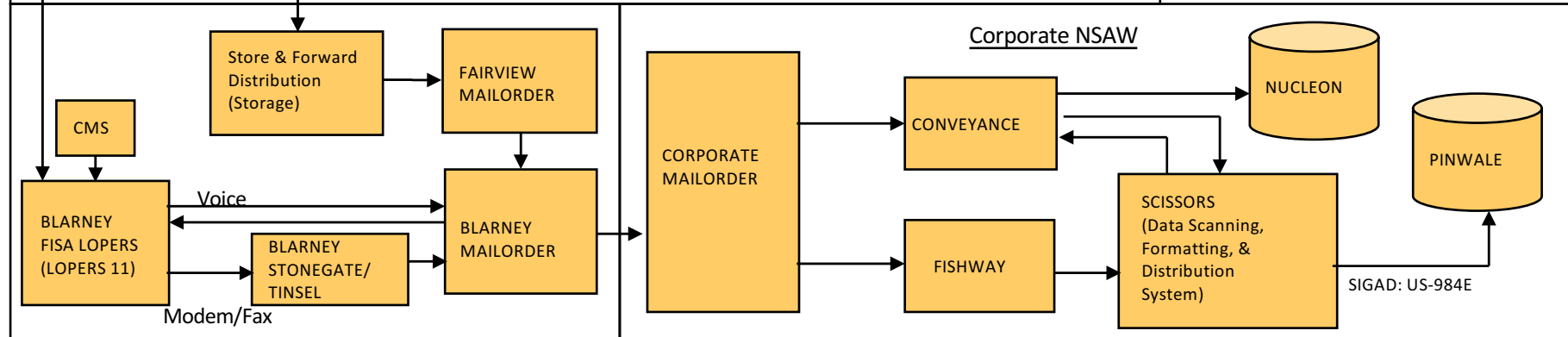

SIGAD: US-984E

Transit Voice/Fax/Modem DNR&VoIP – FAA 704/705b

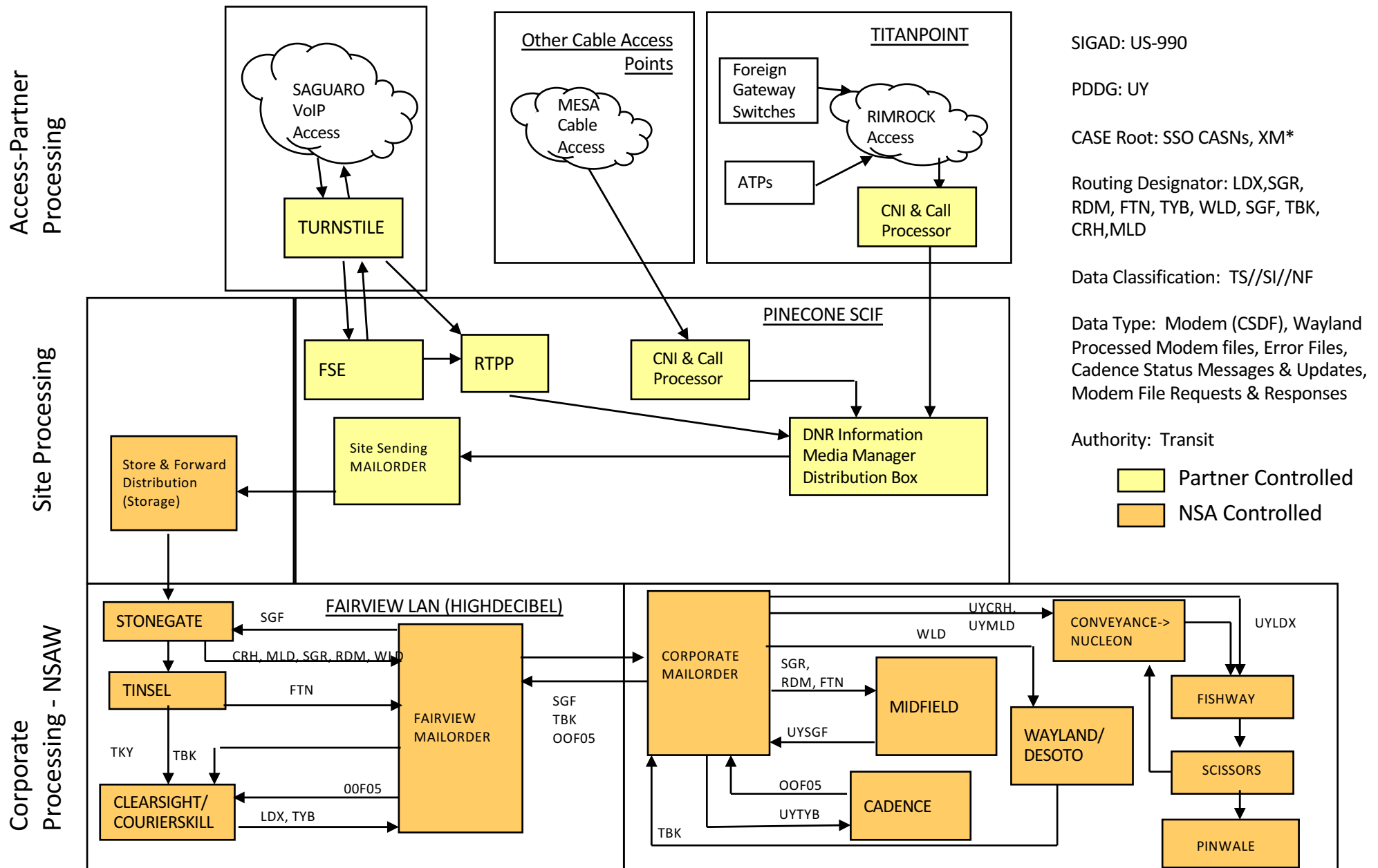

Transit DNI Content (BUGCATCHER)

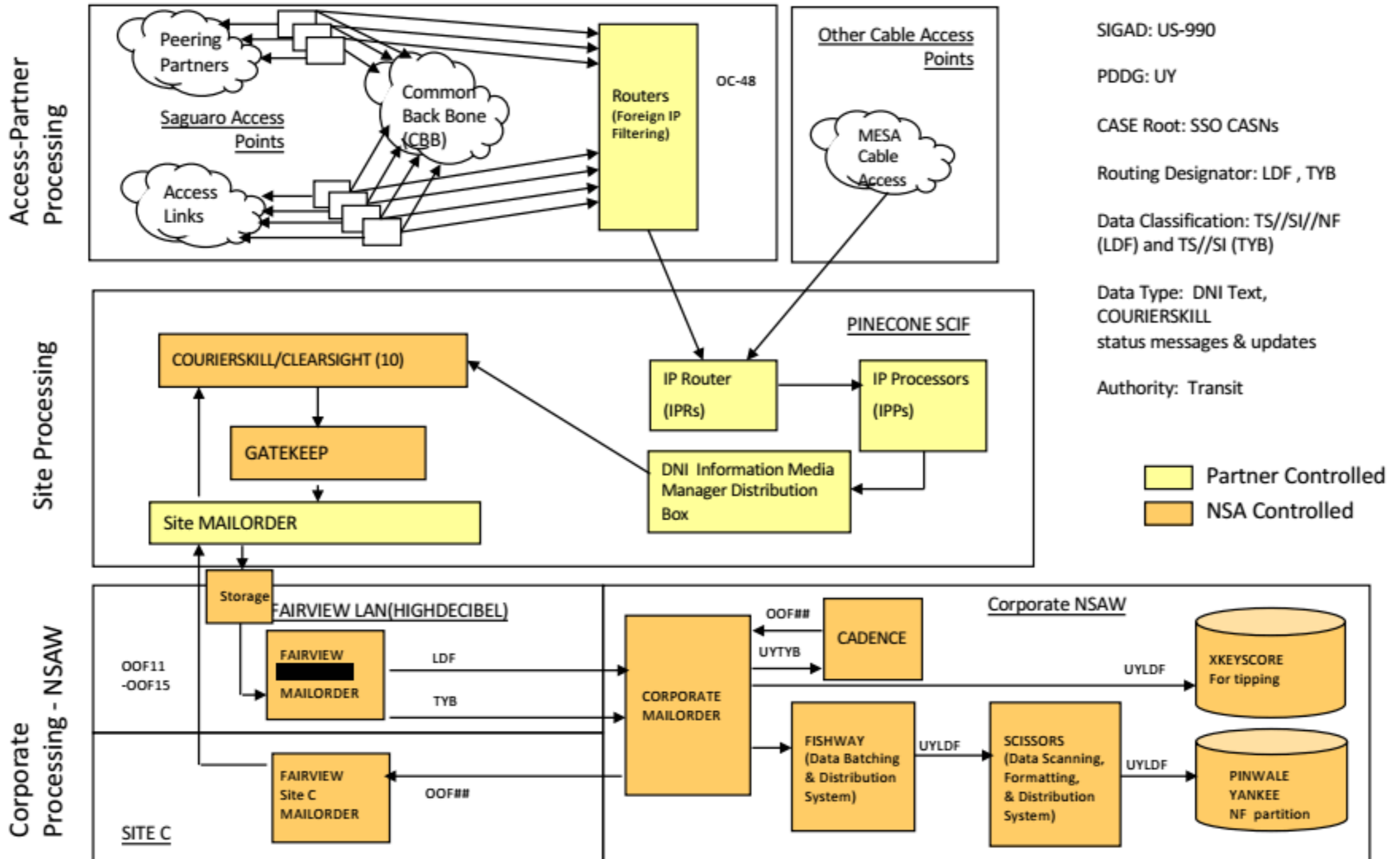

Transit DNI Metadata (IMDRs)

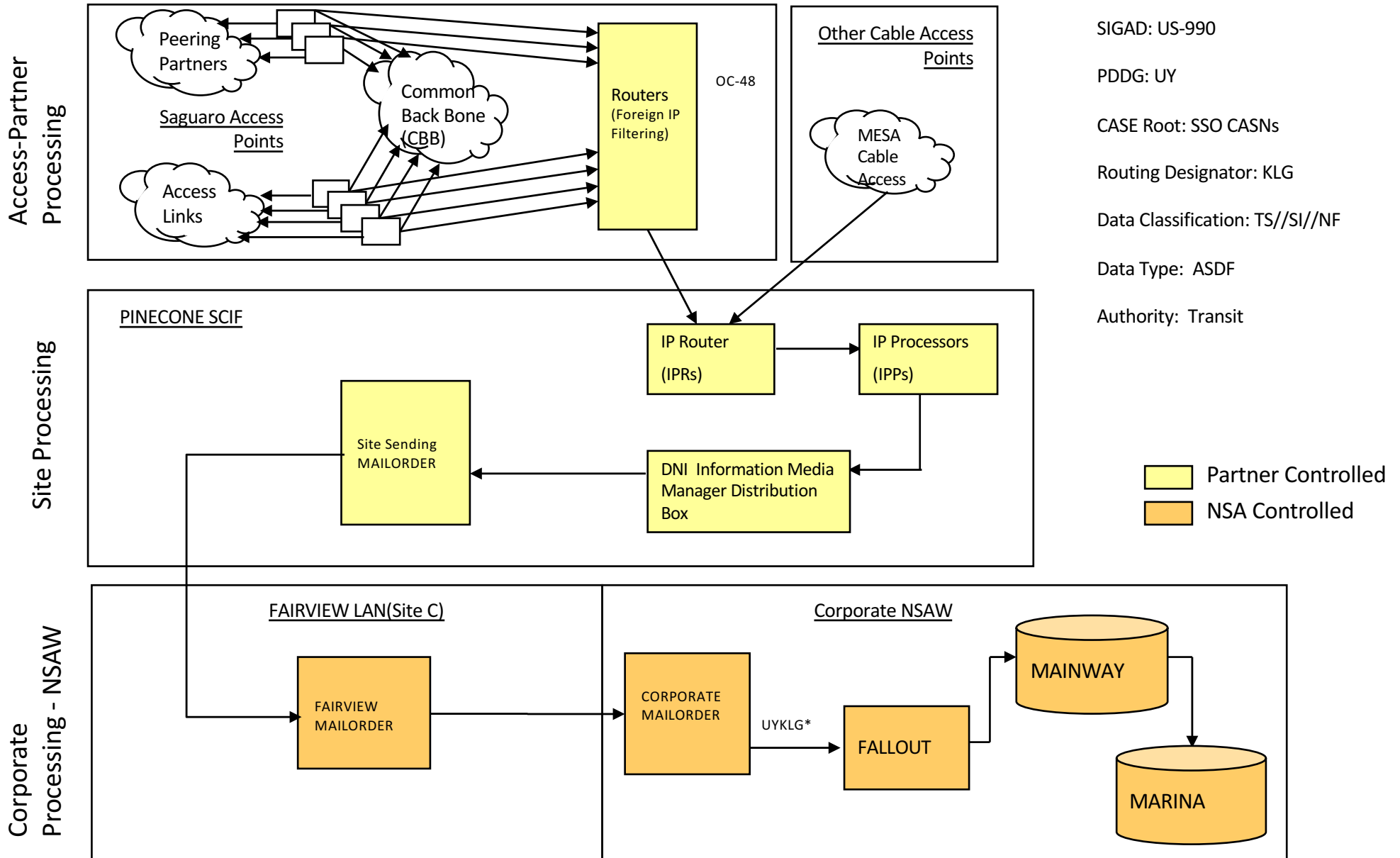

Transit DNR Metadata & SMS

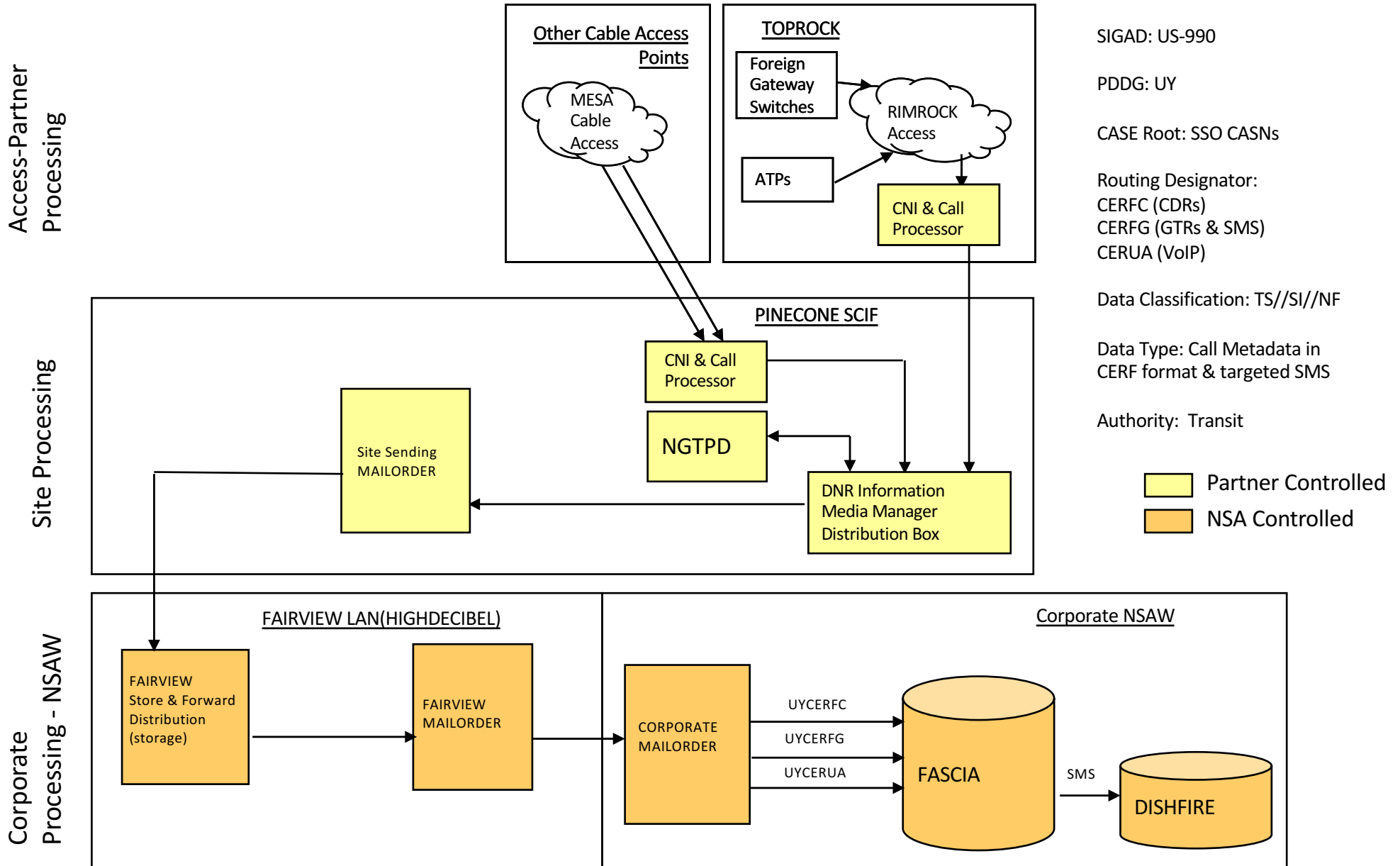

SIGAD: US-990

PDDG: UY

CASE Root: SSO CASNs

Routing Designator:
CERFC (CDRs)
CERFG (GTRs & SMS)
CERUA (VoIP)

Data Classification: TS//SI//NF

Data Type: Call Metadata in
CERF format & targeted SMS

Authority: Transit

Partner Controlled
NSA Controlled

Business Record FISA -SEAGULL Metadata Flow Sourced From Billing Records & ICDRs

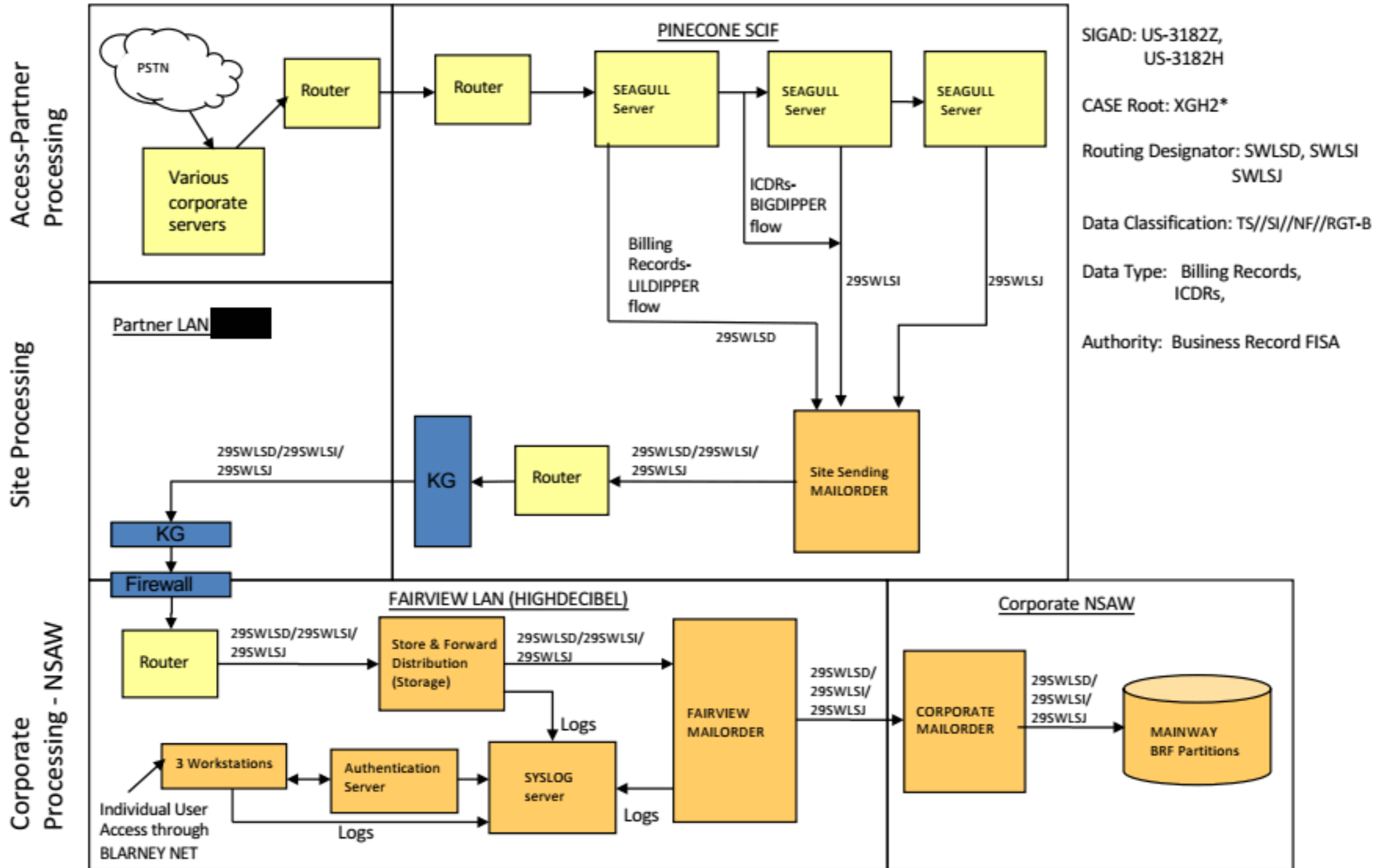

MOBILE-SEAGULL Metadata Flow Sourced From Billing Records

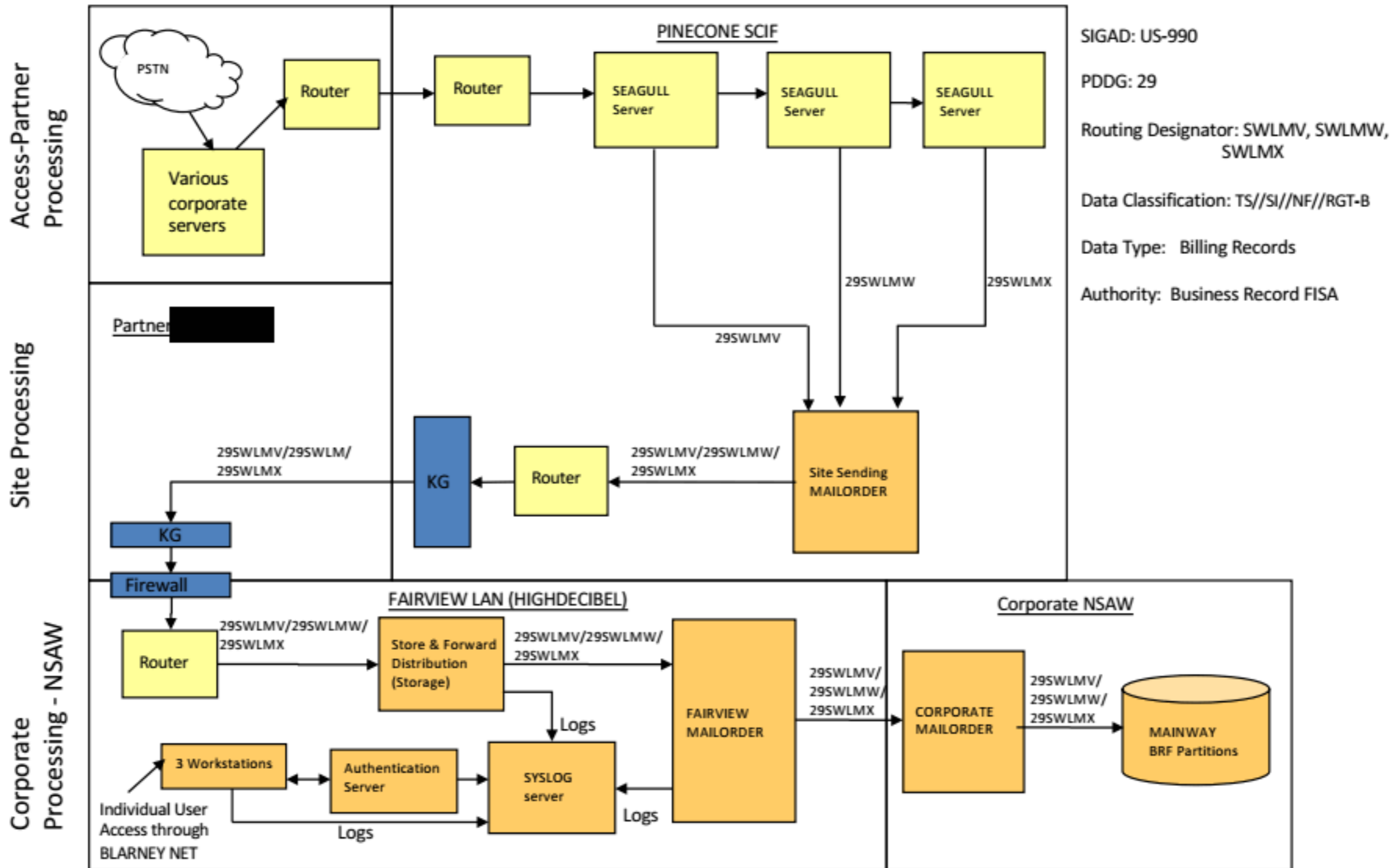

SIGAD: US-990

PDDG: 29

Routing Designator: SWLMV, SWLMW, SWLMX

Data Classification: TS//SI//NF//RGT-B

Data Type: Billing Records

Authority: Business Record FISA

ICDR Metadata flow (aka HAVASU)

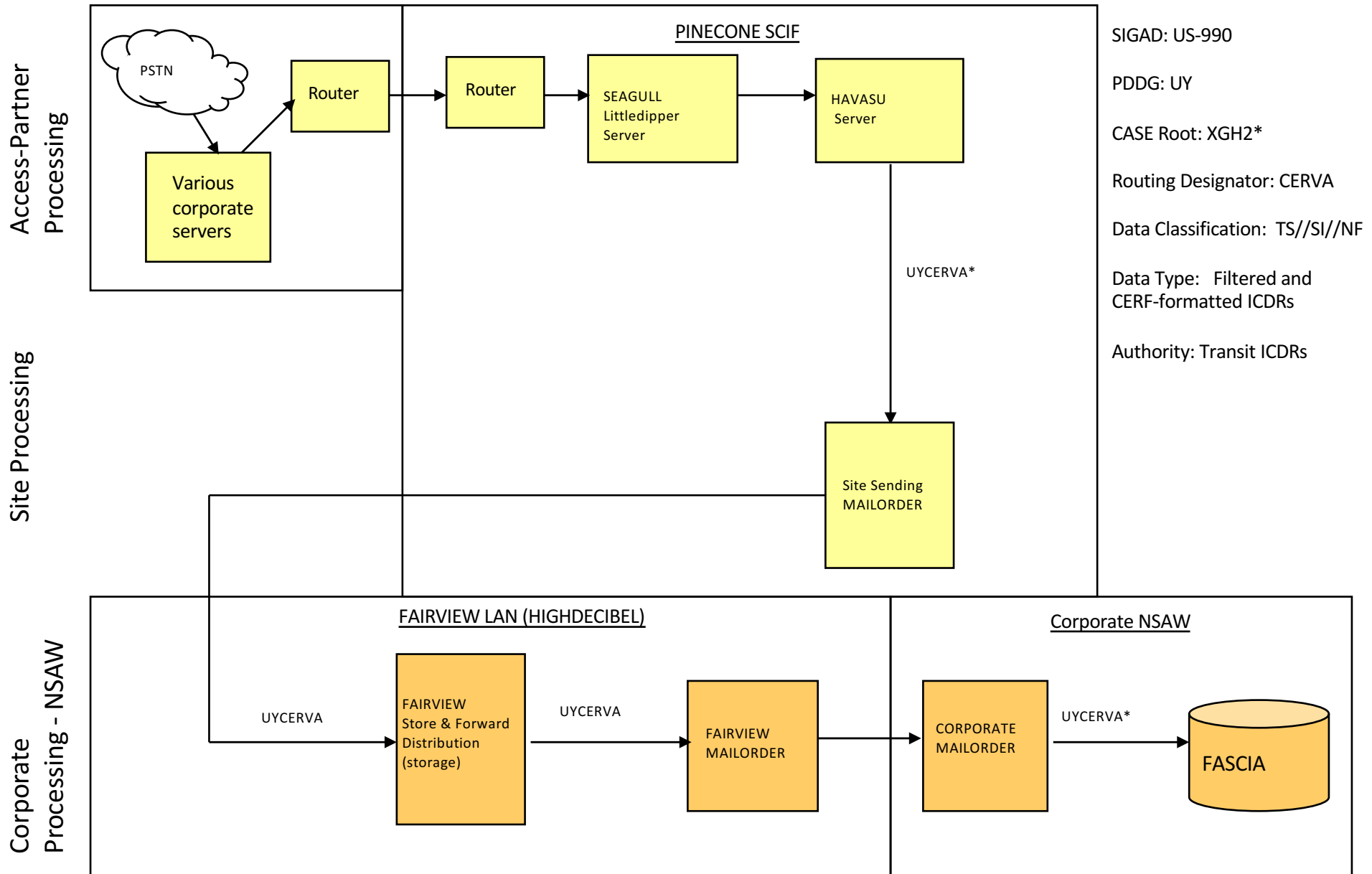

FAIRVIEW NSA FISA Email

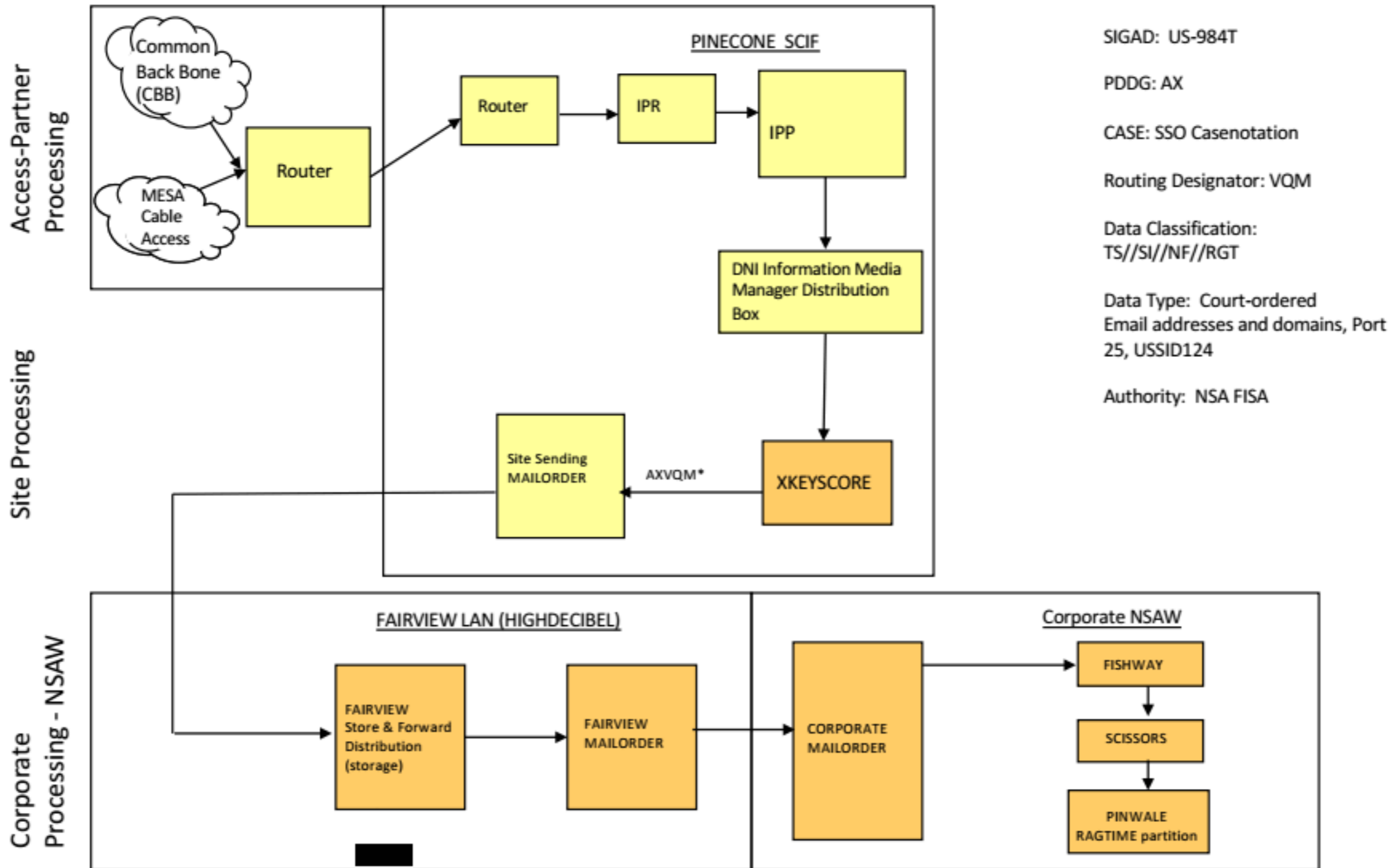

FAIRVIEW NSA FISA IP

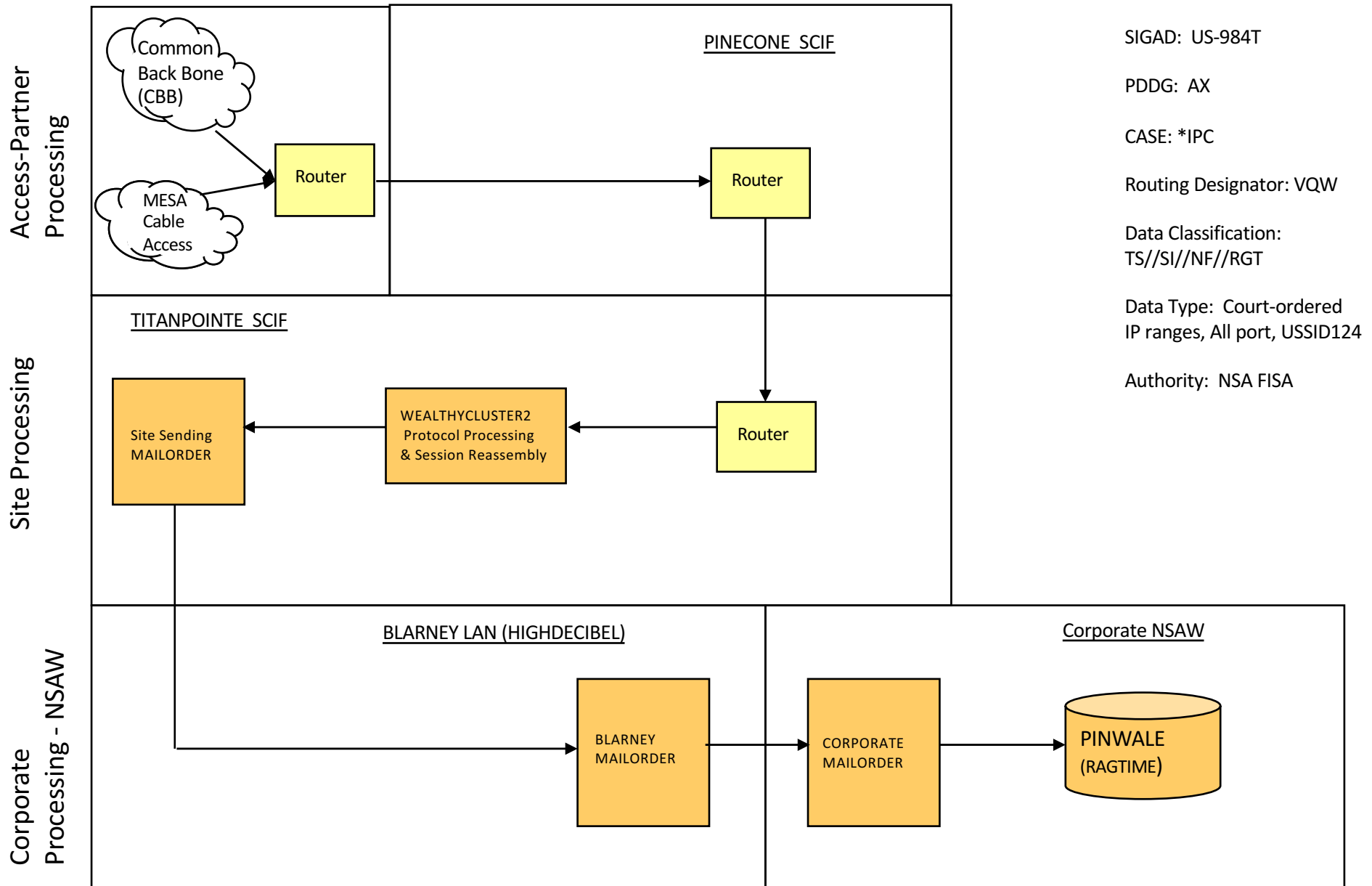

SIGAD: US-984T

PDDG: AX

CASE: *IPC

Routing Designator: VQW

Data Classification:
TS//SI//NF//RGT

Data Type: Court-ordered
IP ranges, All port, USSID124

Authority: NSA FISA

*** Currently Inactive ***

PR/TT XNET 1 DNI Metadata

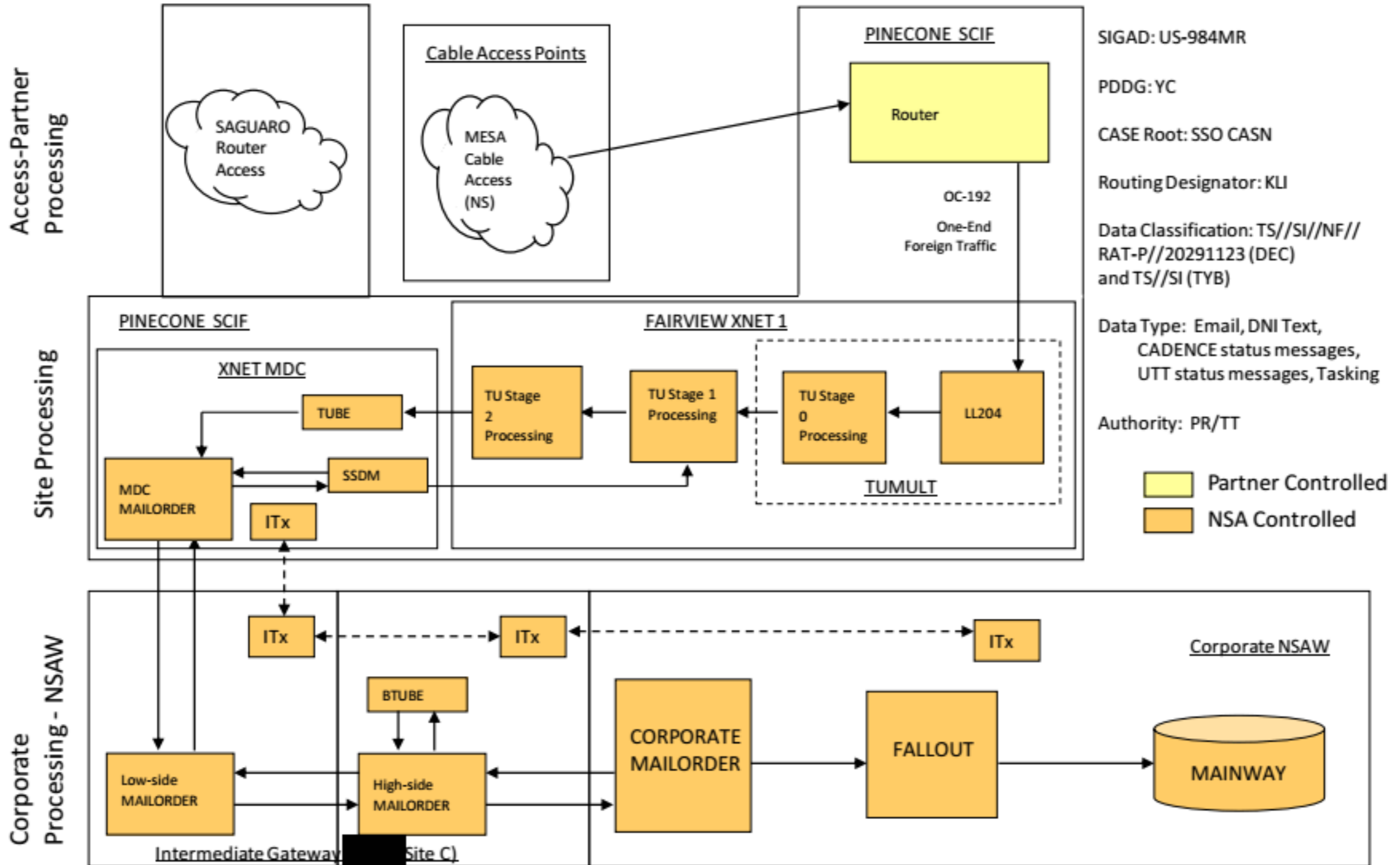

*** Currently Inactive ***

PR/TT XNET 2 DNI Metadata

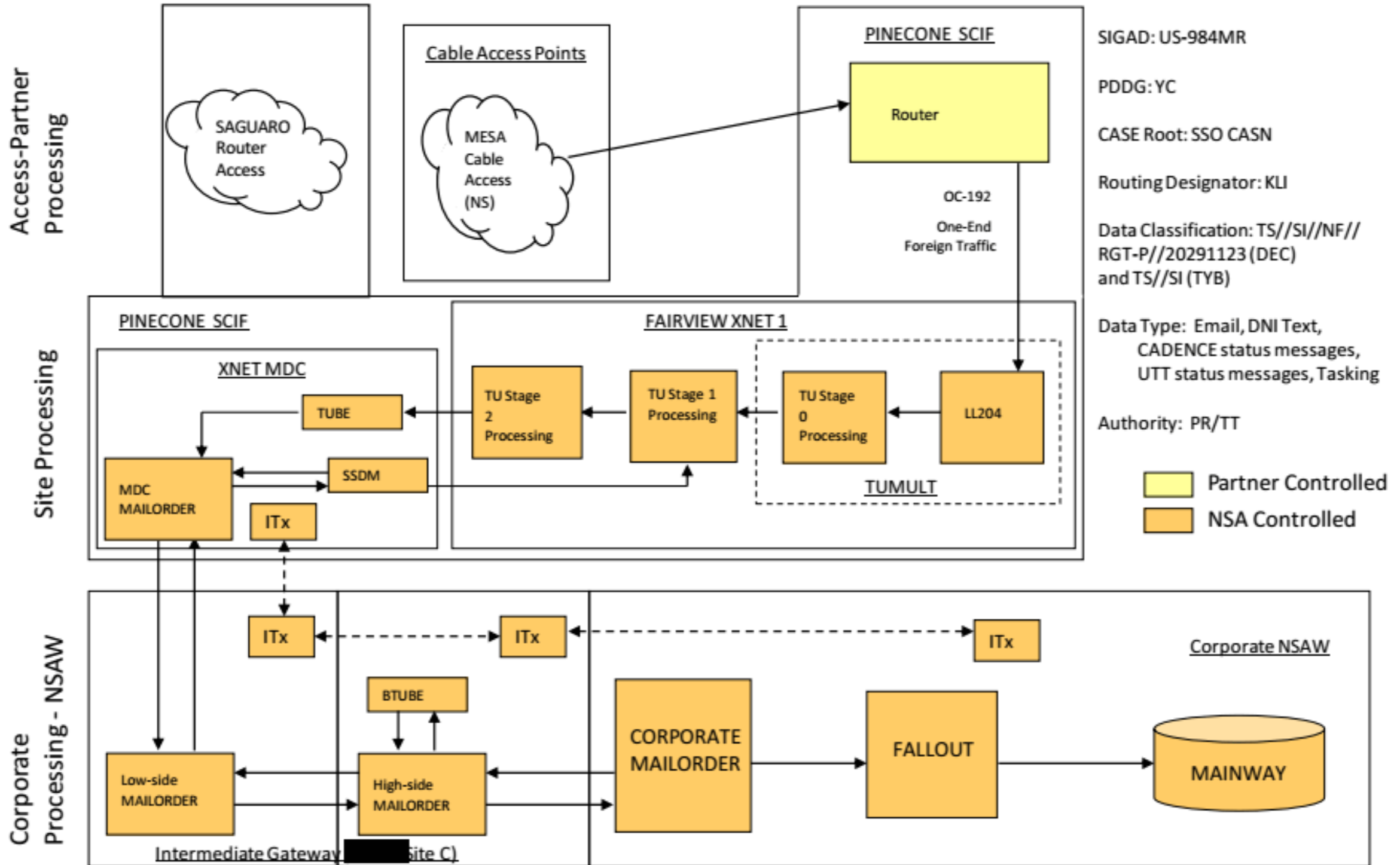

*** Currently Inactive ***

PR/TT XNET 3 DNI Metadata

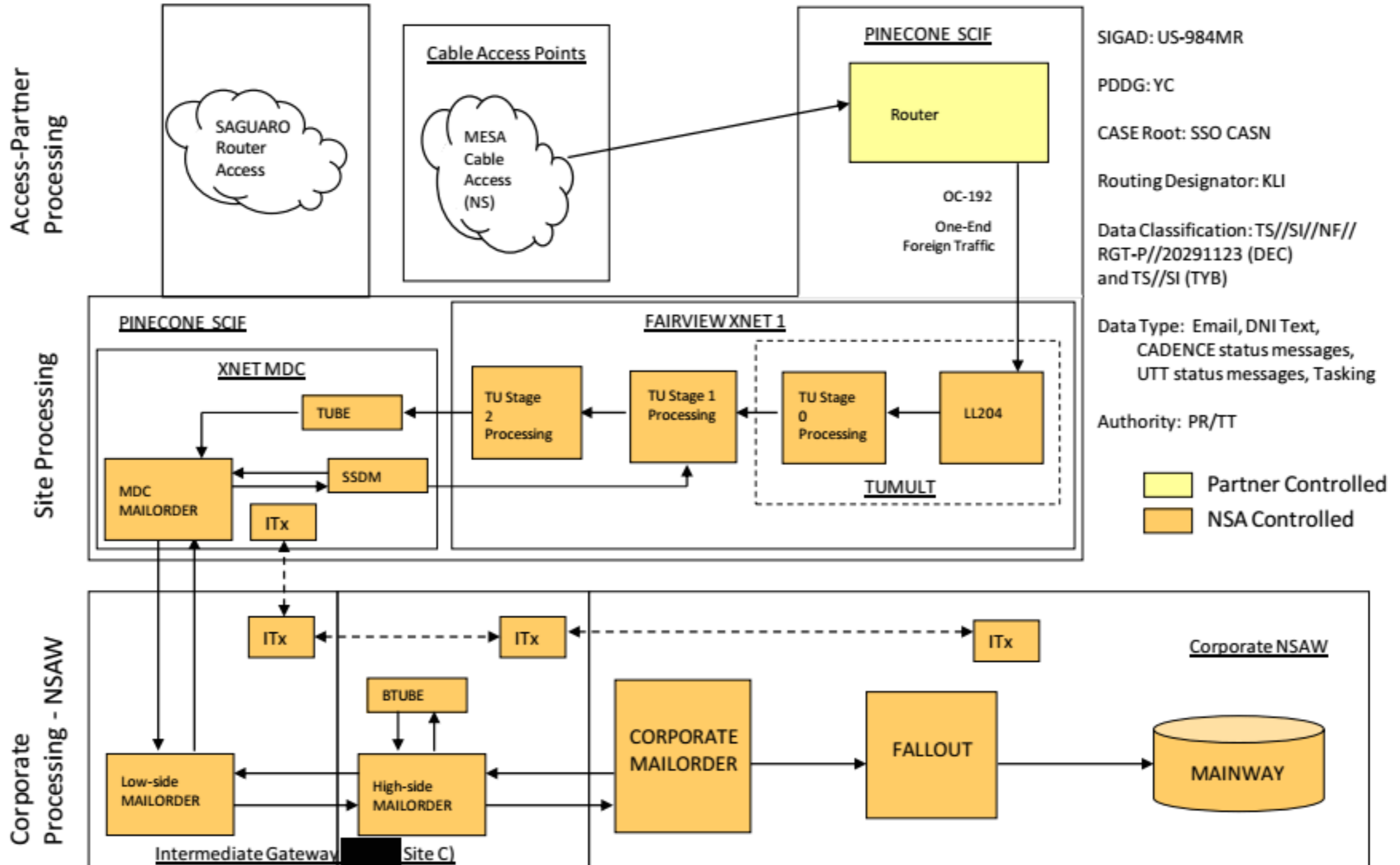

SIGAD: US-984MR

PDDG: YC

CASE Root: SSO CASN

Routing Designator: KLI

Data Classification: TS//SI//NF//RGT-P//20291123 (DEC) and TS//SI (TYB)

Data Type: Email, DNI Text, CADENCE status messages, UTT status messages, Tasking

Authority: PR/TT

Access-Partner Processing

Site Processing

Corporate Processing - NSA

TAO Implant

Shaping

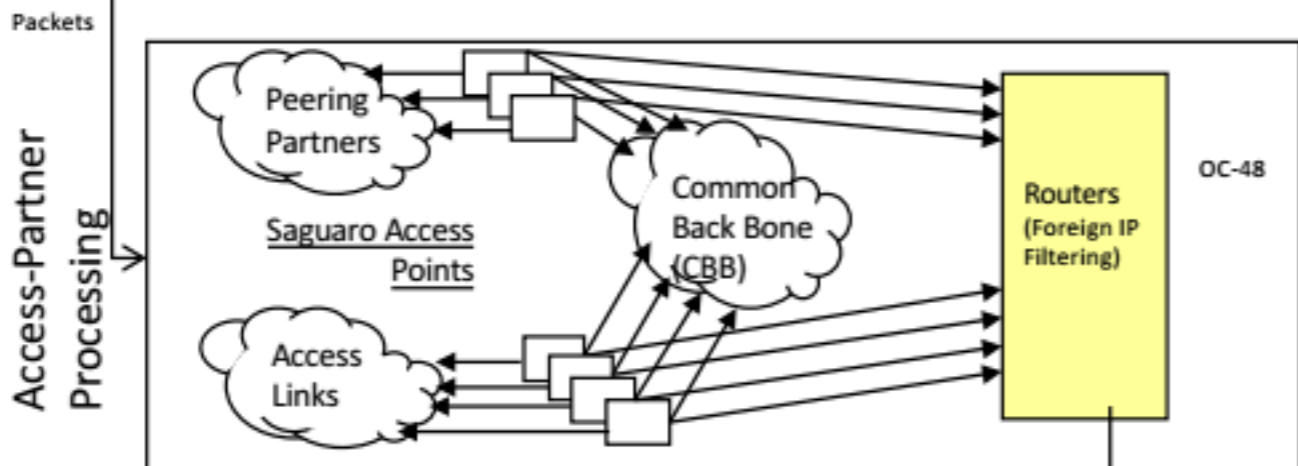

SIGAD: US-3105S1

PDDG: DU

CASE Root: Can be multiple, Currently just YM.*

Routing Designator: FV*, Right now just FVT for DARKTHUNDER

Data Classification: TS//SI//REL

Data Type: PCAP

Authority: E.O.12333

Partner Controlled
 NSA Controlled

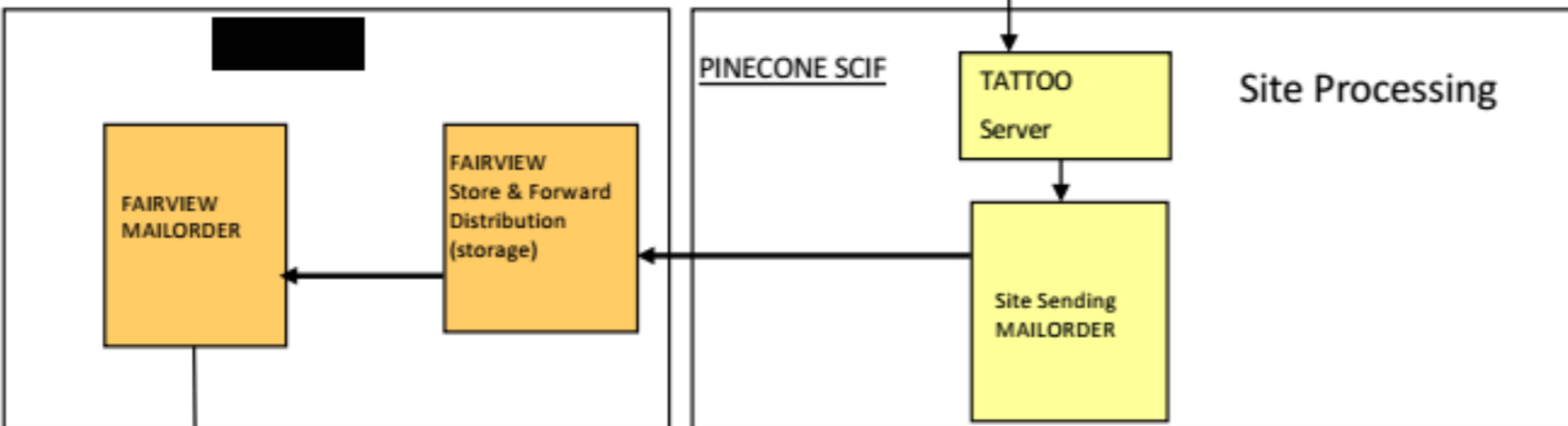

FAIRVIEW LAN(HIGHDECIBEL)

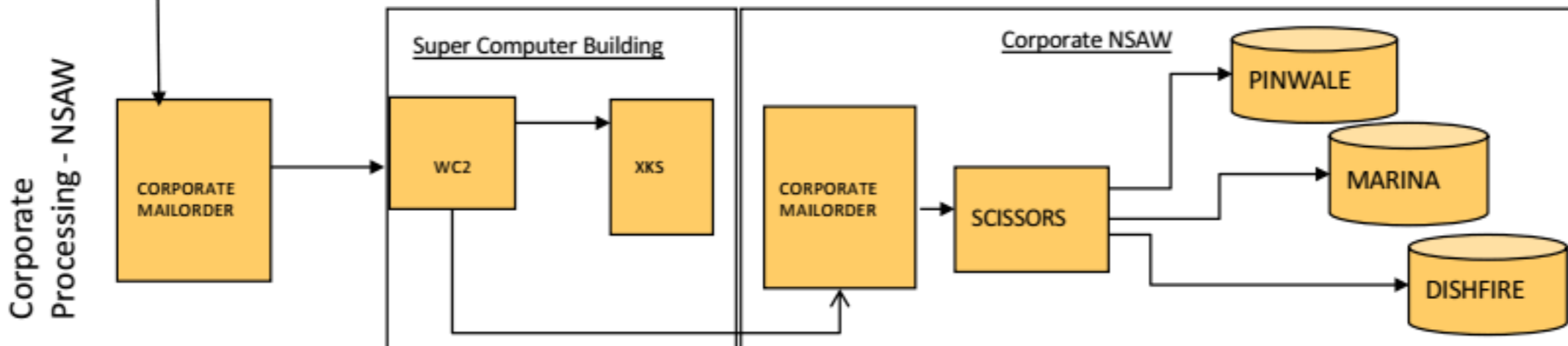

Shaping to vPCS

TAO Implant

Packets
Access-Partner
Processing

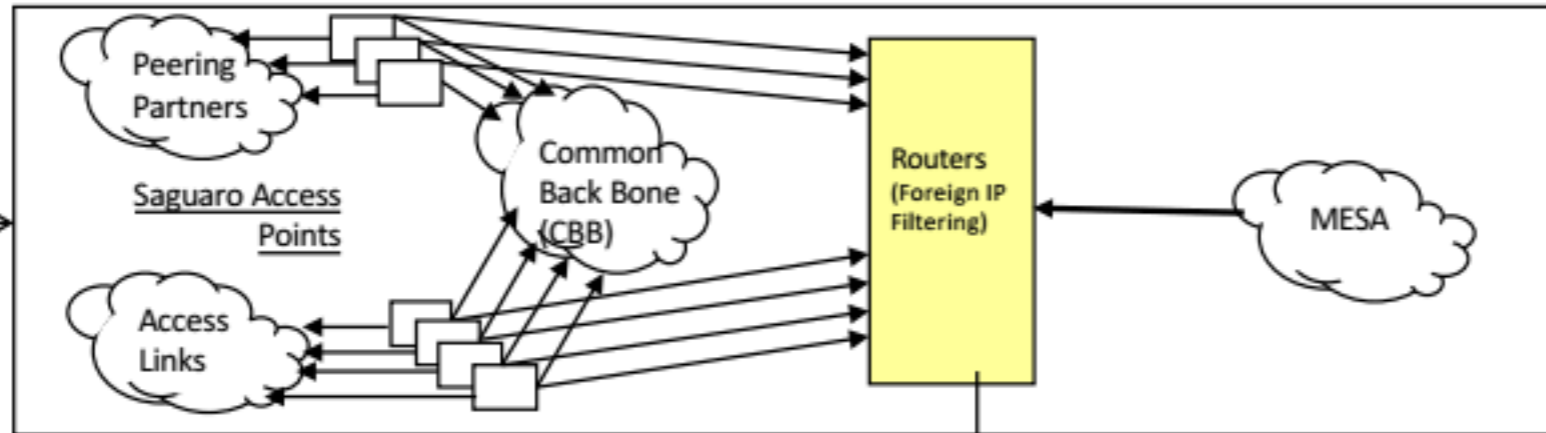

SIGAD: US-3105S1

PDDG: DU

CASE Root: Can be multiple, Currently just VE.*

STF trigraph for STEELFLAUTA
CMO trigraph for TURMOIL
Monitoring. I30 implant data flow metrics.

Data Classification: TS//SI//REL

Data Type: PCAP input to vPCS

Authority: E.O.12333

Partner Controlled
 NSA Controlled

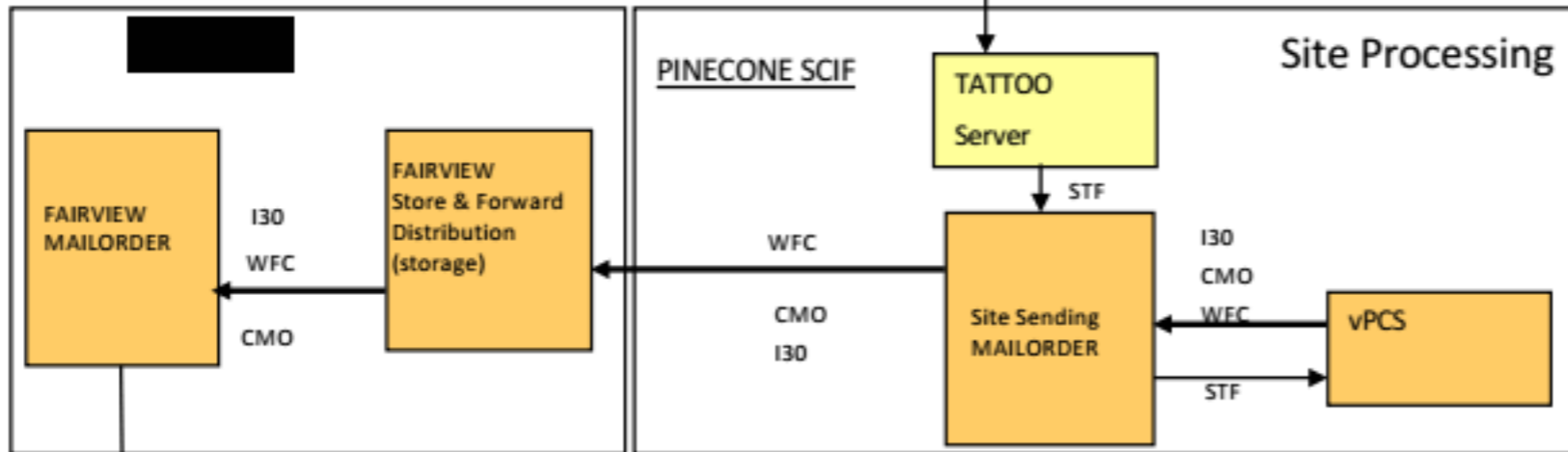

Corporate
Processing - NSAW

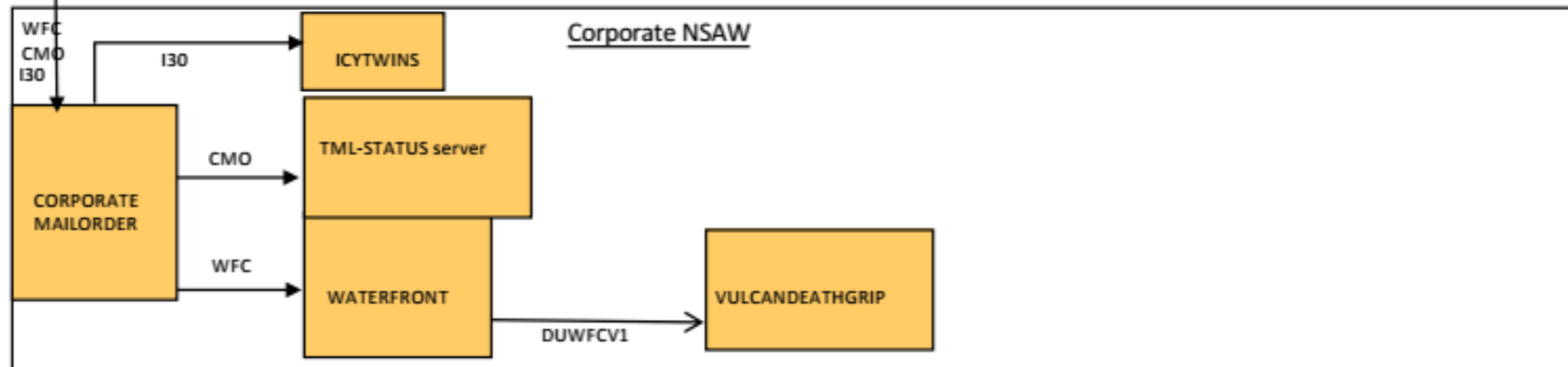

UNITY FAA (Voice/Fax/Modem) DNR&VoIP

Access-Partner Processing

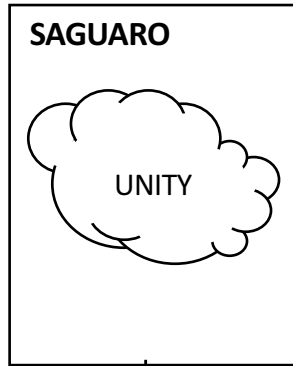

SIGAD: US-984X2

PDDG: 29

CASE Root: **TBD**

To BL Routing Designator: FLV, FLU, FLF, FLD

Source System Digraph: L1, L2

To Customer Routing Designator:
BAV(Voice),LST (Fax), VFG (Modem), BAE (Failed Modem or Fax to Josy)

Data Classification: TS//SI//NF//RGT-A

Data Type: DNR (USSID 126, CSDF)

Authority: FAA

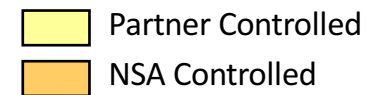

Site Processing

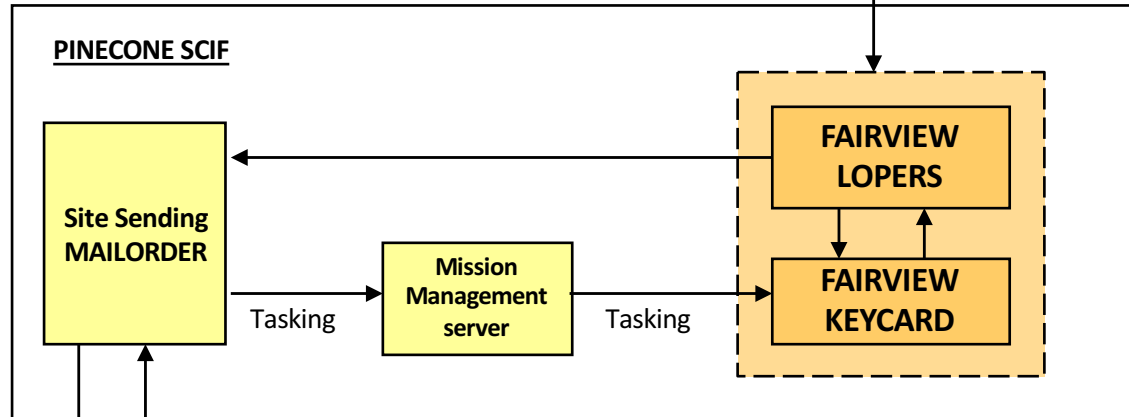

Corporate Processing - NSAW

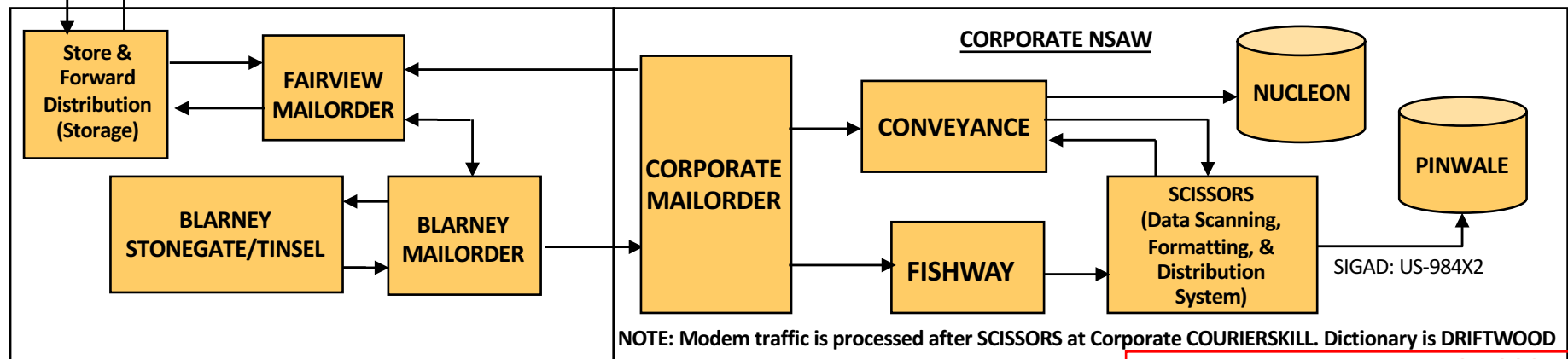

Derived From: NSA/CSSM 1-52

Dated: 20070108

Declassify On: 20361101

FAIRVIEW TDY Handbook

(U) A guide for traveling to Site

Last Updated: 6 February 2013
POC: 

Derived From: NSA/CSSM 1-52
Dated: 20070108
Declassify On: 20301121

(U) The purpose of this TDY Handbook is to provide the Fairview traveler with the proper procedures and guidelines when traveling on official business, either local, CONUS or OCONUS, in support of the Fairview Program. This information is applicable to all Fairview team members who travel or have the potential to travel.

(U) General Authority:

Locally:

(U) Governed by SSO Office and Program Travel Policy and Processes.

In Country:

(U//FOUO) As directed by the Program Director or delegate (Mission Program Manager).

(U) SSO Required Courses:

(U) In accordance with SSO Travel Training Requirements for Conferences, CONUS and OCONUS TDYs.

(U) Official Travel (CONUS)

(U) Conferences:

- CIAT2101 – Elicitation Techniques (8)
- Check-in w/SSO Security (Travel Alias)

(U) Mission Travel:

- OHES1108 – Heartsaver (4)
- SOST2209 – Basic Sensitive Ops (40)
- CIAT2101 – Elicitation Techniques (8)
- Check-in w/SSO Security (Travel Alias)
- Check-in w/Mission Program Manager

(U) Official Travel (OCONUS)

(U) Mission Travel:

- OHES1108 – Heartsaver (4)
- SOST2209 – Basic Sensitive Ops (40)
- SOST2213 – Surveillance Detection Orientation (40)
- CIAT2101 – Elicitation Techniques (8)
- CIAT2103 – Personal Security & Safety Overseas
- Check-in w/SSO Security (Travel Alias)
- Check-in w/Mission Program Manager
- Security Awareness Travel Briefing (call [REDACTED] to schedule)
- Medical Center Clearance (schedule appointment)

(U) Program Recommended Courses:

(U) None

(U//FOUO) Cover Travel:

(U) Cover travel information is provided merely as an FYI. FAIRVIEW does not have any sites that require cover travel.

(C) Defense Management Support Services Activity (DMSSA) – required cover, as traveler is not to overtly identify himself/herself as an employee of the National Security Agency or a member of the intelligence community. Traveler must attend a cover briefing from S353 (Special Operations) once a year, or prior to the TDY. Please note: If special arrangements need to be made please email dl ssotravel. Each situation will be considered as needed.

(U) Helpful Links for country information / TDY documents:

- NSA: Ft. Meade
NSAnet (go travel)
[REDACTED]
- U.S. Department of State:
NSAnet: [REDACTED]
Internet: <http://www.state.gov>
- U.S. Department of State travel page:
[REDACTED]

(U//FOUO) Partner Organizations - Visits to Partner Meeting Facilities:

(C) Locations include: EAGLE, EDEN and TITANPOINT (SSB)

Dress: Depends on meeting type (standard: business casual).

No NSA Badges or NSA Insignia Apparel.

Do not use DoD identification, use Driver's License for identification (where applicable).

- When entering facility:
Sign In at Front Desk with:
 - Name: Self
 - POC: Meeting POC
- When entering SCIF:
Follow instructions per visit/meeting POC.

Notes:

EAGLE – For visitors without retention picture badges -- please return temporary badge (provided at front security desk) at the end of each visit.

EDEN/TITANPOINT (SSB) – Contact [REDACTED] ([REDACTED])
([REDACTED]) or [REDACTED] ([REDACTED]) prior to traveling. [REDACTED]
[REDACTED] and/or [REDACTED] will be responsible for contacting the FAIRVIEW
Partner (Lithium) Security POC and Bureau Security POC to coordinate the security-
related details of the visit. Traveler will be contacted by [REDACTED] or
[REDACTED] with specific OPSEC instructions. Please also coordinate visit with Partner

POC (person visiting, or person coordinating the meeting), Partner PMO ([REDACTED]) and Deputy Program Director ([REDACTED])

(U) Sites: Visits to FAIRVIEW Collection and/or Processing Facilities:

(C) Visits to FAIRVIEW collection sites are not allowed. All requests need to be coordinated and approved by FAIRVIEW Program Management – [REDACTED] or [REDACTED]. For visits to PINECONE, contact – Contact [REDACTED] ([REDACTED]) or [REDACTED] ([REDACTED]) prior to traveling. [REDACTED] and/or [REDACTED] will be responsible for contacting Lithium Security POC and Bureau Security POC to coordinate the security-related details of the visit. Traveler will be contacted by [REDACTED] or [REDACTED] with specific OPSEC instructions.

Coordinating with the Partner:

- Provide at least 1 week's notice (if possible) prior to visit.
- Coordinate with the following personnel:
 - 1) Visit POC (person meeting w/at site, or person coordinating the visit)
 - 2) [REDACTED] – Program Management Office

(U) Cover Stories:

(C) When traveling to the Partner's facilities (EAGLE, EDEN, PINECONE) or other program sites (TITANPOINTE), family members and co-workers (who are not cleared), can be given generic travel plans, to include general geographic area visiting (i.e., City, State) and general purpose for visit (i.e., attend technical meeting, install equipment, site visit). Provide family members and/or co-workers with cell phone number, pager number, hotel phone number and any other applicable unclassified phone numbers. Also provide your family with a co-worker's phone number (one not on TDY with you) in case of an emergency at home. Your family should then contact the co-worker, who in-turn will contact you at the Partner's facility. Provide the same co-worker with an itinerary so they will know when/where to reach you.

(U) Cover Vehicles:

(S) The BLARNEY program has several vehicles available for use when visiting sites that require U.S. Government anonymity. The sign-out sheet and keys are available from both [REDACTED] on the 2nd floor of the [REDACTED] Building in room [REDACTED] and in the file cabinet outside the BLARNEY Program Director office ([REDACTED] Building, room [REDACTED])

(U) The following guidelines are provided for travelers using the BLARNEY cover vehicles. Please read and understand them prior to using the vehicles.

GUIDE TO THE USE OF BLARNEY "COVER" VEHICLES

Revised: August 2006

Prepared by: DF5243, [REDACTED] (Revised 22 August 2006)

S328 Security Officer, [REDACTED]

Derived From: NSA/CSS
Declassify On: 20291123

INTRODUCTION:

(S//SI) The information provided below provides details on specific security concerns related to the use of the BLARNEY Cover Vehicles. These vehicles are for "Official Use Only" to include the transport of NSA personnel and equipment. These vehicles are solely for the use by personnel who actively support NSA/FBI Programs. These Programs currently include: BLARNEY, FAIRVIEW, STORMBREW and OAKSTAR.

ACCIDENT AND DAMAGE REPORTING

(S//SI) In the case of an accident, contact the police and request an accident report. Identify yourself as a DoD employee UNLESS reporting your identity could compromise an operation or site, (i.e., involved in an accident while pulling out of a site parking lot). If your address is requested, indicate Ft. Meade, Maryland ONLY. As soon as possible, contact [REDACTED] Security, [REDACTED] who in turn will contact the General Counsel's Office and the Federal Bureau of Investigation.

(U) Obtain identities and insurance information of all parties involved and obtain the names of witnesses. Within 24 hours of the accident you must complete Accident form SF91 and submit it to [REDACTED] Security.

(S//SI) In the event of an accident that COULD compromise an operation or site, use your personal identification (including your personal insurance information) when requested and notify [REDACTED] Security AS SOON AS POSSIBLE. Arrangements will be made, through the FBI, to contact all parties to provide correct and accurate information.

ACQUISITION AND ASSIGNMENT OF "COVER" VEHICLES

(S//SI) The BLARNEY "cover" vehicles are leased through the Washington Field Office of the FBI in response to our specific vehicle requirements. The lease is through a commercial cover company. However, some personnel are aware of the FBI link but have no knowledge of NSA's involvement. No one should EVER have contact with the leasing company.

BREAKDOWN (on-road failure)

(U//FOUO) All vehicles should be covered under manufacturer's warranty for major mechanical problems. If necessary, call a tow truck and have it towed to the closest dealer. Failures, such as flat tires, dead battery, should be treated as non-warranty repair and may require the operator to pay out of pocket with

reimbursement provided from BLARNEY's "cash" account as long as a receipt is provided.

(S//SI) When the vehicle is taken to a dealer for repair, use your personal identification but provide your Division Anonymity outside phone number. ETS Division Office: [REDACTED]

CLEANING VEHICLES

(U) A credit card, provided by the [REDACTED] Security Office, should be used when taking the Cover Vehicles to the Car Wash. (See "Credit Cards")

COMMERCIAL DRIVER'S LICENSES

(U) DoD civilian employees who operate vehicles having a gross vehicle weight rating (GVWR) or combined GVWR of 26,001 or more pounds on public highways must have a Commercial Driver's License (CDL).

CONTRACTOR USE OF GOVs

(S//SI) Contractor personnel are prohibited from operating the "Cover" Vehicles.

COURSE ATTENDANCE

(S//SI) Vehicles may be used to attend Agency-sponsored/off-campus courses if attendance is required in a "cover" capacity. Operations always take priority over any other vehicle use.

CREDIT CARDS

(S//SI) [REDACTED] Security is issued a limited number of cover credit cards for use for vehicle maintenance. The FBI controls these cards and does not want them used in the local area for gasoline purchases. The cards may be used when taking a vehicle TDY or for small repairs (i.e., tires, battery). Always sign your true name to the receipt. Turn the receipt over to the [REDACTED] Security Team as soon as possible.

DISPATCHING ASSIGNED VEHICLES

(U//FOUO) The sign out log for the BLARNEY cover vehicles is located with the keys. You can reserve a vehicle by signing up on the calendar online at "go calendar," choose either BLARNEY Silver or Blue van calendar. Each time a vehicle is taken, you must complete the Sign-Out Log. Operational use of the vehicles takes priority over any/all other requirements. Return the keys and/or vehicle passes to the sign out location.

DISPOSING OF VEHICLES

(U//FOUO) The [REDACTED] Security Team handles the disposition of the vehicles.

EMISSIONS INSPECTIONS

(S//SI) The FBI notifies [REDACTED] Security when emission inspections are due. Volunteers are solicited from ETS, and funds obtained from the BLARNEY

"cash" account, to get the emissions inspections completed. ALWAYS ENSURE THAT THE PROPER TAGS ARE ON THE VEHICLES BEFORE GOING FOR EMISSIONS TESTING.

FINES, TRAFFIC VIOLATIONS

(U) Fines and Traffic Violations are the responsibility of the individual.

FUEL TYPES

(U) Fuel type should adhere to the guidelines provided by the auto manufacturer.

IMPAIRED DRIVING

(U) Drivers are responsible to determine and report if he/she is physically incapable of operating an Agency vehicle. Employees may be considered negligent for accidents determined to be caused by their sleepiness, use of medications, alcohol, etc.

INSURANCE

(S//SI) The Government is self-insured, via the Tort-Claims Act. Claims will be handled by the FBI or U.S. Army, Ft. Meade, depending upon the type of claim. Personal injuries to NSA employees are covered under the Workmen's Compensation Act.

KEYS

(U//FOUO) Keys to the BLARNEY vehicles are located with [REDACTED] on the 2nd floor of the [REDACTED] Building in room [REDACTED] and in the file cabinet outside the BLARNEY Program Director office ([REDACTED] Building, room [REDACTED])

LAWS, COMPLIANCE WITH

(U) Operators of any NSA vehicle shall comply with all applicable Federal, State, local laws and no employee may be directed or compelled to disregard these laws.

MAINTENANCE

(U//FOUO) The BLARNEY Car Custodian is responsible for the routine maintenance of the vehicles, according to the manufacturer's recommendations.

MEALS AND PERSONAL STOPS

(S//SI) Stops, should they be necessary, shall occur only along the most direct route. In addition, for appearance reasons, stops shall always be avoided within 10 miles of any NSA facility. Vehicle operators shall not schedule their local travel itinerary to include stopping for lunch at the beginning or end of their trip (i.e., early checkout). In addition, NSA vehicles (to include "cover" vehicles) shall NOT be used to transport employees to non-official luncheons (if individuals pay for their own lunch, it's not official). Employees (with the exception of those on TDY who have a need to stop at places required for personal upkeep, comfort or health) shall never use government vehicles to accomplish personal business (e.g., pick up dry cleaning, haircuts, etc).

(S//SI) ****EXCEPTION:** In keeping with OPSEC purposes (i.e., FBI recommends following an indirect route between NSA and Covert sites), the most direct route may be improper. This is at the discretion of the operator and based on guidelines provided by the FBI or the ██████████ Security Office.

OFFICIAL USE OF NSA "COVER" VEHICLES

(S//SI) The operation of all NSA vehicles is restricted to "official uses" only. Official uses are those which are necessary to accomplish the Agency's mission when operating under a "cover" capacity. Employees are subject to strict penalties when they operate vehicles for other than official uses.

(S//SI) Normally, the answer to what constitutes official use is a matter of management discretion, to be exercised within applicable laws and regulations. Supervisors should ensure that all vehicles under their control are being used solely in direct support of the NSA mission. Before requesting or using NSA vehicles, the following questions must be asked:

1. Is the use of the vehicle for official business and in the best interest to the Government?
2. Have other means of completing the task been ruled out (i.e., telephone, fax, mail)?
3. Is the official business being performed in a "cover" capacity?

(U//FOUO) Personnel using cover vehicles, with business at covert facilities, should avoid direct routes to and from NSA. Good security practices should be employed when determining the route. While there are rules involving overt government vehicles requiring the use of the most direct route between locations, they do not apply to cover vehicles. However, this should not be construed as permitting the use of the vehicle for personal business or other improper activities.

(U//FOUO) Some activities which are not normally considered official use of Government vehicles are: stopping by any employee's home; personal errands; going to pick up food, coffee mess goods, or travel to luncheons; transporting supplies to organizational picnics; and sightseeing. With the exception of parking in conjunction with official business, Agency vehicles should not, as a general rule, stop in NSA employee parking areas (i.e.; to transfer items, retrieve personal goods or coffee mess items).

OPERATION OF VEHICLES

(U) Agency motor vehicles will be used in such a way as to maximize fuel economy and to extend the life of the vehicle.

PARKING OR GARAGING OF VEHICLES

(S//SI) When not in use, the "Cover Vehicles" should be parked outside of [REDACTED]. When returning the keys remember to indicate the location of where the vehicle is parked.

(U) To minimize the chance of theft or tampering, all vehicles will be secured when parked. This includes shutting off the engine, setting the parking brake, closing all windows, and locking the door.

PASSES TO ENTER NSA SECURE AREA ENTRANCES

(S//SI) This does NOT refer to parking passes but rather entry to NSA loading dock areas. These passes are maintained by the ETS Division and issued on an as needed basis. It is permissible to take the cover vehicles through the Canine Road Inspection Station for one-day compound passes.

PENALTIES FOR MISUSE

(U//FOUO) Penalties for unauthorized or willful misuse of an NSA motor vehicle shall be cause for disciplinary actions as follows:

- **Civilian Personnel:** Any officer or employee of the Government who willfully uses or authorizes the use of any U.S. Government-owned or -leased passenger motor vehicle except for official purposes as authorized by 31 USC 1344 (b), or otherwise violates section 1344 shall be suspended from duty by the Head of the DoD Component concerned, without compensation, for not less than one month and shall be suspended for a longer period or summarily removed from office if circumstances warrant (31 USC 1349(b)). Other administrative actions, as warranted by the offense, shall apply if the misuse is determined not be of a willful nature.

REFUELING GUIDELINES

(U//FOUO) Each vehicle should contain NO LESS THAN one-half tank of gas. It is the responsibility of the driver to ensure that the vehicle is NOT returned with less than ½ tank. [REDACTED] has several gas cards for refueling use that can be signed out and are to be returned with the receipt for gas purchase.

REPLACEMENT CRITERIA

(U//FOUO) The [REDACTED] Security Office coordinates replacement vehicles with the BLARNEY Program Director and the Chief, ETS.

TAGS (Gov't & Non-Gov't)

(S//SI) Most cover vehicles keep the tag of the vehicle leasing company. Others have Maryland registration listed to the U.S. Government. Operators should be aware of which tags are on the vehicle they operate.

TOLL TICKETS

(U//FOUO) EZ Passes are included in the vehicles to cover the cost of tolls.

TOWING

(S//SI) If the vehicle needs to be towed, it must be towed to the nearest dealership. Cost of towing will be reimbursed (receipt required). If you are carrying classified or sensitive documents, contact the ETS Division [REDACTED] during work hours or, during off-hours contact SOCC, [REDACTED] to have someone meet you and pick up the material.

TRAINING, DRIVER'S

(S//SI) No additional training is required to operate a BLARNEY cover vehicle. A valid driver's license is required to operate these vehicles.

(U) Multicultural Awareness:

(S//SI) The FAIRVIEW program has one OCONUS site – SILVER COLLAM (SC). However, Multicultural Awareness is not a big factor in visiting this OCONUS site. When traveling to SC, the SSO employee will travel with a NSA Security representative, a Lithium Security representative, and a Bureau Security representative. The SSO employee should maintain a low profile, decline from venturing off on their own and always follow the guidance of the three program Security representatives.

(U) General information:

(U) None .

(U) Protocol:

(U) Clothing/Attire: Clothing/attire should be appropriate for the occasion and/or to blend in to the environment. Non-casual attire could cause an OPSEC red flag at certain sites. Check with visit/site POC for guidance on proper attire prior to traveling.

(U) Business Practices:

(U) Business atmosphere: Remain courteous to both Partners. Remember – this is a Partnership, not a Contractual Relationship.

(U) Conversational subjects: Always be aware of your audience. Remain cognizant of the clearance level of the person(s) you are speaking with or meeting with. Remember – never discuss other Partners with the FAIRVIEW Partner.

(U) Entertainment:

(U) Each individual Government traveler is responsible for his/her own entertainment expenses while traveling. When in doubt, refer to the following guidance on gifts)
([REDACTED] and ethics ([REDACTED]

(U) Passports:

(U) While the FAIRVIEW site SILVER COLLAM(SC) is considered a U.S. Territory and a passport is not required, it is recommended. Having a valid U.S. passport speeds up the check-in/check-out process at the airport. Additionally, it is better to have a valid

passport in case the plane has to be redirected to land in a nearby country that requires a U.S. passport. Only blue tourist passports should be used when traveling to SILVER COLLAM (SC).

(U) Passport information/guidance can be obtained at either of the following web pages:

- NSA intranet: Passport Services Team (LL22)
[REDACTED]
- Official Dept. of State Travel web page:
Travel.state.gov ([REDACTED])

(U) Courier Procedures:

(U) Each traveler wishing to courier classified material is required to view the Courier Briefing. This briefing can be viewed online at [REDACTED]. Once the briefing has been viewed, the traveler then requests a Courier Letter from the LL22 OPS Travel Office, however we only provide Courier Letters for the airlines. The travel coordinator verifies that the traveler has viewed the Courier Briefing and will then provide the Courier Letter to the traveler(s).

(U) Travel Planning and Planning Message:

(U) LL22 Corporate Travel Services (go travel) can assist with all aspects of official travel to include information on Government travel charge cards, reservations via [REDACTED] ([REDACTED]) official Government passports, Request for Travel Authorization (RTA) form, travel checklists, and much, much more!

(U) Mission Cost:

- **RTA's:** Form can be found at the following URL
[REDACTED]
- **Per-Diem (Food & Lodging):** Per-Diem Information can be found at the following URL [REDACTED]

(U) TDY Pre-Brief: ***All travelers need attend*******

(U) PMD – Deputy Program Director will coordinate this meeting. It should be held at least two weeks prior to TDY. Everyone directly supporting the system should be invited.

(U) TDY De-Briefs: ***Select travelers will attend briefing*******

(U) PMD – Deputy Program Director will coordinate this meeting. Selected travelers supporting the system should be invited.

(U) Post TDY Trip Report:

(U) Timeline and content as directed by Program Director or Deputy Program Director.



Low Speed DNI processing solution
Replacing WEALTHYCLUSTER2



Derived From: NSA/CSSM 1-52
Dated: 20070108
Declassify On: 20370101



SKIDROWE

- Components
- WEALTHYCLUSTER to TURNWEALTHY
- Capabilities of SKIDROWE by component

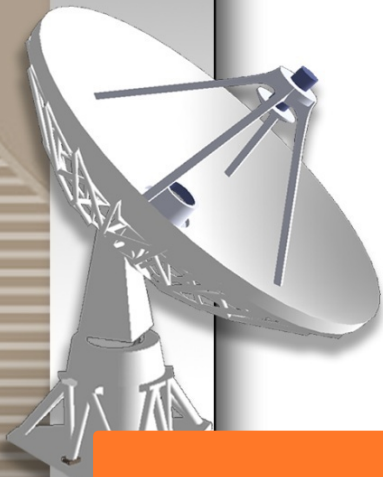



Components

- SKIDROWE is comprised of:
 - TURNWEALTHY
 - Signal Acquisition
 - vPCS
 - Real time packet exploitation
 - XKEYSCORE
 - Selection and Filtering

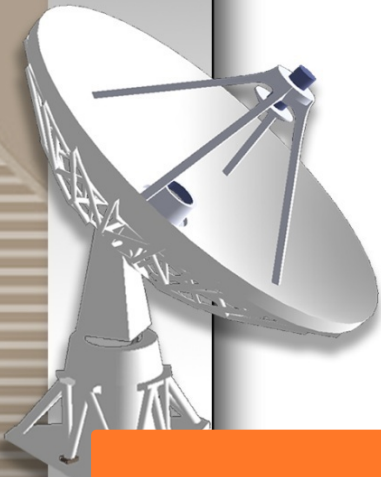



Functionality

- Allows 100% promotion of data for content selection and scanning
- GENESIS language fingerprint capability for XKS
- Real-time capabilities for cyber through VPCS
- Efficient: No duplication in processing functionality between vPCS and XKS





WEALTHYCLUSTER to TURNWEALTHY

(TS//SI//REL)

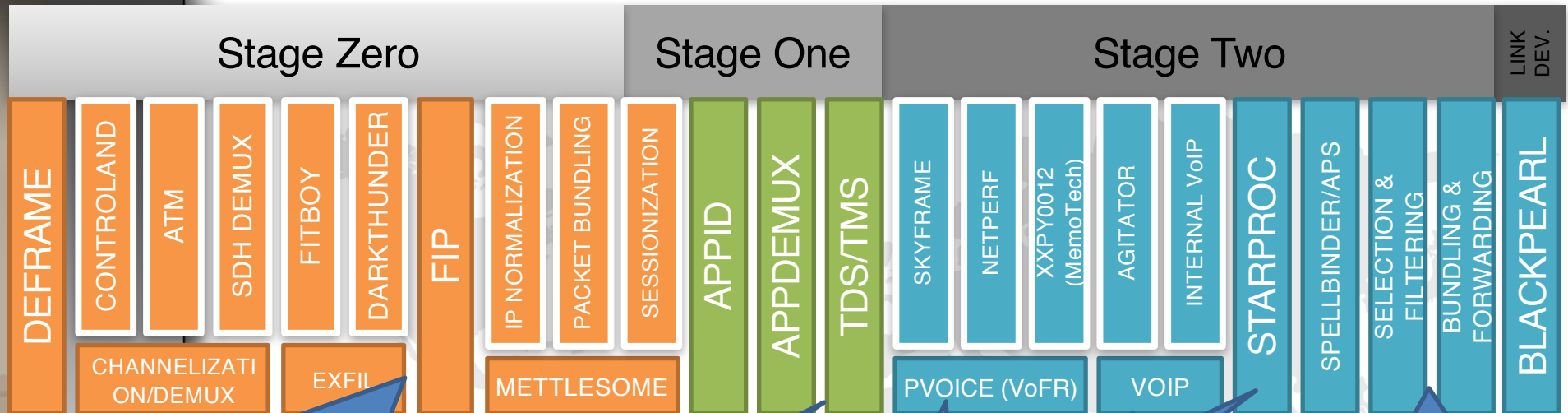

METTLESOME is essential for the ability of TURNWEALTHY to have multiple simultaneous outputs. FIP only produces sessionized output so the exfil capability must be removed.

With Stage 2 Phased Out, AppDemux, TDS and TMS are no longer utilized.

Application Layer Processors (StarProc) no longer delivered for WEALTHYCLUSTER.

The VoFR processing capabilities of PVOICE are not replicated elsewhere and will be maintained.

The Selection & Filtering, and Bundling & Forwarding capabilities are not used in TW.

VoIP Capabilities in WEALTHYCLUSTER are obsolete. FOPs are a more relevant solution.



WEALTHYCLUSTER to TURNWEALTHY

(TS//SI//REL)

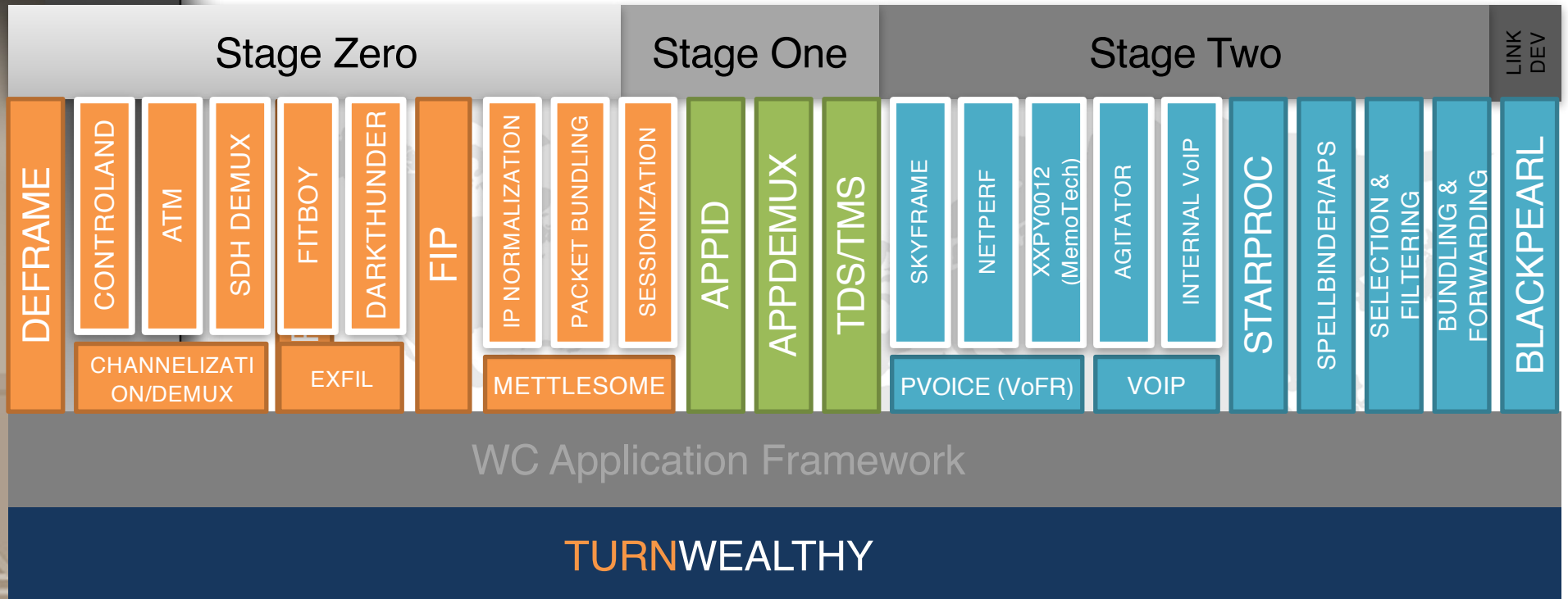



TURMOIL Capabilities

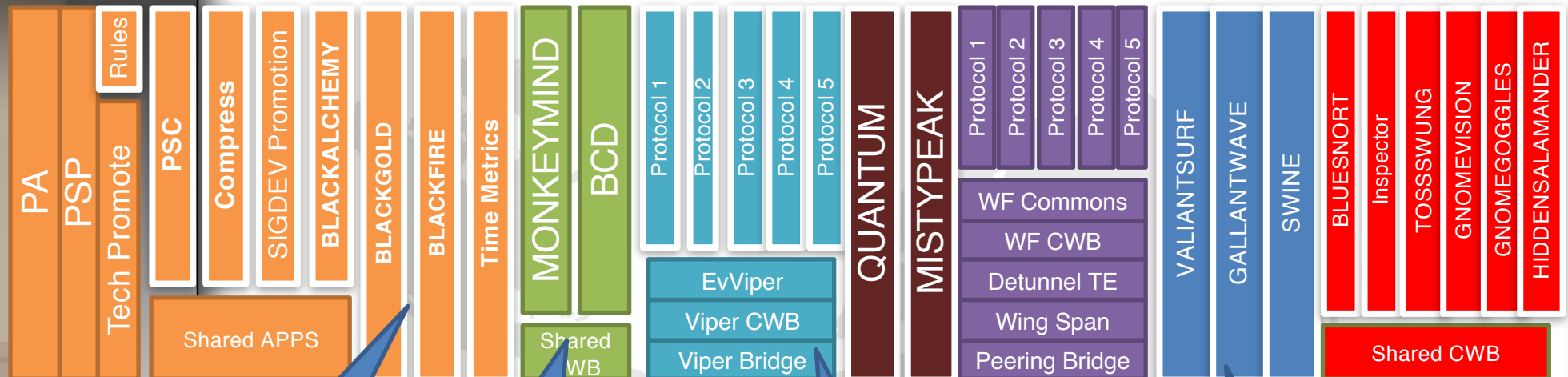

Metadata generation functionality is in XKEYSCORE

Strong Selection and BCD functionality is in XKEYSCORE

VOIP Processing will be done in XKEYSCORE

XKEYSCORE performs GALLANTWAVE decrypt



SKIDROWE

Lower Speed DNI Processing Solution

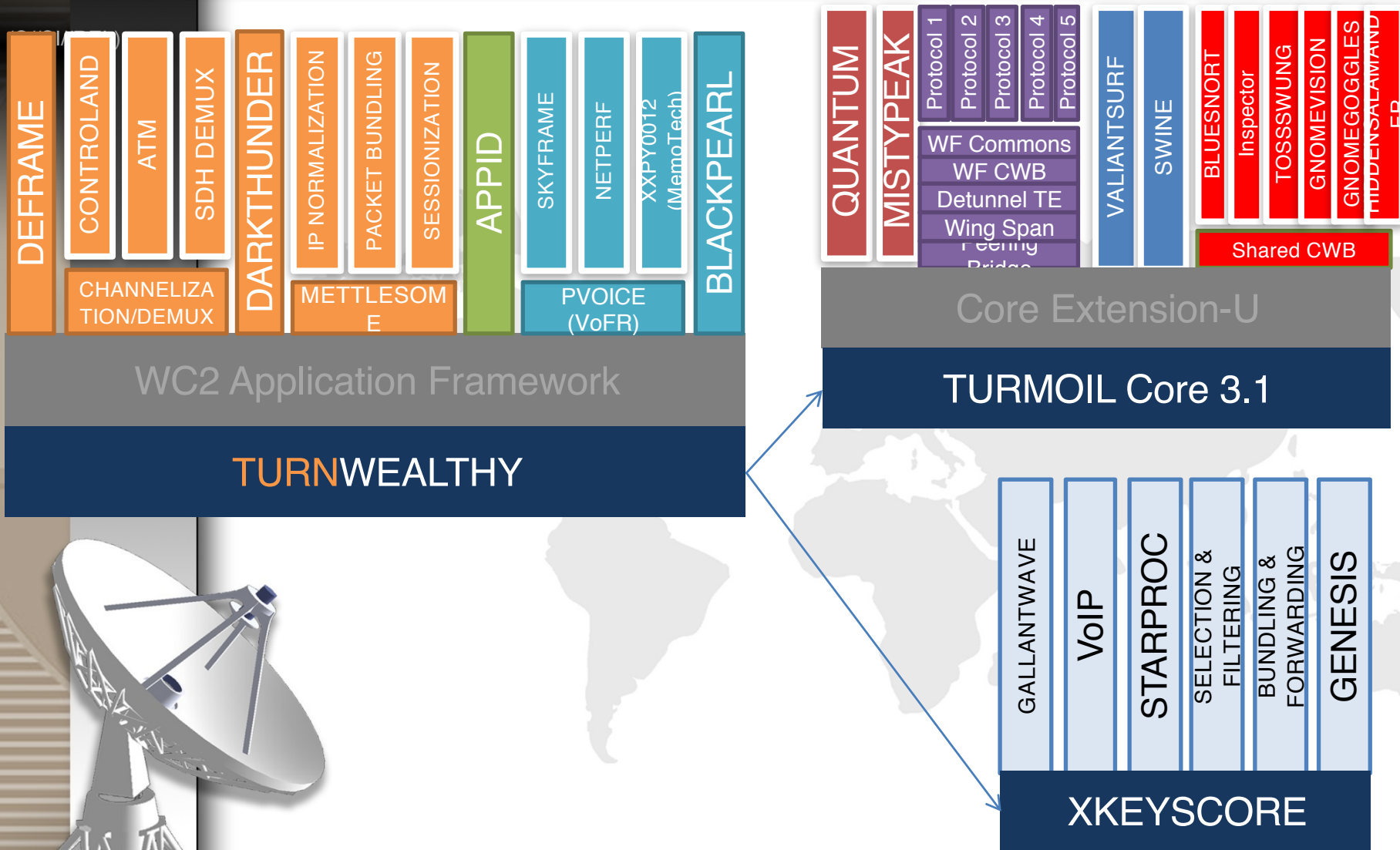



Special Source Operations

Corporate Partner Access

Briefed by: [REDACTED]

BLARNEY



STORMBREW

FAIRVIEW





TOP SECRET // COMINT // NOFORN//20291130



**Overall Briefing Classification Is
TOP SECRET//COMINT//NOFORN//X1**

TOP SECRET // COMINT // NOFORN//20291130



Relationships & Authorities

- Leverage unique key corporate partnerships to gain access to high-capacity international fiber-optic cables, switches and/or routers throughout the world
- Collection on U.S. soil is conducted under three different authorities:
 - Transit Authority: Collection of foreign intelligence communications which originate and terminate in foreign countries, but traverse U.S. territory
 - Foreign Intelligence Surveillance Act (FISA): Court ordered collection (NSA/FBI/FISA Court)
 - FISA Amendment Act of 2008 (FAA): Surveillance in the US when the target is reasonably believed to be foreign



BLARNEY AT A GLANCE

Why: Started in 1978 to provide FISA authorized access to communications of foreign establishments, agents of foreign powers, and terrorists

External Customers (Who)	Information Requirements (What)	Collection Access and Techniques (How)
Department of State	Counter Proliferation	DNI Strong Selectors
Central Intelligence Agency	Counter Terrorism	DNR Strong Selectors
United States UN Mission	Diplomatic	DNI Circuits
White House	Economic	DNR Circuits
Defense Intelligence Agency	Military	Mobile Wireless
National Counterterrorism Center	Political/Intention of Nations	
2 nd Party-GBR, NZL, CAN, AUS		
Office of Director of National Intelligence		
Joint Chiefs of Staff		
Department of Homeland Security		
Office of Secretary of Defense		
North Atlantic Treaty Organization		
Military Commands (Army, EUCEM)		
	Partnerships (Where)	Legal Authorities (Approvals)
	NSA - SSO, TAO, NTOC, CES, A&P...	NSA FISA
	CIA	CT FBI FISA
	FBI - Headquarters, NY, and DC	FISA Amendment Act (FAA)
	FBI - Engineering Research Facility	CI FBI FISA
	DOJ	BR FISA
	Commercial Providers	PR/TT FISA



BLARNEY Domestic Court Orders

Overseas Court Orders

Saudi Arabia
France
Germany
Russia

Afghanistan
Bank of Japan Domestic
Bosnia & Herzegovina
Brazil
Croatia
Cuba
Cyprus
Democratic People's Republic of Korea (N. Korea)
Egypt
European Union
France
Gabonese Republic (Gabon)
Georgia
Germany
Greece

India
Intl Bank for Reconstruction & Dev (World Bank)
Intl Monetary Fund (IMF)
Iran
Iraq
Israel
Italy
Japan
Jordan
Lebanon
Mexico
Nigeria
Pakistan
Palestine Liberation Org (PLO)
People's Republic of China (PRC)
Republic of Korea (S. Korea)
Russia

Saudi Arabia
Serbia
Sudan
Syria
Turkey
Uganda
Ukraine
United Nations
Known/unknown Agents of Al Qaeda & associated terrorists
Venezuela
Worldwide (FBI)
Yemen

As of July 2010



BLARNEY Access

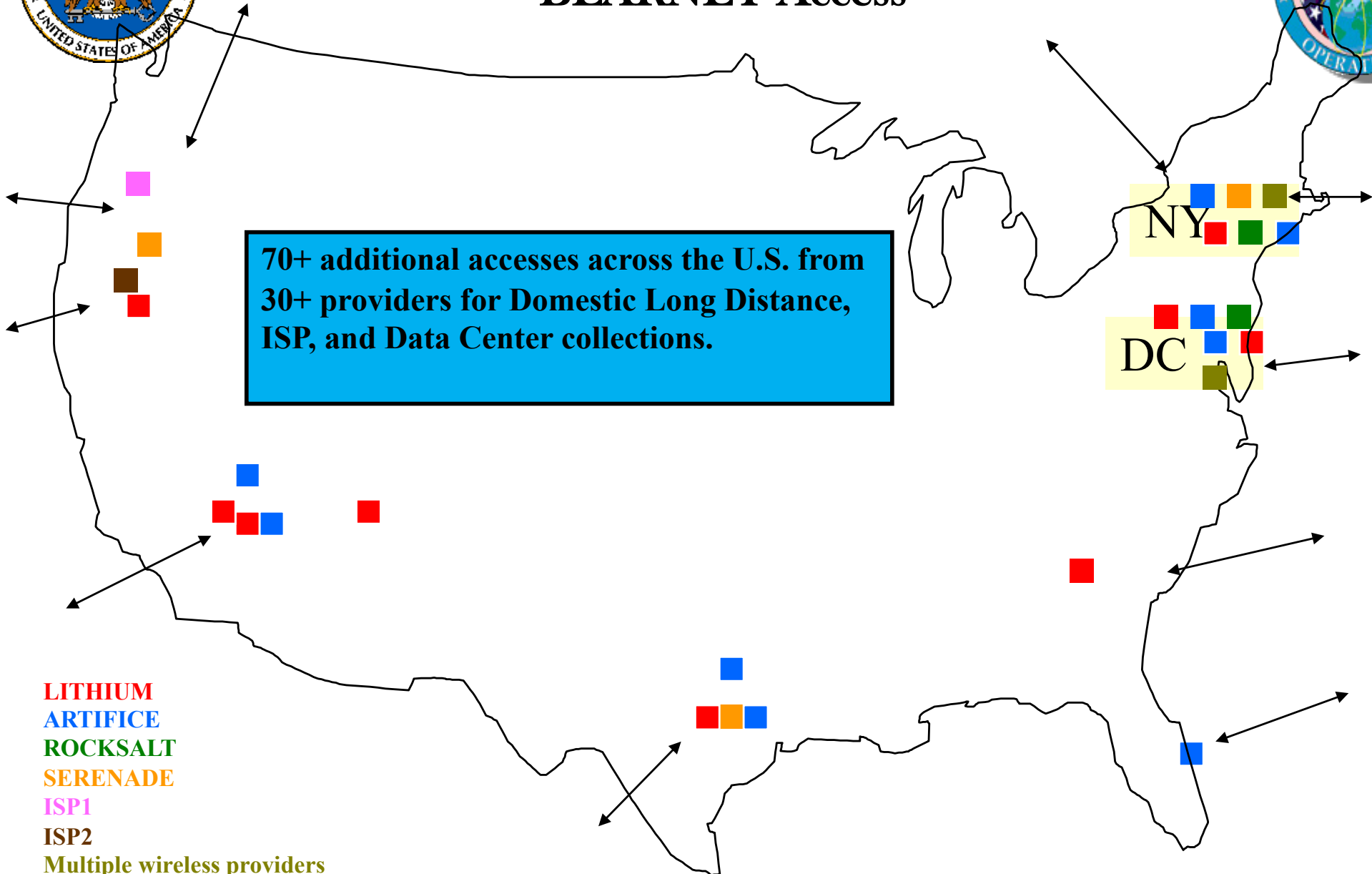



FAIRVIEW At a Glance

- Transit/FISA/FAA
- DNI/DNR (content & metadata)
- Domestic infrastructure only
- Cable Stations/Switches/Routers (IP Backbone)
- Close partnership w/FBI

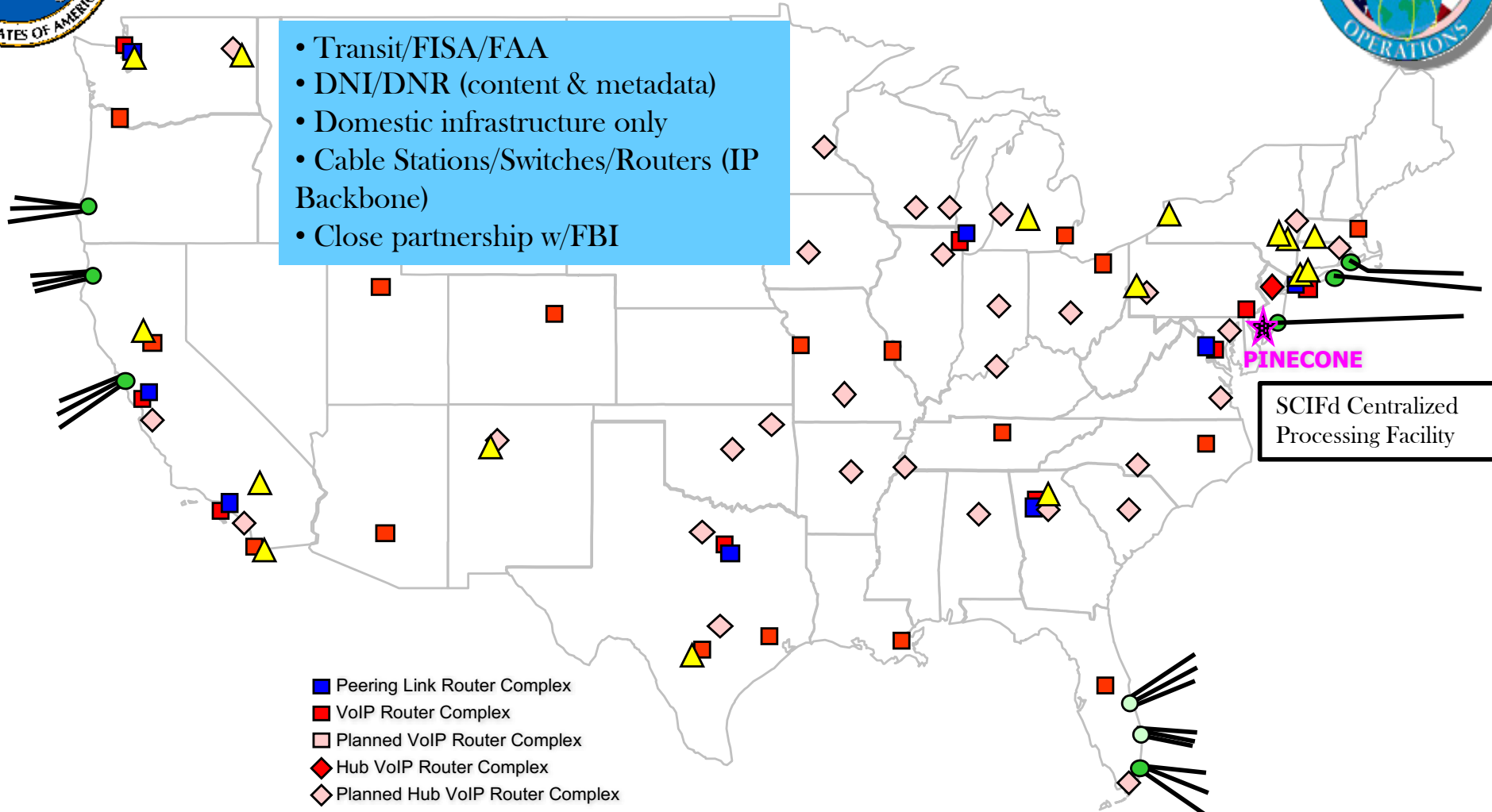

- Peering Link Router Complex
- VoIP Router Complex
- Planned VoIP Router Complex
- ◆ Hub VoIP Router Complex
- ◇ Planned Hub VoIP Router Complex
- Program Cable Station
- Planned Program Cable Station
- Non-program Cable Station
- ▲ Rimrock 4ESS Circuit Switch
- ★ Program Processing Site

SCIFd Centralized Processing Facility

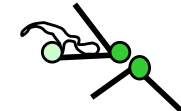
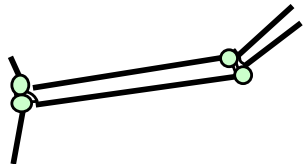

TOP SECRET//COMINT//REL TO USA, FVEY

(Report generated on:4/23/2013 7:00:17AM)

Blarney-40-12

Work in Progress

ECP Lead: [REDACTED]

Title of Change:

DNI Processing of RINGBILL Access

Site(s):

TITAN POINTE :

Project(s):

No Project(s) Entered

System(s):

VISIONQUEST :

SubSystem(s):

No Subsystem(s) Entered

Description of Change:

This is a partially historical ECP to track efforts performed for processing the DNI portion of RINGBILL. The initial processing of RINGBILL will be performed on our legacy WC2/XKS systems (using Trirame for VoIP & VTC traffic). Once we stand up SKIDROWE, the processing will transfer to that solution so we will need to be cognizant of any and all requirements that should be defined for the SKIDROWE team to enable our solution.

Because we are initially using our legacy systems there will be extra work required to configure them and the network to be capable of higher than normal throughput. There will also be work to determine what kind of filtering is required so that we don't overwhelm our PINWALE partitions. Finally, it is already apparent that further work will be required on the VoIP processing to associate signaling with media cuts. Once that is complete we will be able to look into filtering based on dialing patterns.

Reason for Change:

We now have access to the RINGBILL DNI and rather than waiting until the June/July timeframe to use the new solution for processing, we have developed an interim solution for processing the high data rates on existing architecture.

Mission Impact:

These efforts are an interim solution to process the RINGBILL signal months earlier than we originally planned. Resources will have to be prioritized against other efforts.

Additional Info:

Last CCB Entry:

04/10/13 15:44:43 [REDACTED]
09 Apr CCB - ECP status reviewed

<u>Work Task ID:</u>	WT00010435	<u>ECP Number:</u>	Blarney-40-12
<u>Status:</u>	Reassigned	<u>Description:</u>	Update Baseline - DNI Processing of RINGBILL Access
<u>Life Cycle Phase:</u>		<u>Assigned To:</u>	
<u>Last Log Entry:</u>	[REDACTED] --- 04/11/13 08:31:14 --- 4/11/13 - NTR		

<u>Work Task ID:</u>	WT00010584	<u>ECP Number:</u>	Blarney-40-12
<u>Status:</u>	Completed	<u>Description:</u>	Enable DNI Processing of RINGBILL through ng WC2 architecture
<u>Life Cycle Phase:</u>		<u>Assigned To:</u>	[REDACTED]
<u>Last Log Entry:</u>	[REDACTED] --- 04/11/13 08:31:49 --- 4/11/13 - NTR		

TOP SECRET//COMINT//REL TO USA, FVEY

(Report generated on:4/23/2013 7:00:17AM)

Work Task ID: WT00010585 **ECP Number:** Blarney-40-12
Status: Completed **Description:** Enable VoIP processing of RINGBILL desk
Life Cycle Phase: **Assigned To:** ██████████^{es}
Last Log Entry: ██████████ --- 04/11/13 08:32:25 --- 4/11/13 - NTR

Work Task ID: WT00010586 **ECP Number:** Blarney-40-12
Status: **Being Worked** **Description:** Deploy SKIDROWE solution for RINGBILL DNI Processing
Life Cycle Phase: **Assigned To:** ██████████
Last Log Entry: ██████████ --- 04/03/13 15:51:25 --- XKS has been loaded on the two SR systems at TP. The TW release is expected by the end of April, though this may push out again. There are some planned RPM updates for XKS that will be installed next week.

Work Task ID: WT00010586-1 **ECP Number:** Blarney-40-12
Status: Completed **Description:** Define RINGBILL Hardware Requirements
Life Cycle Phase: **Assigned To:** ██████████
Last Log Entry: ██████████ --- 04/11/13 08:33:02 --- 4/11/13 - NTR

Work Task ID: WT00010586-2 **ECP Number:** Blarney-40-12
Status: Completed **Description:** Order Skidrow Equipment
Life Cycle Phase: **Assigned To:** ██████████
Last Log Entry: ██████████ --- 08/22/12 13:56:48 --- Order equipment for the RINGBILL SKIDROWE system

Work Task ID: WT00010586-3 **ECP Number:** Blarney-40-12
Status: Completed **Description:** Order Additional Parts
Life Cycle Phase: **Assigned To:** ██████████
Last Log Entry: ██████████ --- 01/16/13 09:33:07 --- All equipment associated with the RINGBILL SKIDROWE has been ordered and received. Closing worktask.

Work Task ID: WT00010586-4 **ECP Number:** Blarney-40-12
Status: Completed **Description:** Recieve Ordered Equipment
Life Cycle Phase: **Assigned To:** ██████████
Last Log Entry: ██████████ --- 08/22/12 14:03:13 --- Receive equipment that was ordered.

TOP SECRET//COMINT//REL TO USA, FVEY

(Report generated on:4/23/2013 7:00:17AM)

Work Task ID: WT00010586-5 **ECP Number:** Blarney-40-12
Status: **Being Worked** **Description:** Stand up Test System
Life Cycle Phase: **Assigned To:**
Last Log Entry: [REDACTED] --- 04/03/13 15:52:20 --- XKS has been upgraded to 1.5.11 and we have begun to test, though we need to install some patches before we can continue. We are still waiting for TW software.

Work Task ID: WT00010586-6 **ECP Number:** Blarney-40-12
Status: Completed **Description:** Test the RINGBILL SKIDROWE Servers.
Life Cycle Phase: **Assigned To:** [REDACTED]
Last Log Entry: [REDACTED] --- 12/05/12 15:57:17 --- Servers have been installed at site and powered on. Closing ticket.

Work Task ID: WT00010586-7 **ECP Number:** Blarney-40-12
Status: Completed **Description:** Install 10G NICs in each RINGBILL SKIDROWE
Life Cycle Phase: **Assigned To:** [REDACTED]
Last Log Entry: [REDACTED] --- 12/05/12 16:00:07 --- Completed.

Work Task ID: WT00010586-8 **ECP Number:** Blarney-40-12
Status: Completed **Description:** Design Site Plan
Life Cycle Phase: **Assigned To:** [REDACTED]
Last Log Entry: [REDACTED] --- 01/16/13 09:39:48 --- Rack elevations and network plan has been developed an has been incorporated into site documentation. Closing ticket.

Work Task ID: WT00010586-9 **ECP Number:** Blarney-40-12
Status: Completed **Description:** Transport Equipment to Site
Life Cycle Phase: **Assigned To:** [REDACTED]
Last Log Entry: [REDACTED] --- 02/21/13 14:50:16 --- Equipment has been shipped to site and installed. Closing ticket.

Work Task ID: WT00010586-10 **ECP Number:** Blarney-40-12
Status: **Assigned** **Description:** Load System and Test Functionality
Life Cycle Phase: **Assigned To:**
Last Log Entry: [REDACTED] --- 04/11/13 08:34:12 --- 4/11/2013 - NTR

TOP SECRET//COMINT//REL TO USA, FVEY

(Report generated on:4/23/2013 7:00:17AM)

Work Task ID: WT00010586-11 **ECP Number:** Blarney-40-12
Status: Completed **Description:** Duplicate RINGBILL Signal to the SKIDROWE
Life Cycle Phase: **Assigned To:** ██████^m
Last Log Entry: ██████ --- 02/21/13 14:00:40 --- Signal has been duplicated with a 30/70 splitter. When we're ready to start processing we'll have to see if the light levels are good enough. ██████ also has a 50/50 splitter at site that we can try if need be. Marking as complete and will reopen if further work needs to be performed.

Work Task ID: WT00010586-12 **ECP Number:** Blarney-40-12
Status: **Assigned** **Description:** Declare System IOC
Life Cycle Phase: **Assigned To:**
Last Log Entry: ██████ --- 04/11/13 08:35:55 --- NTR

Work Task ID: WT00010586-13 **ECP Number:** Blarney-40-12
Status: **Assigned** **Description:** Decommission WCT05
Life Cycle Phase: **Assigned To:**
Last Log Entry: ██████ --- 04/11/13 08:36:10 --- NTR

Work Task ID: WT00010586-14 **ECP Number:** Blarney-40-12
Status: Completed **Description:** Perform Site Survey
Life Cycle Phase: **Assigned To:** ██████
Last Log Entry: ██████ --- 08/22/12 14:24:44 --- Completed 6/26/12

Work Task ID: WT00010586-15 **ECP Number:** Blarney-40-12
Status: Completed **Description:** Conduct System Design Review
Life Cycle Phase: **Assigned To:** ██████
Last Log Entry: ██████ --- 01/16/13 09:35:03 --- This was completed as part of the ERB. Closing ticket.

Work Task ID: WT00010586-16 **ECP Number:** Blarney-40-12
Status: Completed **Description:** Obtain ETS TD Approval of System Design
Life Cycle Phase: **Assigned To:** ██████
Last Log Entry: ██████ --- 01/16/13 09:35:34 --- Completed during the ERB for SKIDROWE. Closing ticket.

TOP SECRET//COMINT//REL TO USA, FVEY

(Report generated on:4/23/2013 7:00:17AM)

<u>Work Task ID:</u>	WT00010586-17	<u>ECP Number:</u>	Blarney-40-12
<u>Status:</u>	Completed	<u>Description:</u>	ERB Processing Recommendation Matrix
<u>Life Cycle Phase:</u>		<u>Assigned To:</u>	██████████
<u>Last Log Entry:</u>	██████████ --- 01/16/13 09:36:08 --- ERB presentation was completed and approved. Closing ticket.		

<u>Work Task ID:</u>	WT00010586-18	<u>ECP Number:</u>	Blarney-40-12
<u>Status:</u>	Completed	<u>Description:</u>	Schedule/Conduct Depolyment Readiness w (DRR)
<u>Life Cycle Phase:</u>		<u>Assigned To:</u>	██████████
<u>Last Log Entry:</u>	██████████ --- 01/16/13 09:36:39 --- This was completed as part of the ERB. Closing ticket.		

TOP SECRET//COMINT//REL TO USA, FVEY

(Report generated on:4/23/2013 7:00:17AM)

Blarney-55-12

Work in Progress

ECP Lead: [REDACTED]

Title of Change:

Deployment of TURTLEPOWER system in VQ environment

Site(s):

No Site(s) Entered

Project(s):

No Project(s) Entered

System(s):

VISIONQUEST :

SubSystem(s):

No Subsystem(s) Entered

Description of Change:

This ECP will encompass working with CES ([REDACTED]) to stand up and forward deploy a TURTLEPOWER system for the purpose of processing VoIP. Installation will occur [REDACTED] followed by deployment to TP and testing against the RINGBILL data. If successful we could turn this into an operational system and work through the details for tasking and number normalization.

Reason for Change:

The primary purpose of this system will be to determine its VoIP processing capabilities, though other capabilities will likely be examined as well. Trireme requires some development to support desk phone conversations of the RINGBILL data and it has been conveyed that TURTLEPOWER has the capability already. We are proposing deploying a TURTLEPOWER system to test this capability and potentially provide a solution for forwarding SIGINT to the TOPIs in a compressed timeframe (comparitvely to the Trireme solution.

This also provides BLARNEY an opportunity to help TURTLEPOWER develop their capabilities by using potentially unique data found in the BLARNEY environments. Any derived enhancements to TURTLEPOWER will help the agency as a whole.

Mission Impact:

This effort will potentially allow us to deliver RINGBILL voice cuts to the TOPI sooner than waiting for the Trireme solution. It also allows us to make sure we're using the best processing solution for the job.

This will be worked in accordance to priorities as set by the BAT branch so other mission will not be negatively impacted.

Additional Info:

Last CCB Entry:

04/10/13 15:47:00 [REDACTED]
09 Apr CCB - ECP status reviewed.

<u>Work Task ID:</u>	WT00010899	<u>ECP Number:</u>	Blarney-55-12
<u>Status:</u>	New	<u>Description:</u>	Update Baseline - Deployment of TURTLEPOWER system in VQ environment
<u>Life Cycle Phase:</u>		<u>Assigned To:</u>	[REDACTED]
<u>Last Log Entry:</u>	None ATT		

<u>Work Task ID:</u>	WT00010944	<u>ECP Number:</u>	Blarney-55-12
<u>Status:</u>	Completed	<u>Description:</u>	Installation and configuration of initial TP server
<u>Life Cycle Phase:</u>		<u>Assigned To:</u>	[REDACTED]
<u>Last Log Entry:</u>	[REDACTED] --- 12/05/12 15:50:37 --- System has been deployed, configured, and is processing operational data. A DMR was submitted and approved prior to going live with operational processing on November 16th. Marking ticket completed as this system is now in an operational capacity.		

TOP SECRET//COMINT//REL TO USA, FVEY

(Report generated on:4/23/2013 7:00:17AM)

<u>Work Task ID:</u>	WT00010945	<u>ECP Number:</u>	Blarney-55-12
<u>Status:</u>	Being Worked	<u>Description:</u>	Analysis of Turtlepower Processing in BLARNEY
<u>Life Cycle Phase:</u>		<u>Assigned To:</u>	
<u>Last Log Entry:</u>	[REDACTED] --- 04/03/13 15:49:37 --- Test data has been provided to PE to further develop against non SKINNY protocols in an effort to perform processing against a broader scope of data. We are currently waiting for their feedback on progress and what it would take to improve the system performance.		