



NATIONAL TRANSPORTATION SAFETY BOARD
Office of Aviation Safety
Washington, DC 20594

March 7, 2013

Interim Factual Report

NTSB Case Number: DCA13IA037
Location: Boston, Massachusetts
Date: January 7, 2013
Aircraft/Operator: Boeing 787-8, JA829J, Japan Airlines

Contents

Figures.....	iii
Tables	iv
Abbreviations and Acronyms	v
Executive Summary	vii
1. Factual Information.....	1
1.1 Event History	1
1.2 Airplane Information	4
1.3 Battery Information.....	5
1.4 Flight Recorders.....	10
1.5 Battery Examinations.....	12
1.5.1 External Observations.....	12
1.5.2 Battery Disassembly	15
1.5.3 Battery Case Protrusion and Corresponding Cell Case Damage	20
1.5.4 Radiographic Examinations.....	21
1.6 Component Testing.....	25
1.6.1 Battery Charger Unit.....	25
1.6.2 Start Power Unit.....	26
1.6.3 Battery Monitoring Unit	26
1.6.4 Contactor.....	28
1.6.5 Auxiliary Power Unit Controller	29
1.7 System Safety and Certification.....	29
1.7.1 Type Certification and Battery Special Conditions	29
1.7.2 Certification Plan	31
1.7.3 System Safety Assessment.....	31
1.8 Federal Aviation Administration Actions After Battery Incidents	33
1.9 Additional Information	34
2. Ongoing and Planned Investigation Activities	35
Appendix—Boeing 787 Type Certification Special Conditions 25-359-SC	38

Figures

Figure 1. Smoke emanating from the aft electronic equipment bay.	3
Figure 2. Main and auxiliary power unit battery locations.	6
Figure 3. 787 Main and auxiliary power unit exemplar battery.....	7
Figure 4. Electrical schematic of the main and auxiliary power unit battery.	8
Figure 5. Auxiliary power unit installation location with battery removed.	9
Figure 6. Side 1 (forward face) of the battery case.	12
Figure 7. Side 2 (left side) of the battery case.	13
Figure 8. Side 3 (aft face) of the battery case.	14
Figure 9. Side 4 (right side) of the battery case.	15
Figure 10. Battery case with side 2 folded down.	16
Figure 11. Battery case with side 4 folded down.	17
Figure 12. Battery case with side 3 folded down.	18
Figure 13. Views of cell 6.....	19
Figure 14. Protrusion on the lower left of battery cases side 3.....	20
Figure 15. Cross-sectional view of the auxiliary power unit battery.	22
Figure 16. Top view of cell 5 showing cell wall breach.	23
Figure 17. Three-dimensional view of aluminum current collectors in cell 6.....	24
Figure 18. Granularity noted in top view of cell 7.....	25
Figure 19. Battery monitoring unit main board.	27

Tables

Table 1. Battery and cell specifications.	7
Table 2. Events surrounding auxiliary power unit shutdown.....	11
Table 3. Battery safety requirements.....	32

Abbreviations and Acronyms

AD	airworthiness directive
ALPA	Air Line Pilots Association
APU	auxiliary power unit
ARFF	aircraft rescue and firefighting
ATP	acceptance test procedure
BCU	battery charger unit
BEA	Bureau d'Enquêtes et d'Analyses pour la Sécurité de l'Aviation Civile
BMU	battery monitoring unit
BOS	General Edward Lawrence Logan International Airport
CFR	<i>Code of Federal Regulations</i>
CT	computed tomography
CVR	cockpit voice recorder
EAFR	enhanced airborne flight recorder
EASA	European Aviation Safety Agency
EDS	energy dispersive x-ray spectroscopy
E/E bay	electronic equipment bay
EICAS	engine indicating and crew alerting system
FAA	Federal Aviation Administration
FDR	flight data recorder
JAL	Japan Airlines
JTSB	Japan Transport Safety Board
KAI	Kanto Aircraft Instrument Company

NRT	Narita International Airport
NTSB	National Transportation Safety Board
NVM	nonvolatile memory
SEM	scanning electron microscope
SPU	start power unit

Executive Summary

The National Transportation Safety Board (NTSB) notes that the information discussed in this interim factual report is based on initial findings from the investigation of this incident. Because the investigation is continuing, no conclusions or recommendations are being made at this time. Readers are encouraged to access the [public docket](#) for this incident (DCA13IA037) for further details about the information presented in this report.¹ In addition, readers are advised that the information presented in this report could change if new evidence becomes available.

On January 7, 2013, about 1021 eastern standard time, smoke was discovered by cleaning personnel in the aft cabin of a Japan Airlines (JAL) Boeing 787-8, JA829J, which was parked at a gate at General Edward Lawrence Logan International Airport (BOS), Boston, Massachusetts. About the same time, a maintenance manager in the cockpit observed that the auxiliary power unit (APU)—the sole source of airplane power at the time—had automatically shut down. Shortly afterward, a mechanic opened the aft electronic equipment (E/E) bay and found heavy smoke and fire coming from the front of the APU battery case.² No passengers or crewmembers were aboard the airplane at the time, and none of the maintenance or cleaning personnel aboard the airplane was injured. Aircraft rescue and firefighting personnel responded, and one firefighter received minor injuries. The airplane had arrived from Narita International Airport, Narita, Japan, as a regularly scheduled passenger flight operated as JAL flight 008 and conducted under the provisions of 14 *Code of Federal Regulations* Part 129.

The APU battery provides power to start an APU during ground and flight operations. Flight data recorder (FDR) data showed that the APU was started about 1004 while the airplane was being taxied to the gate after arrival at BOS. The FDR data also showed that, about 36 seconds before the APU shut down at 1021:37, the voltage of the APU battery began fluctuating, dropping from a full charge of 32 volts to 28 volts about 7 seconds before the shutdown.

The APU battery consists of eight lithium-ion cells that are connected in series and assembled in two rows of four cells. Each battery cell has a nominal voltage of

¹ The public docket for this incident, DCA13IA037, can be accessed at the NTSB's website at <http://www.nts.gov/investigations/dms.html>.

² The mechanic provided a written statement to the NTSB describing his observations. The mechanic's statement indicated that, after he checked the aft E/E bay, he saw "heavy smoke in the compartment." He also reported that he "saw small flame around APU batt[ery]." He added that he "decided [to] discharge [the fire] extinguisher" but could not "discharge continuously" because he believed that there was a "dangerous environment in the compartment." In addition, he stated that he "tried fire extinguishing, but smoke and flame (flame size about 3 inch[es]) did not stop." The maintenance manager also provided a written statement to the NTSB, which indicated that the mechanic had seen "flames around the APU battery."

3.7 volts. The cells have a lithium cobalt oxide compound chemistry and contain a flammable electrolyte liquid.

External observations of the battery involved in this incident showed, among other things, that the right side of the battery case appeared to have the most extensive damage of the four battery sides.³ Disassembly of the battery revealed that the cells that were located in the left side of the battery (cells 1 through 4) generally exhibited the least thermal and mechanical damage and that the cells that were located in the right side of the battery (cells 5 through 8) generally exhibited the most thermal and mechanical damage. Thermal damage was the most severe near cell 6. Continuity measurements using a digital volt meter indicated that all of the cells were found to be electrically short circuited except for cell 8.

The APU battery was configured so that each cell's vent disc, which is a plate that ruptures when the internal pressure in a cell reaches a predetermined level, would be oriented toward the exterior of the battery. Disassembly of the battery showed that the vent discs on cells 1 through 3 were opened slightly, the cell 4 vent disc was intact (although weight measurements indicated that the cell lost some electrolyte), and the vent discs on cells 5 through 8 had opened more completely, leaving a ruptured appearance.⁴

The NTSB is examining the certification and testing of the 787 battery system as part of its investigation of this incident. According to the Federal Aviation Administration (FAA), the 787 incorporated "novel or unusual design features," including the use of lithium-ion batteries. Because the FAA determined that applicable airworthiness requirements did not address lithium-ion batteries, the agency issued nine special conditions regarding the use of these batteries on the 787. These nine special conditions were intended to ensure that this new technology would not pose a greater safety risk than other technologies addressed in existing airworthiness regulations.

During the 787 certification process, Boeing performed a safety assessment (known as functional hazard assessment) to determine the potential hazards that various failure conditions of electrical system components could introduce to the airplane and its occupants. Boeing also determined that the probability that a battery could vent was once in every 10 million flight hours. As of January 16, 2013, the in-service 787 fleet had accumulated less than 52,000 flight hours, and during this period two events involving smoke emission from a 787 battery (the BOS event and a second event in Japan being

³ References in this report to the battery's right and left sides are from an aft-facing orientation in the airplane unless otherwise specified.

⁴ The vent discs are scored with an "x" pattern, which enables preferential tearing when the disc ruptures, creating four independent petals. For the vent discs that were slightly open, the four petals had slightly parted but remained in the same plane. For the vent discs that were completely open, the four petals were splayed out and positioned out of plane with the discs' original position, which was indicative of a more forceful opening.

investigated by the Japan Transport Safety Board) had occurred on two different 787 airplanes.

The NTSB's investigation into the probable cause of the 787 battery fire at BOS is continuing. The NTSB is also continuing to review the design, certification, and manufacturing processes for the 787 lithium-ion battery system.

1. Factual Information

1.1 Event History

On January 7, 2013, about 1021 eastern standard time,⁵ smoke was discovered by cleaning personnel in the aft cabin of a Japan Airlines (JAL) Boeing 787-8, JA829J, which was parked at a gate at General Edward Lawrence Logan International Airport (BOS), Boston, Massachusetts. About the same time, a maintenance manager in the cockpit observed that the auxiliary power unit (APU)⁶ had automatically shut down. Shortly afterward, a mechanic opened the aft electronic equipment bay (E/E bay) and found heavy smoke and fire coming from the front of the APU battery case.⁷ No passengers or crewmembers were aboard the airplane at the time,⁸ and none of the maintenance or cleaning crew aboard the airplane was injured. Aircraft rescue and firefighting (ARFF) personnel responded, and one firefighter received minor injuries. The airplane had arrived from Narita International Airport (NRT), Narita, Japan, as a regularly scheduled passenger flight operated as JAL flight 008 and conducted under the provisions of 14 *Code of Federal Regulations* (CFR) Part 129.⁹

The captain of JAL flight 008 reported that the APU was turned on about 30 to 40 minutes before the airplane left the gate at NRT (at 0247Z)¹⁰ and was shut down after the engines started. He stated that the flight, which departed NRT at 0304Z, was uneventful except for occasional moderate turbulence about 6.5 to 7 hours into the flight. Flight data recorder (FDR) data showed that the airplane touched down at BOS at 1000:24 and that the APU was started at 1004:10 while the airplane was taxied to the gate. The captain indicated that the APU operated normally. FDR data also showed that the airplane was parked at the gate with the parking brake set and both engines shut down by 1006:54.

⁵ All times in this report are eastern standard time unless otherwise noted.

⁶ The APU battery provides power to start an APU during ground and flight operations. The APU controller (discussed in section 1.6.5) monitors the parameters that are needed to operate the APU. The APU controller is powered by the APU battery bus, which receives its power from the APU battery. If the APU battery fails, then the APU battery bus will no longer receive power, and the APU will shut down.

⁷ The mechanic's written statement appears in the executive summary for this report.

⁸ The airplane had been carrying 183 passengers and 11 crewmembers.

⁹ Parties to the NTSB's investigation are the Federal Aviation Administration and Boeing Commercial Airplanes. In accordance with the provisions of Annex 13 to the Convention on International Civil Aviation, the Japan Transport Safety Board (JTSB) and the Bureau d'Enquêtes et d'Analyses pour la Sécurité de l'Aviation Civile (BEA) are participating in this investigation. Japan Airlines and GS Yuasa (the manufacturer of the 787 main and APU batteries) are participating in the investigation as technical advisors to the JTSB, and Thales Avionics Electrical Systems (the manufacturer of the 787 electrical power conversion subsystem) and the European Aviation Safety Agency are participating in the investigation as technical advisors to the BEA, as provided for in Annex 13. Technical assistance to the NTSB is being provided by the Carderock Division of the Naval Surface Warfare Center, US Department of the Navy.

¹⁰ Eastern standard time is 5 hours behind coordinated universal time (also referred to as UTC or Zulu time).

The maintenance manager (the JAL director of aircraft maintenance and engineering at BOS) reported that the passengers had deplaned by 1015 and that the flight and cabin crewmembers had deplaned by 1020, at which time he and the cabin cleaning crew had entered the airplane. Shortly afterward, a member of the cleaning crew reported to the maintenance manager, who was in the cockpit, “an electrical burning smell and smoke in the aft cabin.” The maintenance manager then observed a loss of power to systems powered by the APU and realized that the APU had automatically shut down. After confirming that the airplane’s electrical power systems were off, the maintenance manager turned the APU and main battery switches to the “off” position. FDR data showed that the APU battery failed at 1021:15¹¹ and that the APU shut down at 1021:37, which was also the time that the APU controller lost power.

A JAL mechanic in the aft cabin at the time reported that, when power to the airplane was lost, he went to the cockpit and learned that the APU had shut down. The mechanic then went back to the aft cabin, saw and smelled smoke, and notified the maintenance manager, who asked the mechanic to check the aft E/E bay. The mechanic found heavy smoke in the compartment and a fire at the front of the APU battery case.¹² He indicated that the fire had two distinct flames that were about 3 inches in length at the two connectors on the front of the battery case.¹³ A JAL station manager arrived at the airplane and reported that, when he went into the cabin (through the door where the passenger boarding bridge is attached), he saw “intense” smoke that was concentrated 10 feet aft of the door. The turn-around coordinator for JAL flights 008 and 829,¹⁴ who had also observed the smoke in the aft cabin, described the smoke as “caustic smelling.” The mechanic reported that he used a dry chemical fire extinguisher (located at the base of the bridge) to try to put out the fire but that the smoke and flames did not stop.¹⁵

ARFF personnel at BOS were notified at 1037 about smoke in the cabin of a JAL airplane.¹⁶ Review of a time-stamped airport security camera video showed that the first of five ARFF trucks arrived on scene within 1 minute (at 1037:50).¹⁷ (A ladder truck, a rescue truck, an airstair truck, a hazardous materials truck, and a fire command vehicle also responded to the incident.)

¹¹ The FDR “ELEC_APU_BATTERY” parameter recorded “failure” at this time.

¹² The front of the battery case is oriented toward the front of the airplane.

¹³ The JAL mechanic reported this information to two NTSB investigators during the on-scene portion of this investigation.

¹⁴ JAL flight 829 had been scheduled to depart BOS later that morning using the incident airplane.

¹⁵ A fire extinguisher is used to take away one of the three components of a fire: fuel, oxygen, and heat. Fire extinguisher applicability depends on the type of agent inside. The fire extinguisher used during this incident had a dry chemical (inert solid) agent, which is used to suffocate and/or smother a fire by taking away the oxygen component.

¹⁶ The JAL station manager stated that he asked a gate agent to call ARFF. The gate agent then called her supervisor, who called ARFF from a telephone at the passenger check-in counter.

¹⁷ The airplane was located at gate 8A in terminal E. At the time of the incident notification, the first ARFF truck to reach the scene was already at terminal E for terminal familiarization training. The airport security camera recording times were correlated to the FDR times (within 3 seconds).

The JAL mechanic advised ARFF personnel that the fire was in the aft E/E bay and led a firefighter to the aft E/E bay door. The firefighter reported that, after entering the compartment, “a white glow about the size of a softball” could be seen on a hand-held thermal imaging camera¹⁸ and that he applied “a shot” of Halotron (a clean fire-extinguishing agent)¹⁹ to try to knock down the fire.²⁰ The thermal imaging camera showed that the white glow was still present but was less than before. The airport security camera video showed smoke coming out of the airplane, as shown in figure 1, at 1040:26.



Figure 1. Smoke emanating from the aft electronic equipment bay.

Source: *Boston Herald*.

¹⁸ The hand-held thermal imaging cameras used by ARFF personnel had a heat-density scale portrayed as brightness and/or coloring of an object (that is, the more white and bright the object, the higher the heat intensity). Also, the forward-looking infrared cameras on ARFF vehicles had a temperature evaluation capability. These cameras were used when ARFF personnel initially arrived on scene, and the cameras showed no distinct heat patterns or signatures.

¹⁹ According to the Halotron website, “Halotron is a rapidly evaporating liquid...that leaves no residue, thereby minimizing or eliminating potential agent-related damage to...assets like electronic equipment, machinery, motors and construction materials.” Halotron is dispersed at a rate of 5 pounds per second. A “quick shot” of Halotron was estimated to last between 15 and 20 seconds, corresponding to between 75 and 100 pounds of the fire-extinguishing agent dispersed. Halotron is effective in controlling the spread of a lithium-ion battery fire. ARFF personnel are trained to use a clean agent, such as Halotron, in electrical and avionics compartments because water will ruin electrical and avionics components.

²⁰ The term “fire” is commonly used by ARFF personnel in reference to an ARFF response or event. Although the JAL mechanic reported that flames were coming from the front of the APU battery case, none of the ARFF personnel who responded to this incident reported seeing flames.

An ARFF captain went into the aft E/E bay with the thermal imaging camera, which showed a heat signature near the APU battery. After he came out of the E/E bay, another firefighter entered it. This firefighter reported no visibility because of the smoke. He did not know where the battery was located within the E/E bay, but he knew of a “hot spot” about 6 to 8 inches in front of him, so he discharged a “quick burst” of Halotron for 10 to 20 seconds. The firefighter exited and reentered the E/E bay with the thermal imaging camera. He reported that the battery case was visible, and he saw “a white glow with radiant heat waves” but no flames.

An ARFF lieutenant reported that the battery appeared to be rekindling. The ARFF captain reentered the E/E bay and saw heavy white smoke (which he had seen earlier billowing through the floor of the aft cabin) but no flames. The captain applied shots of Halotron to the fire for 5 minutes, which he believed had knocked down the fire. He reported that the battery was emitting white smoke, creating heavy smoke conditions. The captain also reported that the battery was hissing loudly and that liquid was flowing down the sides of the battery case. A firefighter reported that he heard a “pop” sound and that smoke began “pouring out of” the aft E/E bay. (The ARFF captain received a burn on his neck when the battery, in his words, “exploded.”)

After additional firefighting efforts and the placement of a ventilation fan by the E/E bay door to clear smoke,²¹ the incident commander made the decision to remove the APU battery.²² Firefighters reported that removing the battery was difficult because a metal kick shield installed in front of the battery prevented them from accessing the battery’s quarter-turn quick disconnect knob. Also, the quick disconnect knob could not be turned because it was charred and melted. The airport security camera video showed that the battery was removed from the aft E/E bay at 1157:20,²³ about 80 minutes after the initial notification of the event. The ARFF incident report showed that the event was “controlled” at 1219, about 1 hour 40 minutes after the initial notification. The National Transportation Safety Board’s (NTSB) investigation of the event began later that day.

1.2 Airplane Information

The Boeing 787 “Dreamliner” is a twin-engine, wide-body commercial airplane. The 787 program began in April 2004, with the 787’s first flight occurring in December 2009, certification occurring in August 2011, and first delivery occurring in

²¹ The airport security camera video showed that, at 1105:58, smoke was no longer visible from the exterior of the airplane.

²² The incident commander also asked a JAL mechanic and a firefighter to disconnect the main battery as a precaution in case it was feeding the APU battery fire.

²³ ARFF personnel had to cut the kick shield installed in front of the battery case to access to the battery and then cut the connectors to the battery to remove it.

September 2011. Boeing reported that, as of January 16, 2013, the 50 in-service airplanes comprising the 787 fleet had accumulated 51,662 flight hours and 18,665 cycles.²⁴

The airplane involved in this incident, JA829J, was delivered to JAL on December 20, 2012. At the time of the battery fire, the airplane had logged 169 flight hours and 22 flight cycles.

Boeing worked with numerous companies around the world to develop major structural and system components for the 787. Boeing contracted with Thales Avionics Electrical Systems of France to design the 787 electrical power conversion subsystem, which is part of the airplane's electrical power system. Thales then subcontracted with various manufacturers for the main and APU battery system components.

The APU battery installed on the incident airplane was manufactured by GS Yuasa Corporation in Kyoto, Japan, in September 2012 and was delivered new to Boeing. The battery had eight individual lithium-ion cells, all of which came from the same manufacturing lot produced by GS Yuasa in July 2012. The battery was installed in the incident airplane on October 15, 2012, and was initially charged by the airplane on or about October 19, 2012. Boeing records showed that the battery was disconnected (but not removed from the airplane) on December 5, 2012, as a precaution while an electrical power panel was inspected for foreign object damage. The battery was reconnected the next day.

1.3 Battery Information

As previously stated, the APU battery (in the aft E/E bay) provides power to start the APU (in the tail of the airplane) during ground and flight operations. The same battery model is also used for the 787 main battery, which is located in the forward E/E bay.²⁵ The main battery provides power to selected electrical/electronic equipment during ground and flight operations for normal and failure conditions. The battery model is unique to the 787. Figure 2 shows the locations of the main and APU batteries aboard the 787.

²⁴ One cycle comprises a complete engine startup and shutdown. The total number of 787 flight hours indicated does not include about 6,000 flight test hours.

²⁵ According to the JTSCB, on January 16, 2013, a "serious incident" involving the main battery occurred aboard a 787 airplane operated by All Nippon Airways during a flight from Yamaguchi to Tokyo, Japan. The airplane made an emergency landing in Takamatsu, Japan, shortly after takeoff. The JTSCB is investigating this incident with support from the NTSB.

787 SERIES

BATTERY LOCATIONS

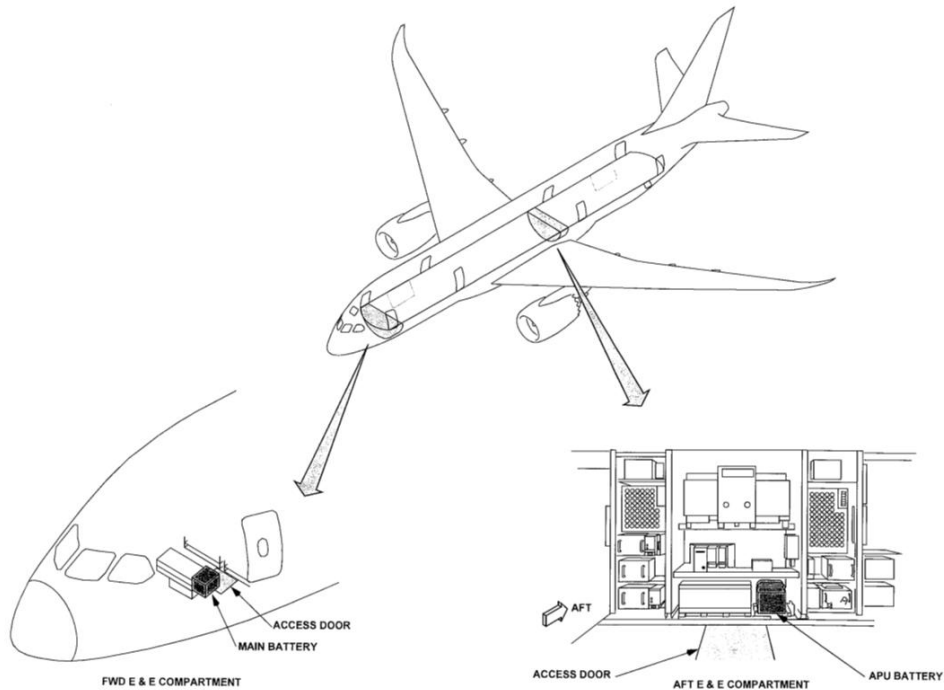

Figure 2. Main and auxiliary power unit battery locations.

Source: Boeing.

The main and APU battery, as shown in figure 3, consists of eight lithium-ion cells that are connected in series and assembled in two rows of four cells. Table 1 shows the specifications for the APU battery and cells. The insulation sheets provide electrical insulation and physical separation between each cell and between the cells and the aluminum battery case, which is electrically grounded. An upper and a lower fixation tray secure the position and orientation of the cells in the battery case.

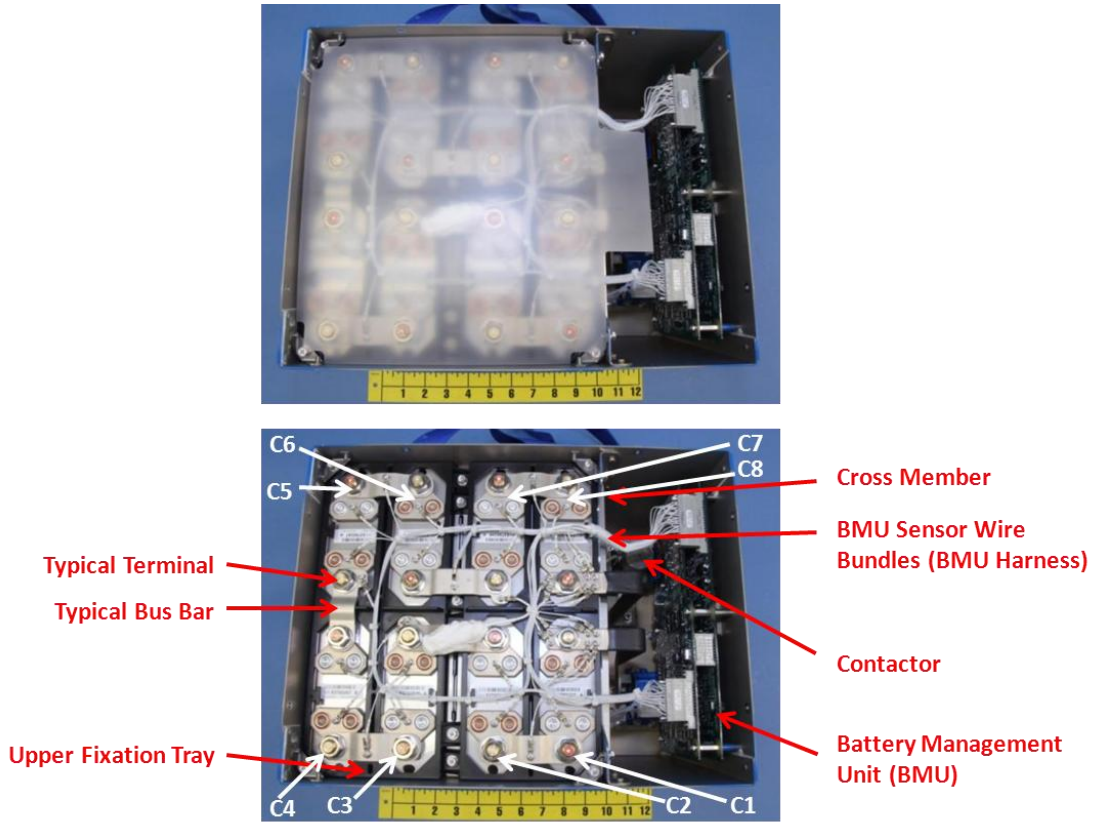

Figure 3. 787 Main and auxiliary power unit exemplar battery.

Table 1. Battery and cell specifications.

Specification	Battery	Cell
Nominal capacity (ampere-hour)	75	75
Nominal voltage (volts)	29.6	3.7
Operational voltage range (volts)	20 to 32.2	2.5 to 4.025
Weight (pounds)	61.8	6
Dimensions (inches)		
Width	10.9	5.2
Depth	14.2	2.0
Height	8.5	7.7

Note: Battery specification information was based on information from a Thales document. Cell specification information was provided by GS Yuasa.

Each cell has three internal electrode winding assemblies. Each winding assembly is about 33 feet in length and is configured with an electrode, then a separator, then another electrode, and then another separator. One electrode (the anode) is a copper foil coated in carbon; the other electrode (the cathode) is an aluminum foil coated in a lithium cobalt compound. Lithium-ion batteries have primarily nonflammable components, but the electrolyte is flammable, and active material coatings on the negative (anode) and positive (cathode) electrodes contain chemically reactive components.

In addition to the eight individual battery cells, the battery case contains two circuit boards that comprise the battery monitoring unit (BMU, discussed in section 1.6.3); a Hall effect current sensor for current monitoring; a contactor (discussed in section 1.6.4); bus bars for the main current pathways between the cells and to the J3 connector, which leads outside of the battery case; and sense wires leading to the BMU and the J1 connector (also referred to as the cannon plug port), which also leads outside of the battery case.²⁶ Figure 4 shows these battery components. Information about the APU battery and cells involved in this incident appears in section 1.5.

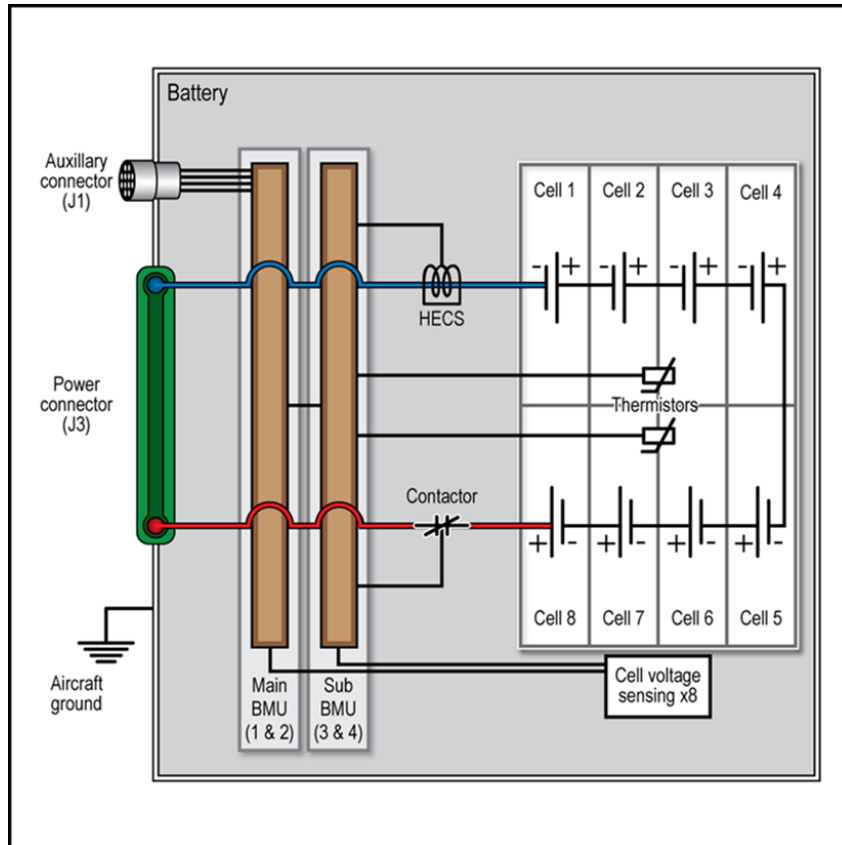

Figure 4. Electrical schematic of the main and auxiliary power unit battery.

The APU battery installation location, the aft E/E bay, is an electrical equipment compartment. This compartment is located aft of the main landing gear and beneath approximately the third set of cabin doors (L3 and R3). The compartment is only accessible from the ground by a door in the aft cargo compartment and a set of doors in the airplane belly. The APU battery is located at floor level within the aft E/E bay.

²⁶ The plastic J3 connector provides battery power to the airplane, and the aluminum J1 connector provides signal information used by the BMU and the battery charger unit.

The APU battery installation location showed damage consistent with (1) heat generated from the APU battery and (2) smoke, hot gases, and electrolyte discharged from the battery, as shown in figure 5. Evidence of material expelled from the battery was seen in the areas behind the battery in the form of residue and thermal damage. The extent of thermal damage was confined to within about 20 inches from the battery installation. No primary structure (that is, those associated with airplane flight loads) was found damaged; secondary structure—specifically, the avionics rack²⁷ and the floor panel—exhibited thermal damage near where the APU battery had been installed.



Figure 5. Auxiliary power unit installation location with battery removed.

Examination of the area around the APU battery showed no signs of external electrical short circuits and/or other fire sources unrelated to the battery. The battery cables, which were routed up from an opening in the compartment floor, showed no chafes or short circuits to structure. The battery signal wires to and from the J1 connector were part of a wire bundle that showed evidence of thermal damage from interior and exterior heat.²⁸

The wire that was designed as the battery case ground wire (an intended electrical ground path) was significantly less damaged than the stainless steel sleeve around the signal wiring bundle (labeled W504014) that connected the BMU (in the battery case) to

²⁷ The avionics rack separated the APU battery from the battery charger unit.

²⁸ Interior heat was created by a current passing through the copper conductive core of the wire, affecting the interior of the insulation. Exterior heat includes any external source of heat that affected the insulation, including heat from a fire in the area that a wire passes through.

the avionics rack and then to the battery charger unit (BCU, discussed in section 1.6.1). The stainless steel sleeve and signal wires had damage consistent with excessive electrical current where they attached to the connectors at each end; at the battery case, the damage was also consistent with fire. As part of this investigation, the insulation of the battery case ground wire was cut open where the exterior was undamaged, and the internal surface was found slightly blackened, which was consistent with resistance heating associated with the flow of high levels of electrical current.

The aft E/E bay contains electrical cabinets (referred to as panels) that house components used to distribute electrical power from each engine and the APU. The panel labeled P49 is the source of electrical power distribution for the APU hot battery bus. No physical damage was noted to the P49 panel. When the circuit breakers on the P49 panel were disengaged, continuity checks of the circuit breakers, contactors, and battery cables to the BCU and battery electrical bus revealed no faults.

1.4 Flight Recorders

The airplane was equipped with forward and aft General Electric model EAFR 2100 enhanced airborne flight recorders (EAFR), which recorded cockpit voice recorder (CVR) audio data and FDR parametric data.²⁹ The forward and aft recorders were powered by the left and right 28-volt DC buses, respectively, and recorded the same set of flight data independently of each other. The forward recorder was equipped with an independent power supply to provide backup power to the recorder for about 10 minutes if the left 28-volt DC bus power was lost.

The CVR portion of the EAFR recorded 2 hours of audio data from the cockpit area microphone, the captain's audio selector panel/hot microphone, the first officer's audio selector panel/hot microphone, and the jumpseat/observer's position. The audio information from the forward recorder was used to produce a transcription summary that began at 0828:21, when the airplane was level in cruise flight at 39,000 feet, and ended at 1031:35, when the forward EAFR stopped recording.

According to the transcription summary for this incident, at 1021:41, the CVR recorded sounds associated with the APU shutting down; specifically, the cockpit fans stopped operating. Conversations among maintenance personnel and the turnaround coordinator about the APU shutdown began about 9 seconds later. At 1024:10, the turnaround coordinator reentered the cockpit and reported smoke in the cabin. No voices were heard on the CVR from 1024:22 to the end of the recording.

FDR data showed that, at 1021:01, a 1-volt decrease from the designed voltage of the APU battery (32 volts) was recorded. Three seconds later, the data showed a change

²⁹ Specifically, the EAFR is a multifunction recorder that records flight (FDR) data; audio (CVR) data; and communication, navigation, and surveillance air traffic management messages.

in current flow to 44 to 45 amperes into the battery. The battery voltage continued to decrease, and, at 1021:08, the current flow returned to 3 amperes out of the battery. At 1021:30, the battery voltage decreased to 28 volts, and the APU shut down 7 seconds later.³⁰ Table 2 shows selected events recorded before and after the APU shutdown. The FDR did not record any data indicating that the APU battery voltage had exceeded 32 volts.

Table 2. Events surrounding auxiliary power unit shutdown.

Time	Event
1000:24	Airplane touched down.
1004:10	APU started.
1006:15	Airplane completed turn into parking location.
1006:48	Parking brake set.
1006:52	Engine 1 shut down.
1006:54	Engine 2 shut down.
1021:01	APU battery bus voltage decreased from 32 to 31 volts.
1021:04	APU battery current increased to between 44 and 45 amperes for 4 seconds, indicating current flowing into the battery.
1021:07	APU battery bus voltage decreased to 30 volts.
1021:09	APU battery bus voltage decreased to 29 volts.
1021:10	APU battery bus voltage increased to 31 volts.
1021:15	EICAS message discrete indicated that the APU battery failed.
1021:27	APU battery bus voltage decreased 1 volt per second during the next 3 seconds until reaching 28 volts at 1021:30.
1021:37	APU battery bus voltage decreased to zero volts and returned to 28 volts three times, and APU battery current began to move between zero and -4 to -5 amperes, indicating current flowing out of the battery.
1021:37	APU controller went offline, and APU shut down.
1021:37	Aft EAFR stopped recording. Forward EAFR continued recording for about 9 minutes 58 seconds.
1021:40	EICAS message discrettes indicated that the left and right 1 and 2 AC buses became unpowered.
1021:41	EICAS message discrete showed that the APU battery failure was no longer indicated.
1022:00	EICAS message discrete indicated that the main battery was discharging.
1022:10	APU controller was back online.
1022:53	EICAS message discrete indicated that the main battery power switch was off.
1023:16	Airplane systems providing data to the EAFR had shut down.
1031:35	Forward EAFR stopped recording.

Note: EICAS, engine indicating and crew alerting system. The APU controller is the source of 32 recorded parameters, including APU shaft speed and APU battery bus voltage.

³⁰ Key parameters that showed the APU battery failure and APU shutdown are presented in figure 2 of the FDR Group Chairman’s factual report, which is available in the public docket for this incident.

1.5 Battery Examinations

1.5.1 External Observations

The APU battery was examined at the NTSB's materials laboratory in Washington, DC. Observations were documented using a numbering system designating the front of the battery (facing the external power connectors) as side 1, the left side as side 2, the back of the battery (facing the back wall of the aft E/E bay) as side 3, and the right side as side 4.³¹

Side 1 of the battery case exhibited black residue and white powdery material on the exterior surface, which were consistent with the flames reported at the J1 and J3 connectors and the application of a dry chemical fire-extinguishing agent by the JAL mechanic. Additionally, on the lower edge of side 1, there was damage caused by a prying tool used by ARFF personnel in their efforts to remove the battery from the airplane. Side 2 of the battery case appeared to have the least visible damage of the four battery sides, with some soot residue observed and an area of bulking and a missing battery case attachment bracket associated with the battery's removal from the airplane. Sides 1 and 2 of the battery case are shown in figures 6 and 7, respectively.



Figure 6. Side 1 (forward face) of the battery case.

³¹ When facing aft in the airplane, the left and right sides of the battery correspond with the left and right sides of the airplane.



Figure 7. Side 2 (left side) of the battery case.

Side 3 of the battery case appeared to be minimally damaged near side 2 but was more heavily damaged near side 4. Vertical black streaks, which were consistent with residue from dripping liquid, were observed toward side 4 in a location that corresponded to the damaged corner of the battery lid. A roughly oval deposit of black residue covered the side 3 upper face near the side 4 edge. Side 3 had a mostly circular distortion—a paint discoloration about 1 inch in diameter with a 0.25-inch-wide nodular protrusion in the middle—near the lower corner adjoining sides 3 and 4. The protrusion was located about 1.5 inches from the bottom and 1.5 inches from the left edge. Side 3 of the battery case is shown in figure 8.



Figure 8. Side 3 (aft face) of the battery case.

Side 4 of the battery case appeared to have the most extensive damage of the four battery sides. The exterior was heavily coated with black residue that was concentrated near side 3. Thicker black deposits were visible on the right side near the battery lid. Large, mostly circular areas of thermal damage to the paint were located at the same elevation as the battery cell vent discs,³² as viewed from the exterior. A distortion and an area of missing paint were adjacent to and opposite of the cell 7 vent disc. An area of thermal damage to the paint was adjacent to and opposite the cell 6 vent disc. In both of these vent disc locations, the black residue that remained had a different appearance than the surrounding residue. For the cell 7 vent disc location, the soot and paint had disbonded, leaving a relatively concentric appearance. Paint discolorations were also visible at the cell 5 and 8 locations. The battery case attachment bracket was missing from this side, which was consistent with the removal of the battery from the airplane by ARFF personnel. Side 4 of the battery case is shown in figure 9.

³² A vent disc is a plate that ruptures when the internal pressure in a cell reaches a predetermined level. The battery was configured with the vent disc for each cell oriented toward the exterior of the battery.



Figure 9. Side 4 (right side) of the battery case.

The lid on the battery case was bulged and creased. The corners of the lid, which were designed to butt up to each other, had spread as a result of bulging and deformation of the lid, leaving a small gap. The right rear lid corner (as viewed from the front of the battery case) exhibited more soot, charring, and residue than the rest of the lid. Most of the lid gasket was consumed.

Eight mounting tabs are used to attach the battery lid to the battery case, and screws are used to fasten the mounting tabs. The two mounting tabs on side 1 remained engaged with the screws. The mounting tabs on sides 2 through 4 had torn from the fastening screws by gross deformation and overstress. The torn mounting tabs and their fracture surfaces exhibited deposits consistent with breakage during the battery failure.

1.5.2 Battery Disassembly

The battery was disassembled so that the internal components could be examined. Side 2 of the battery case was folded down to reveal cells 1 through 4, as shown in figure 10. The insulation sheet remained in place adjacent to the battery cells. Behind the insulation, a portion of the insulation sheet was visible but was missing some sections. Although the insulation between cells 1 through 4 was damaged, the material was distinguishable from other thermally damaged material in the battery case. The interior surface of folded-down side 2 had a clean area with a similar outline to that of the insulation sheet. The rest of the interior surface of side 2 was coated with residue.

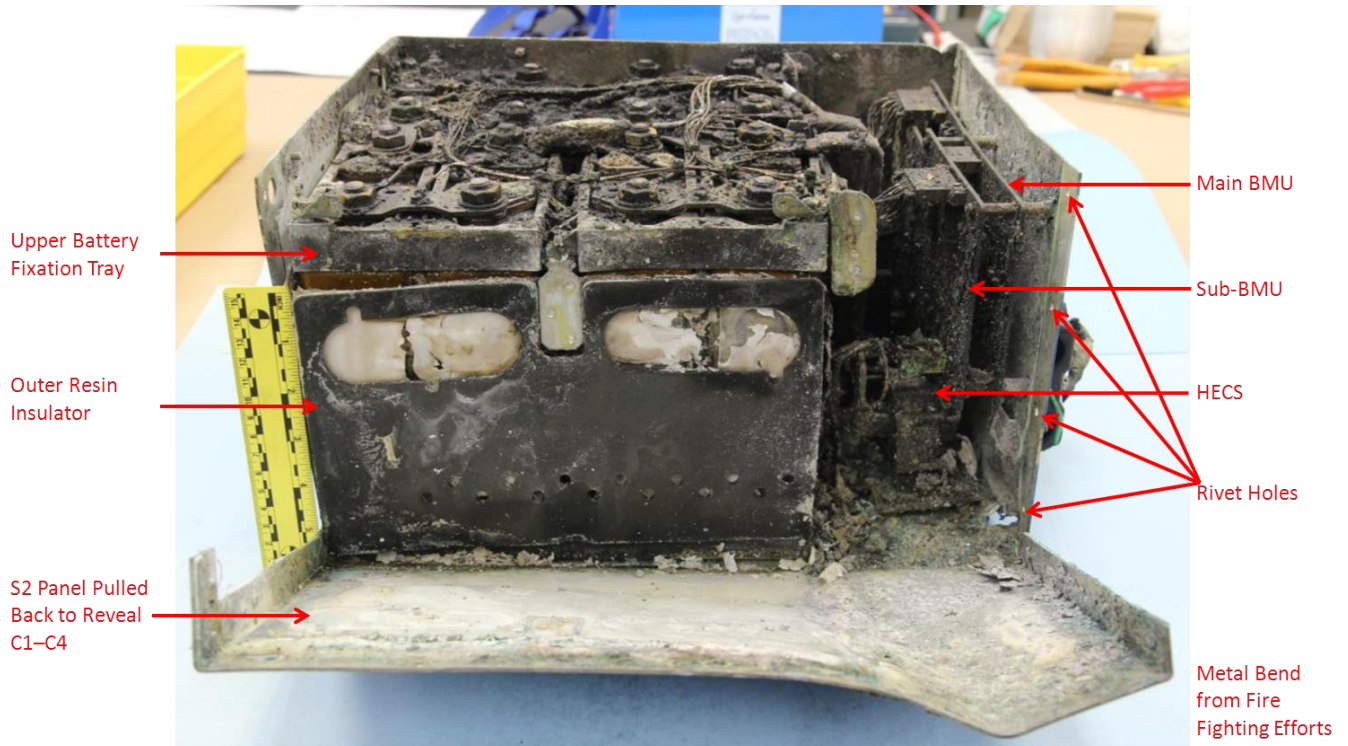

Figure 10. Battery case with side 2 folded down.

Battery case side 4 was folded down to reveal the position of cells 5 through 8, as shown in figure 11. The cells exhibited a darkened, charred appearance. The insulation sheets were completely charred and were indistinguishable from each other and other thermally damaged material in the battery case, and portions of the charred insulation adhered to the cells. The interior surface of folded-down side 4 had portions of the charred insulation adhering to areas where the insulation sheets contacted the interior surface. The rest of the interior surface of side 4 was coated with residue.

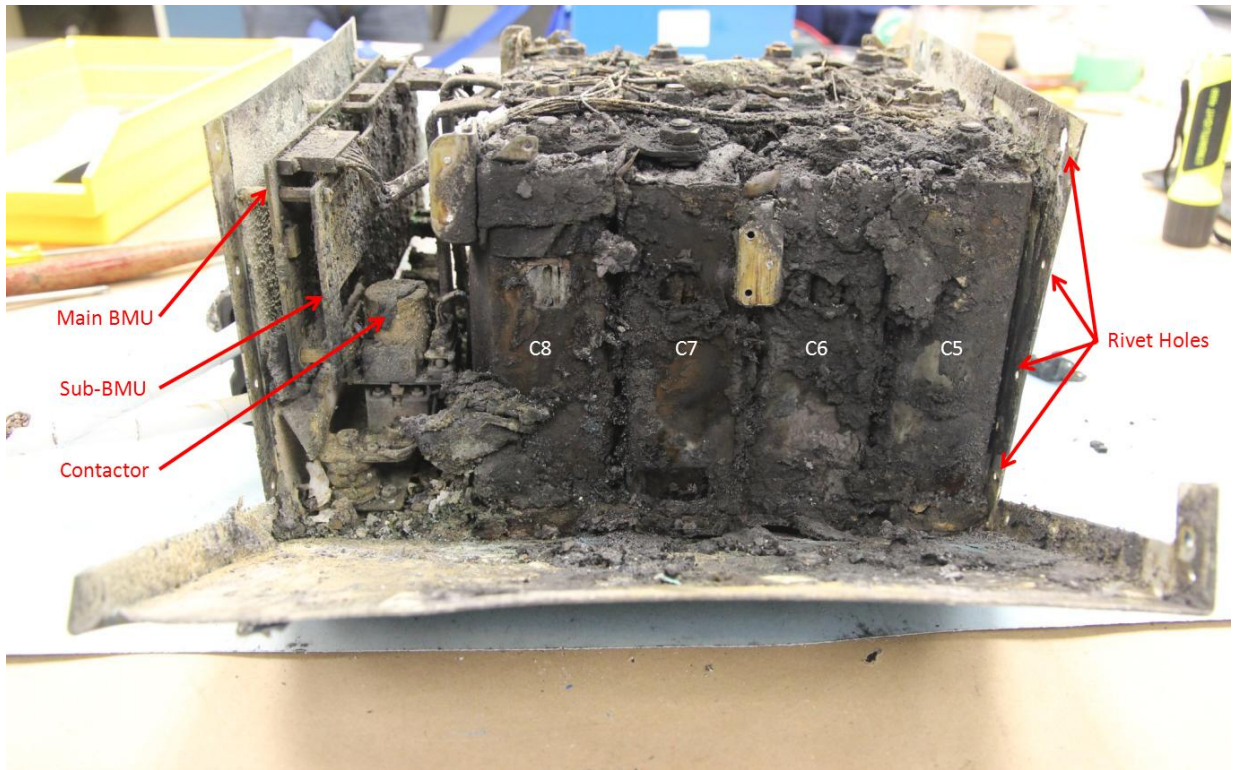

Figure 11. Battery case with side 4 folded down.

Side 3 of the battery case was folded down to reveal the sides of cells 4 and 5, as shown in figure 12. The side of cell 4 had staining that resembled a flowing residue. The side of cell 5 had similar staining but also had a clean area on the cell case. The corresponding area on the interior surface of folded-down side 3 had large portions of insulation adhering to it. The insulation along side 3 was thermally degraded and fragmented, and the portions of the insulation adhering to the battery case directly behind cell 5 exhibited some thinning. The damage in the area of the nodular protrusion that was observed on the side 3 battery case corresponded with damage to the cell 5 case, as discussed in section 1.5.3.

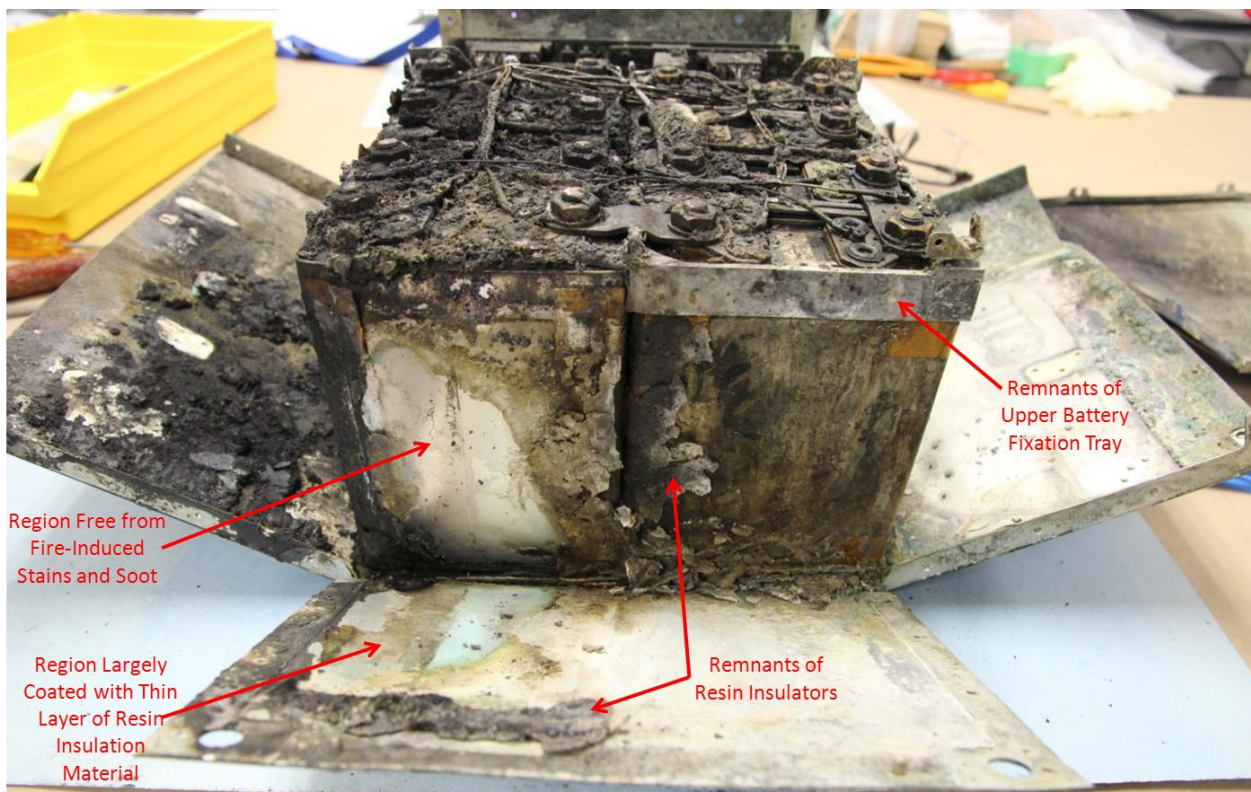

Figure 12. Battery case with side 3 folded down.

The battery cells exhibiting the least thermal and mechanical damage were cells 1 through 4, which were located along the left side of the battery assembly. Of these cells, cell 3 appeared to be the most thermally damaged. Cells 1 through 3 had vented (that is, their vent discs had opened slightly), but the cell 4 vent disc remained intact, although weight measurements indicated that the cell lost some electrolyte. The battery cells exhibiting the most thermal and mechanical damage were cells 5 through 8, which were located along the right side of the battery assembly. The thermal damage was indicated by thermal decomposition and degradation of the materials in contact with these cells. These materials included bisphenol A (commonly referred to as BPA) thermoplastic polyester, which decomposes at a temperature of about 550° F, and sulfide crystalline thermoplastic, which decomposes at a temperature of about 545° F. Thermal damage was the most severe near cell 6, as shown in figure 13. The vent discs on cells 5 through 8 had ruptured in a manner indicative of a rapid pressure release.³³ Cells 5 through 8 had sustained gross mechanical plastic deformation with cells pressing into neighboring cells.

³³ The vent discs are scored with an “x” pattern, which enables preferential tearing when the disc ruptures, creating four independent petals. For the vent discs on cells 1 through 3, the four petals had slightly parted but remained in the same plane. For the vent discs on cells 5 through 8, the four petals were splayed out and positioned out of plane with the discs’ original position, which was indicative of a more forceful opening.

Continuity measurements using a digital volt meter indicated that all of the cells were found to be electrically short circuited except for cell 8.

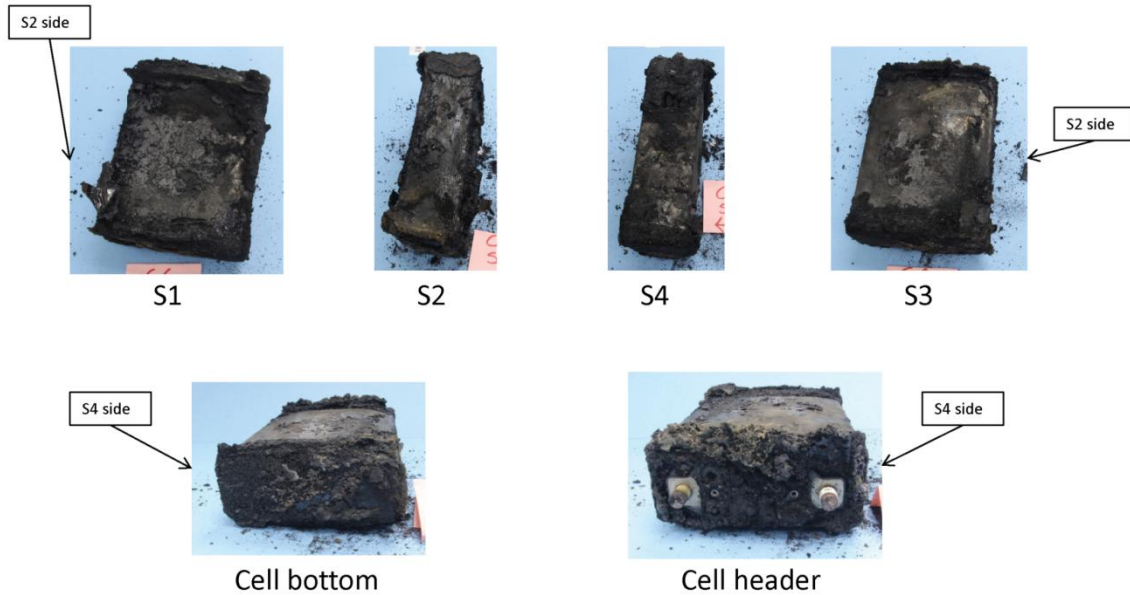

Figure 13. Views of cell 6.

The bus bars were removed from the cells to allow extraction of the battery cells. The contact surfaces of the bus bars were evaluated. No indications of localized resistive heating or arcing were observed on the contact surfaces.

Debris and discoloration consistent with thermal damage was present on the cell 1 through 4 footprints on the bottom fixation tray. The footprints of cells 5 through 8 were thermally decomposed. Portions of the bottom fixation tray under cells 5 and 6 were not readily distinguishable from other thermally damaged materials in the battery case. The portions of the top fixation tray that contacted cells 1 through 4 sustained less damage than the portions that contacted cells 5 through 8. The cell 4 imprint remained mostly intact, but the imprints for cells 1 through 3 showed progressively more damage. Minimal material remained from the portions of the top fixation tray that contacted cells 5 through 8.

The J3 connector and receptacle were also examined. The J3 connector had dark deposits on one of the blades of the positive junction (terminal), and the other blades appeared clean with no deposits, stains, or discoloration. Analysis of the dark deposits revealed the presence of an aliphatic hydrocarbon. The blades on the negative junction of the connector appeared clean with no deposits, stains, or discoloration. The J3 receptacle had thermally induced deformation on one corner. The terminals on the receptacle showed no indications of deposits, stains, or discoloration.

1.5.3 Battery Case Protrusion and Corresponding Cell Case Damage

As previously stated, the battery case exhibited a 0.25-inch-wide nodular protrusion on the lower left of side 3, as shown in figure 14. The protrusion extended about 0.12 inch from the case. Two concentric rings surrounding the protrusion corresponded with the discoloration of the exterior paint. (The protrusion appeared metallic and was absent of paint.) Deposits consistent with thermally degraded materials were observed on and near the protrusion, and at least three holes in the battery case and on the periphery of the protrusion were identified. The largest of these holes was elliptical in shape, with its longest dimension measuring 0.080 inch. The two other holes, which were similar in size, measured about 0.004 inch. Most of the interior side of the protrusion contained dull gray flakey material that was consistent with spatter and shiny black material that was consistent with charred plastics and tars.



Figure 14. Protrusion on the lower left of battery cases side 3.

The side of the cell 5 case that faced side 3 of the battery case had been heavily damaged, especially on its periphery. Four holes measuring between 0.005 and 0.050 inch were identified on the lower portions of this side of the cell case, all of which exhibited large amounts of dark, rough-appearing features consistent with decomposition products. The largest hole (in terms of size and amount of decomposition products) corresponded with the location of the protrusion on the battery case.

The protrusion was inspected using a scanning electron microscope (SEM) and energy dispersive x-ray spectroscopy (EDS). The inspections determined that arc damage occurred from contact between the cell 5 case and the battery case.³⁴ Evidence of material transfer between the cases was only found on the interior surface of the battery case and exterior surface of the cell case. The case for cell 5 is located about 0.2 inch from the battery case. The battery case exhibited no inward deformation at the protrusion, whereas the cell case exhibited outward expansion. These features are indicative of arc damage between the cases after expansion of cell 5. SEM and EDS inspections also showed that all the holes on the cell 5 case exhibited various compounds and alloys that were not part of the cell case material, and inspection by EDS showed that this material was consistent with the battery case material.

1.5.4 Radiographic Examinations

The NTSB conducted radiographic examinations on January 11 and 12, 2013, and January 18 through 22, 2013, at Chesapeake Testing in Belcamp, Maryland, to examine and document the internal configuration of the 787 main and APU batteries and six of the eight APU battery cells installed on the incident airplane.³⁵ The batteries were documented using x-ray computed tomography (CT) scans and digital radiography, and the battery cells were documented using CT scans. The images of the components were examined for signs of missing or damaged parts, contamination, or other anomalies.

The CT scans for the main battery showed no anomalies outside the cells. The CT scans for the APU battery showed that (1) several cells were distorted and had an expanded or contracted profile, (2) several current collectors inside the cells were separated, (3) some current collector fingers were out of their designed alignment,³⁶ and (4) a breach of the battery case corresponded with a breach of the cell wall in cell 5. A CT scan of the APU battery is shown in figure 15.

³⁴ The other seven cells did not exhibit any evidence of electrical arcing on the exterior of the cells.

³⁵ The main battery was used as an exemplar battery for the radiographic studies.

³⁶ Two sets of current collectors are in each battery cell. One set is aluminum (cathode), and the other set is copper (anode). The current collectors attach to the cell windings and conduct the current to the terminals. The fingers on the current collectors are the link between the windings and the terminals.

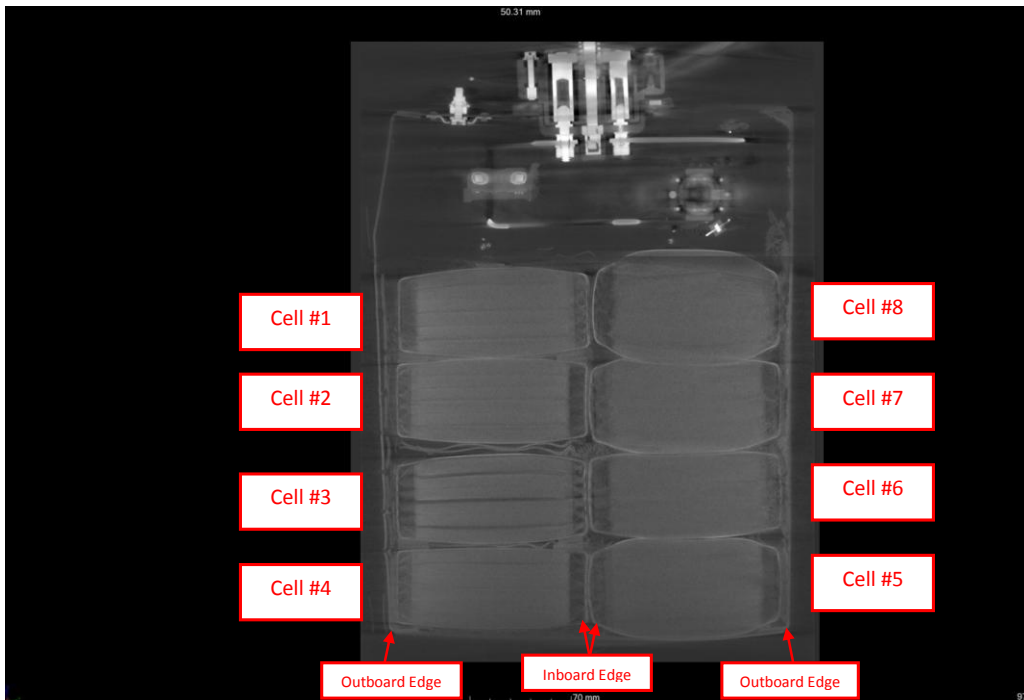

Figure 15. Cross-sectional view of the auxiliary power unit battery.

The six individual APU battery cells that were examined were cells 1 and 3 through 7. The CT scans for cells 1 and 3 showed that the cells did not have any breaks in the current collectors, but the cells were swollen, and there were a number of areas where the uniformity of the windings was disturbed. Numerous higher density particles were also noted in and around the electrode assembly in these cells. The CT scans for cell 4 showed that the cell was not swollen and did not have separations within the winding layers.

The CT scans for cell 5 showed the following:

- There were two cell wall breaches in separate locations identified during the radiographic examination.³⁷ The larger of the two breaches appeared to consist of separate smaller holes, as shown in figure 16. The smaller breach appeared to consist of a single hole with some material missing from the outer cell wall around the hole. There were some anomalies inside the cell near the breaches; these areas differed from the general appearance of the cell.

³⁷ In addition to these two holes, two other holes were identified during the SEM inspection, as discussed in the previous section.

- Two of the six aluminum (cathode) current collector fingers had breaks that appeared to have rounded material on the ends. The breaks also appeared to go all the way through the fingers. The copper (anode) current collectors were intact.
- Some high-density areas were noted within the electrode assembly generally along the edges and next to the cell wall.

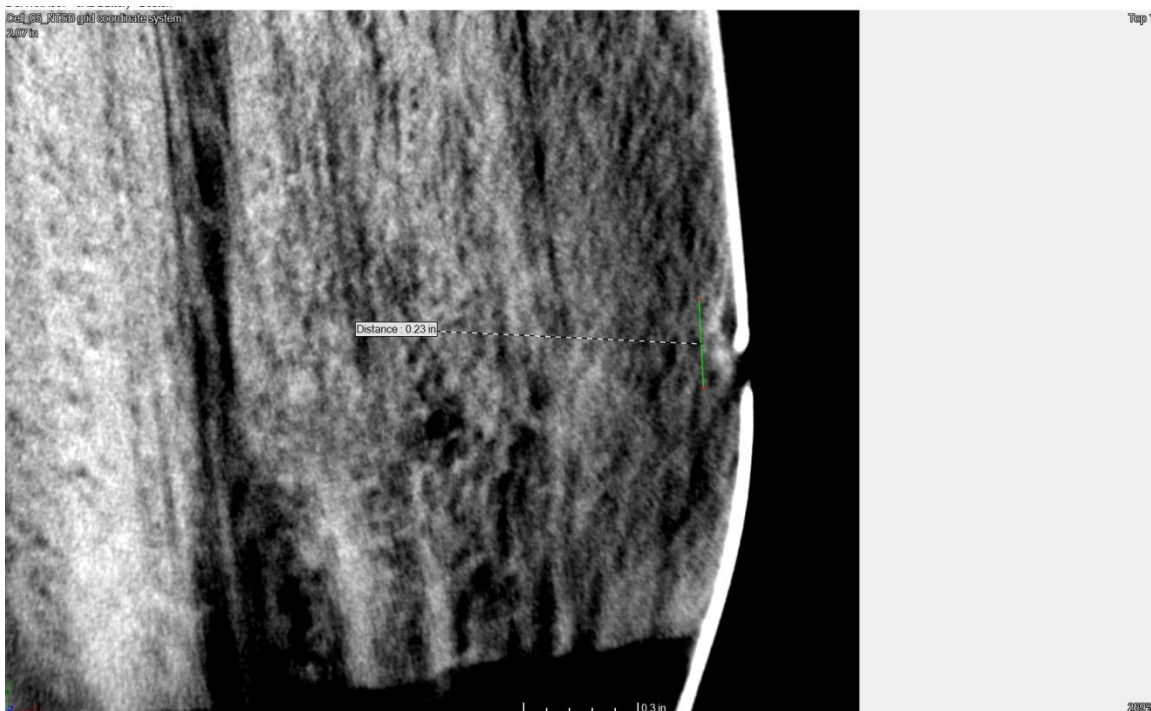

Figure 16. Top view of cell 5 showing cell wall breach.

The CT scans for cell 6 showed no breaches in the cell wall. Other results included the following:

- Four of the six aluminum (cathode) current collector fingers had breaks, as shown in figure 17, including one that had multiple breaks and one that was missing more material in its break than the other current collector fingers with breaks. The gap in missing material measured about 0.15 inch. The copper (anode) current collectors were intact.
- There were a number of locations where a lump of medium-radiodensity material appeared to have flowed outside of the electrode assembly. In general, a small ribbon of material connected the lump with the rest of the electrode assembly.

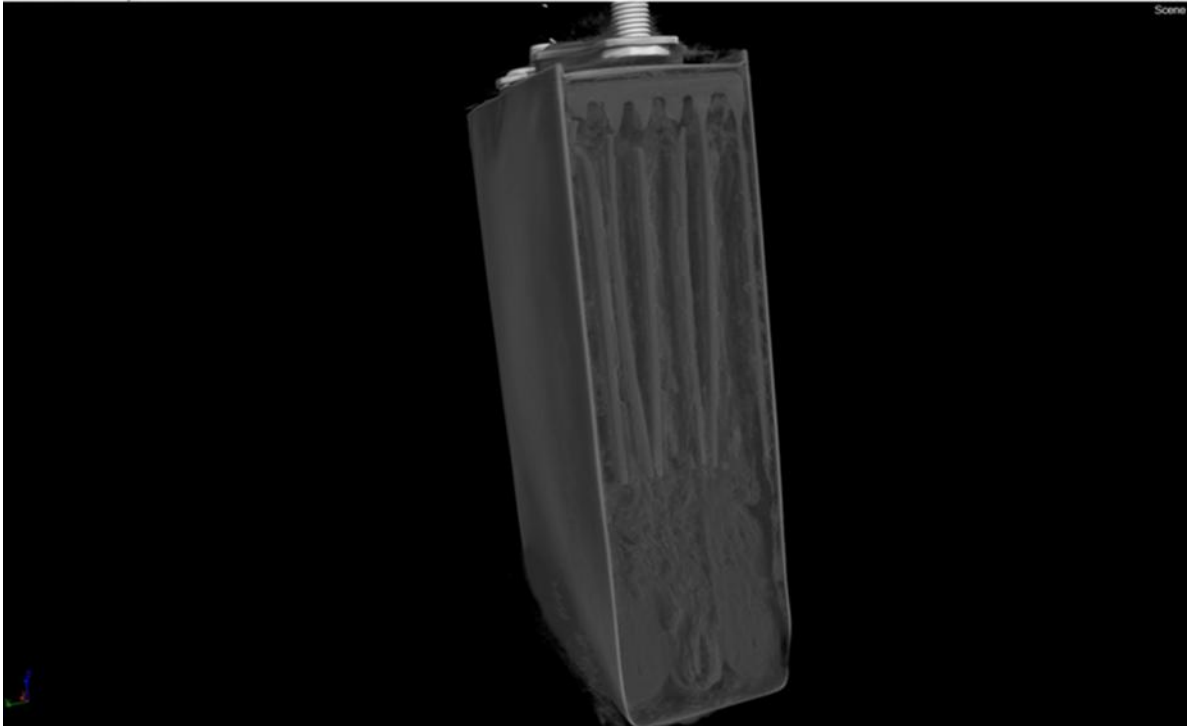

Figure 17. Three-dimensional view of aluminum current collectors in cell 6.

The CT scans for cell 7 showed no breaches in the cell wall. Other results included the following:

- A possible low-radiodensity area was noted at the top of the cell between the electrodes, and a distinct high-radiodensity region was noted in the cell wall.
- Four of the six aluminum (cathode) current collector fingers had breaks, including one that had multiple breaks. All six fingers appeared to be displaced from their original positions. The copper (anode) current collectors were intact.
- There were some variations in the appearance of the electrode assembly throughout the cell. In particular, the electrode assembly in one location appeared to be more granular than other areas in the cell, as shown in figure 18.

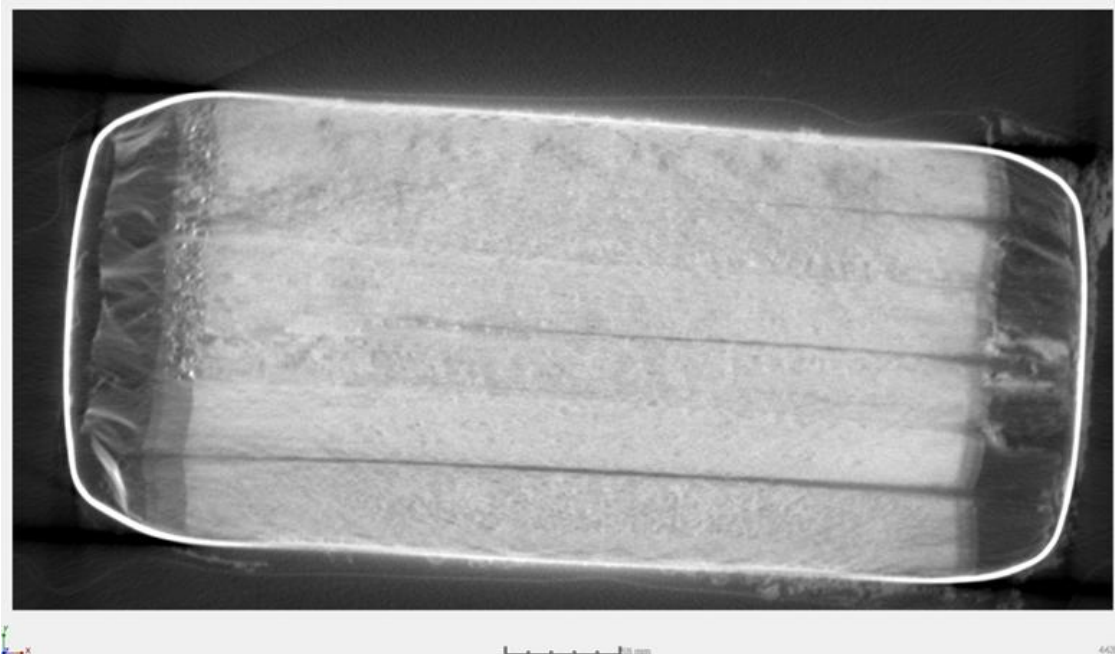

Figure 18. Granularity noted in top view of cell 7.

1.6 Component Testing

1.6.1 Battery Charger Unit

The BCU for the APU battery was manufactured by Securaplane Technologies in June 2012. The BCU includes an electric connector for communication (among the BCU, battery, and airplane), a ground wire stud, and power terminals for the two large battery cables. Another BCU is used on the main battery installation.

The BCU was examined at Securaplane's facility in Tucson, Arizona, on January 22 and 23, 2013. The resistance of each pin in the J1 connector was measured to ground, and the results did not reveal any anomalies. Also, no anomalies were found during a visual inspection of the BCU internal components.

The BCU was connected to test equipment, and an acceptance test procedure (ATP) was performed according to Thales and Securaplane reference documents.³⁸ The BCU passed all performed portions of the ATP except for one test, which was designed to verify that the BCU would not send out a battery charging current if input from the

³⁸ The bonding resistance tests in the ATP were not performed because of the presence of a light-colored film (residue from firefighting activities) on the top and front surfaces of the BCU external case.

BMU indicated that the battery temperature was less than 5° F ($\pm 2.7^\circ$ F). Testing showed that the BCU inhibited battery charging at a battery temperature of 8.4° F, which was 0.7° F warmer than the required temperature with the maximum tolerance (7.7° F).

1.6.2 Start Power Unit

The start power unit (SPU) was manufactured by Securaplane Technologies in September 2012. The SPU converts DC battery power to AC power for starting the APU and provides excitation power for the APU during startup. The SPU includes a connector plug, power output port, and three input power terminals.

The SPU was examined at Securaplane's facility on January 22 and 23, 2013. The connector plug pins and power connections appeared to be in good condition. The SPU was connected to test equipment, and an ATP was performed according to a Thales/Securaplane reference document.³⁹ The SPU passed all performed portions of the ATP except for the low-load operational test, which was not part of the ATP when the SPU from the incident airplane was manufactured. The low-load operational test was added to the ATP to test an extreme condition in which the SPU is required to supply excitation power to the starter generator at the high limit of input voltage. The incident SPU stopped supplying power during this test.

1.6.3 Battery Monitoring Unit

The BMU is a subassembly that is mounted in the battery case. The BMU includes a main circuit card and a sub-circuit card, each of which contains two independent monitoring systems: BMU1 and BMU2 (main circuit card) and BMU3 and BMU4 (sub-circuit card). Each of the four BMU systems has an initiated built-in test function. The main circuit card and sub-circuit card installed on the incident airplane were manufactured by Kanto Aircraft Instrument Company (KAI), Ltd., in March and April 2012, respectively.

BMU1 monitors for cell overcharge, overdischarge, overheating, and imbalance; controls the cell balancing function when any cell reaches a predetermined threshold; and is the source of voltage for the BCU. BMU2 provides a redundant monitor for cell overcharge. BMU3 controls the contactor and provides additional monitoring for battery and cell overcharge. BMU4 monitors for cell overdischarge and high current charge. If any of the battery monitoring thresholds were exceeded, the BMU was designed to send a signal to the BCU to discontinue charging. The BMU main circuit card and sub-circuit card do not contain nonvolatile memory (NVM), and none of the BMU data are recorded on the FDR.

³⁹ The isolation test in the ATP was not performed because of the presence of a light-colored film (residue from firefighting activities) on the SPU case.

An x-ray examination of the circuit cards and wiring harnesses was performed on January 18, 2013, in the NTSB's materials laboratory in Washington, DC. During the x-ray examination, damage was observed on three of the BMU sub-circuit card components. Component testing was conducted on January 22 and 23, 2013, at the manufacturer's facility in Fujisawa, Kanagawa, Japan.

The BMU main circuit card and sub-circuit card were visually inspected before functional testing began. The visual inspections found thermal damage to various components, including the printed wiring boards⁴⁰; the damage to the BMU main board is shown in figure 19. The thermal damage precluded the ATP from being performed. (The ATPs for the BMU main circuit card and sub-circuit card were completed successfully during the manufacturing process in May and June 2012, respectively.)

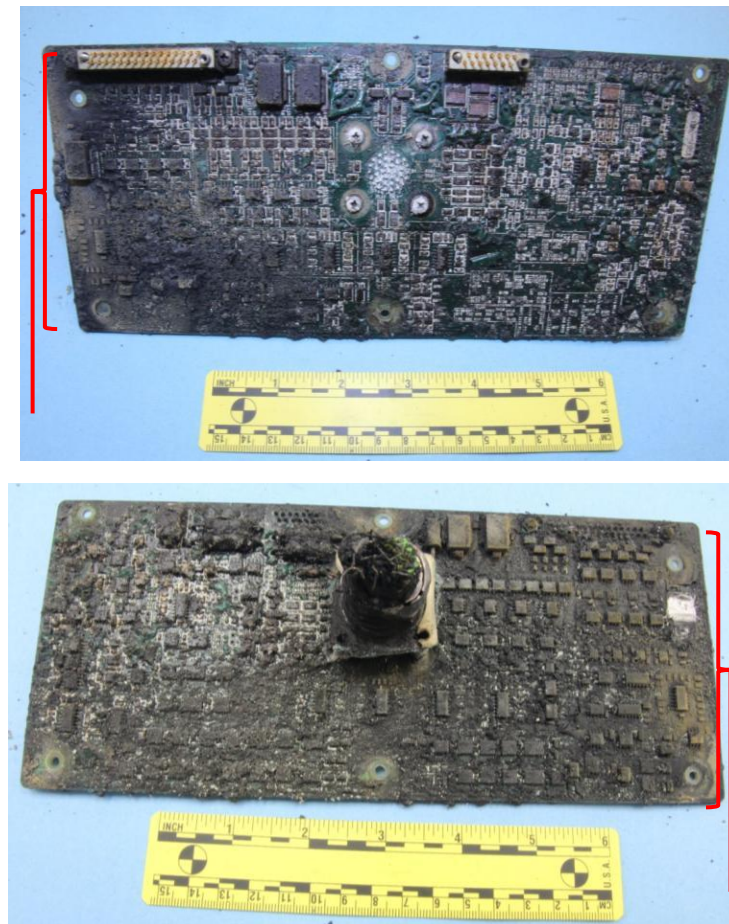

Figure 19. Battery monitoring unit main board.

Note: The top photograph shows the side of the board facing the interior of the battery case, and the bottom photograph shows the side facing the exterior of the case.

⁴⁰ Exposure to fire released the solder that attached components to the circuit boards, exposing the subsurface layers of the circuit boards.

One of the transient voltage suppressors mounted on the main BMU circuit card was found detached from the circuit card. (A transient voltage suppressor is designed to protect an electronic circuit from a sudden or momentary overvoltage condition.) The BMU and suppressor had passed manufacturing quality tests and would have logged a failure if the suppressor had detached before the incident. The melting point of the solder (which attached components to the circuit board) was below that of the maximum heat within the battery during the incident. The two suppressors that were part of the circuit containing the detached suppressor were functionally checked on test equipment using a multimeter, and the components measured nominally. The suppressor that was found detached was further tested using a variable DC power supply, and the component operated per specification.

In addition, functional tests were performed on two BMU sub-circuit card thermoprotectors, which are used in battery protection circuits on BMU4 for overdischarge or reverse current. The thermoprotector tests were conducted using a multimeter and x-ray examination, and both circuits were determined to be open. The temperature at which a circuit opens to protect the component is $268^{\circ}\text{F} \pm 5.4^{\circ}\text{F}$.

Power was not applied to the printed wiring board in the BMU main circuit card and sub-circuit card because of the heat-related damage to the board components and the circuit cards. Individual circuits that did not require circuit board power were tested, and each of the tested circuits in the main BMU circuit card matched expected design values. For the BMU sub-circuit card, the circuit containing an electromagnetic filter (BMU3) did not pass a circuit measurement test. Impedance checks performed for each battery cell voltage circuit were lower than expected compared with the results from an exemplar BMU sub-circuit card. All of the remaining tested circuits in the BMU sub-circuit card matched expected design values.

1.6.4 Contactor

The contactor is a device that can electrically separate the battery cells from the charger and battery bus. It is mounted in the bottom of the battery case near the BMU and is normally closed. The contactor can only be commanded to open by BMU4 if a cell overdischarge or high charge is detected.

The contactor was manufactured by Zodiac Aerospace of France in March 2012. The contactor was examined at the manufacturer's facility in Niort, France, on February 6 and 7, 2013. The examination found that the fire and exposure to burning materials within the battery case resulted in high temperature exposure (estimated to be above 570°F). Fire-related foreign material deposits were found inside and outside of the contactor case. The damage to the contactor precluded a full functional test from being performed.

The main contacts were found in the de-energized (closed) state, and measurements found that the contact pressure was within a nominal range. The faces of

the contacts were in good condition and exhibited normal wear and arcing marks but no evidence of having been welded together. The auxiliary contacts were also found in the de-energized state. The measured resistance of each coil inside the contactor case was within specification tolerances.

1.6.5 Auxiliary Power Unit Controller

The APU controller operates the valves, motors, and sensors that control the operation of the APU and contains NVM to record various APU parameters. The APU controller on the 787 is located near the bulk cargo door and is separate from the APU battery. The APU controller was manufactured by Hamilton Sundstrand in November 2011.⁴¹

The APU controller was examined at UTC Aerospace Systems in Phoenix, Arizona, on January 24, 2013. The APU controller was connected to test equipment to download the NVM from the unit. A review of the NVM data found that eight messages associated with the APU shutdown were recorded during the event timeframe. The APU controller passed all sections of the ATP.

1.7 System Safety and Certification

As part of its investigation of this incident, the NTSB is reviewing the *Federal Aviation Regulations* and special conditions applicable to the 787 main and APU battery and battery charger system. The NTSB is also reviewing the corresponding certification plan, which was developed by Boeing and approved by the FAA. The plan defined the agreed-upon methods to be used to demonstrate that the battery and its charger system met applicable FAA and European Aviation Safety Agency (EASA) requirements.⁴² In addition, the NTSB is reviewing sections of Boeing's 787-8 electrical power system safety assessment document that pertained to the main and APU battery. Boeing developed this safety assessment to evaluate the design of the electrical power system for compliance with safety requirements defined by the FAA and EASA.

1.7.1 Type Certification and Battery Special Conditions

On March 28, 2003, Boeing applied for a type certificate for the 787-8 airplane. According to the type certificate data sheet, the 787-8 airplane received transport-category approval on August 26, 2011. The applicable certification basis included the 14 CFR Part 25 airworthiness standards and special conditions for the

⁴¹ Hamilton Sundstrand merged with another company in 2012 to form UTC Aerospace Systems.

⁴² The 787-8 FAA certification was also validated by EASA.

lithium-ion battery installation.⁴³ Certification oversight and approval for the 787 was conducted by the FAA's aircraft certification office in Seattle, Washington.

In a notice of proposed special conditions (72 *Federal Register* 21162, April 30, 2007), the FAA indicated that the 787 design included the planned use of lithium-ion batteries for the main and APU battery.⁴⁴ The FAA stated that lithium-ion batteries were "a novel or unusual design feature" for transport-category airplanes and that there was limited experience with the use of lithium-ion batteries in applications involving commercial aviation. The FAA pointed out that other users of lithium-ion batteries, including wireless telephone manufacturers and electric vehicle manufacturers, have experienced safety problems, including overcharging, overdischarging, and flammability of cell components.

The FAA indicated that lithium-ion batteries have "certain failure, operational, and maintenance characteristics that differ significantly from those...batteries currently approved for installation" on large transport-category airplanes. In particular, the FAA noted that lithium-ion batteries are "significantly more susceptible to internal failures that can result in self-sustaining increases in temperature and pressure (thermal runaway)" than nickel-cadmium or lead-acid batteries.

The FAA believed that the applicable airworthiness regulations for 787 type certification did not contain adequate or appropriate safety standards for lithium-ion batteries. As a result, the FAA issued final special conditions for the 787 lithium-ion battery installation (25-359-SC, 72 *Federal Register* 57842, October 11, 2007) that became effective on November 13, 2007.⁴⁵ These special conditions were intended to ensure that this new technology would not pose a greater safety risk than other technologies addressed in existing airworthiness regulations. The nine special conditions are detailed in the appendix.

⁴³ The applicable regulations were 14 CFR Part 25 through amendment 25-119 and amendments 25-120, 25-124, 25-125, and 25-128 (with exceptions). Other applicable regulations were 14 CFR Part 26, Continued Airworthiness and Safety Improvements for Transport Category Airplanes; 14 CFR Part 34, Fuel Venting and Exhaust Emission Requirements for Turbine Engine Powered Airplanes; 14 CFR Part 36, Noise Standards: Aircraft Type and Airworthiness Certification; equivalent level of safety references; and special conditions for 13 other subjects.

⁴⁴ Lithium-ion batteries were also used in flight control electronics, the emergency lighting system, and the recorder independent power supply.

⁴⁵ The final special conditions document indicated that, in response to the FAA's notice of proposed special conditions, the Air Line Pilots Association (ALPA) provided comments. According to the document, ALPA "conditionally supports the FAA's proposal for special conditions for lithium ion batteries on the 787 aircraft, but 'strongly maintains that there need to be adequate protections and procedures in place to ensure that concerns regarding lithium ion batteries are fully addressed and protected against.'" ALPA also asked the FAA to consider specific concerns, as detailed in the final special conditions document.

1.7.2 Certification Plan

Boeing developed the 787 electrical power system certification plan and obtained FAA approval of the original plan on December 22, 2005. The certification plan presented a high-level system description of the electrical power systems, which included the main and APU battery and battery charger; defined the methods to be used to show compliance with applicable FAA and EASA requirements; and defined the compliance submittals to be provided to the agencies. As part of the certification plan, Boeing conducted tests and analyses and presented the results of this work, which were approved by a Boeing authorized representative and accepted by the FAA, to demonstrate compliance with the following 14 CFR Part 25 requirements:

- Subpart D, Design and Construction
 - 25.601, General
 - 25.611, Accessibility Provisions
 - 25.863, Flammable Fluid Fire Protection, paragraphs (a) and (b)(3)
- Subpart F, Equipment
 - 25.1301, Function and Installation, paragraphs (a) and (d)
 - 25.1309, Equipment, Systems, and Installations, paragraphs (a), (b)(1), (b)(2), and (c) through (g)
 - 25.1431, Electronic Equipment, paragraph (a)
- Appendix K, Extended Operations, paragraph K25.1.1
- Special Conditions 25-359-SC

1.7.3 System Safety Assessment

Safety assessments are a primary means of compliance for systems that are critical to safe flight and operation. Safety assessments proceed in a stepwise, data-driven manner. Functional hazard assessments are performed to identify the failure conditions associated with each airplane function, and system functional hazard analyses are performed for system-level functions. The bottom-up verification starts with a safety analysis of the components of a system to ensure that single failures do not result in significant effects. Combinations of failures are then analyzed to develop the probability of a failure and checked to ensure that the probability is commensurate with the criticality

of the failure condition. Thus, the final definition and characterization of a safety-critical system is verified by the result of the analyses conducted during a safety assessment.

Boeing performed a functional hazard assessment as part of the 787 electrical power system safety assessment to determine the potential hazards that various failures of electrical system components could introduce to the airplane and its occupants. The functional hazard assessment identified and classified two hazards associated with the main and APU lithium-ion battery: “battery vents smoke/fire,” which was classified as catastrophic,⁴⁶ and “battery vent and/or smoke (without fire),” which was classified as hazardous.⁴⁷ On the basis of the results of the functional hazard assessment, Boeing defined three failure requirements for the main and APU lithium-ion battery, as shown in table 3.

Table 3. Battery safety requirements.

Requirement number	Description
1	The battery shall have a probability of less than 1×10^{-7} for gas emission.
2	The battery shall have a probability of less than 1×10^{-7} for smoke emission.
3	The battery shall be designed to prevent spilling flammable fluid, a hazardous event with occurrence with a probability of less than 10^{-9} .

Boeing’s 787-8 electrical power system safety assessment also included an analysis of lithium-ion battery cell failure modes. This analysis determined that overcharging was the only known failure mode that could result in cell venting with fire. As a result, Boeing established additional design requirements to ensure that the likelihood of occurrence of an overcharge event was extremely improbable.⁴⁸ Boeing further determined that cell venting without fire could be initiated by several different failure modes, including external overheating, external short circuiting of appropriate impedance, internal short circuiting, recharging a battery that has been overdischarged, high-rate charging, or charging at cold temperatures. To evaluate the effect of cell venting resulting from an internal short circuit, Boeing performed testing that involved puncturing a cell with a nail to induce an internal short circuit. This test resulted in cell venting with smoke but no fire. In addition, to assess the likelihood of occurrence of cell venting, Boeing acquired information from other companies about their experience using

⁴⁶ The harmonized requirements for 14 CFR Part 25.1309 define a catastrophic event as one that normally involves a hull loss with multiple fatalities and is assigned an allowable qualitative probability of being extremely improbable and an average quantitative probability of less than 1×10^{-9} per flight hour.

⁴⁷ The harmonized requirements for 14 CFR Part 25.1309 define a hazardous event as one that normally involves a large reduction in functional capability or safety margins of the airplane with serious or fatal injury to a small number of passengers or cabin crew along with physical distress or excessive workload impairing the ability of the flight crew and is assigned an allowable qualitative probability of being extremely remote and an average quantitative probability of less than 1×10^{-7} per flight hour.

⁴⁸ The risk of fire was addressed through overcharge protections. For example, Boeing required that “the battery monitoring unit when combined with the overall battery protection subsystem shall prevent undetected over-charge (over-voltage) a catastrophic event with a probability of occurrence of less than 1×10^{-9} .”

similar lithium-ion battery cells. On the basis of this information, Boeing assessed that the likelihood of occurrence of cell venting would be about one in 10 million flight hours.

Boeing used the results of its analysis and tests to incorporate several safety features inside and outside of the battery that were designed to prevent the conditions of cell venting and cell venting with fire. These features included thermal protection devices, circuitry to monitor cell and battery voltages and temperatures, circuits to ensure that all cells in a battery are charged equally and within safe voltage limits, and components and circuitry that discontinue charging of the battery when conditions warrant this action.

Overall compliance with applicable 787 main and APU lithium-ion battery safety requirements was shown through formal analyses and tests. In addition to the Boeing analysis and tests noted previously, analyses and tests were performed by Thales and GS Yuasa, which were reviewed by Boeing project engineers, Boeing safety reliability and maintainability engineers, and Boeing authorized representatives. Formal analyses included a battery functional hazard assessment, fault tree analysis, and failure mode and effects analysis as well as a battery and battery charger system safety assessment. Battery testing consisted of full-performance, environmental qualification, and destructive tests. The destructive tests included external short circuit (low and moderate impedance shorts at battery terminals), overcharge (charge battery at 36 volts for 25 hours), high-temperature storage (185° F for 18 hours), and overdischarge (discharge battery to zero volts) tests. Boeing indicated that the tests found no evidence of cell-to-cell propagation failure or fire.

Boeing's safety assessment report noted that endurance testing, during which the battery is cycled and exposed to various operating temperatures over time, was also performed.⁴⁹ At the conclusion of its testing and safety assessment process, Boeing prepared documented compliance data supporting each of the nine special conditions in FAA document 25-359-SC.

1.8 Federal Aviation Administration Actions After Battery Incidents

On January 11, 2013, the FAA announced that it would be undertaking a comprehensive review of the 787's critical systems⁵⁰ and the possibility of further action pending new data and information. The FAA stated that, in addition to a review of the 787's design, manufacture, and assembly, the agency would validate that the 787 battery

⁴⁹ Endurance testing was not a certification requirement but was performed at Boeing's option.

⁵⁰ The FAA stated that this comprehensive review would "put an emphasis on the electrical system in the airplane. This includes components such as batteries and power distribution panels." The FAA further stated that the review would also "look at how the electrical and mechanical systems of the airplane interact with one another."

and the battery system were in compliance with the special conditions that were part of the 787's certification (as discussed in section 1.7.1 and the appendix).

On January 16, 2013, the FAA issued emergency Airworthiness Directive (AD) 2013-02-51 to address a potential battery fire risk in the 787.⁵¹ The emergency AD “was prompted by recent incidents involving lithium ion battery failures that resulted in release of flammable electrolytes, heat damage, and smoke on two Model 787-8 airplanes.” The emergency AD indicated that these conditions “could result in damage to critical systems and structures, and the potential for fire in the electrical compartment.” The emergency AD instructed owners and operators of Boeing 787-8 airplanes “before further flight, “modify the battery system, or take other actions, in accordance with a method approved by the Manager, Seattle Aircraft Certification Office.”⁵² On February 22, 2013, the FAA issued AD 2013-02-51, which stated that emergency AD 2013-02-51 had previously been sent to all known US owners and operators of 787-8 airplanes but that “this AD is effective [today] to all persons except those persons to whom it was made immediately effective by Emergency AD 2013-02-51.”

1.9 Additional Information

To understand the potential impact of smoke generation resulting from a battery failure in the cabin and cockpit environment, the NTSB documented the environmental control system on the incident airplane. This system provides pressurized and heated or cooled air to the 787 passenger cabin and E/E bays and enables smoke removal.

The aft E/E bay contains two smoke detectors. When smoke is detected, the avionics cooling function is designed to exhaust smoke overboard through fans in the cooling ducts and changing supply valve positions (and the use of differential pressure if the airplane is in flight). During this incident, the supply valves (which are electrically driven) lost electrical power after the APU shut down because the APU was the only source of electrical power being used at the time. As a result, smoke generated by the APU battery could not be effectively redirected outside the cabin and aft E/E bay.

⁵¹ Earlier that day, JAL and All Nippon Airways had voluntarily decided to stop 787 operations as a result of the battery event in Takamatsu, Japan. On January 17, 2013, the Japan Civil Aviation Bureau issued a directive with the same content as FAA emergency AD 2013-02-51. Civil aviation authorities in other countries also required operators of 787 airplanes to temporarily cease operations.

⁵² One US operator had six 787s in service when the emergency AD was issued.

2. Ongoing and Planned Investigation Activities

As previously stated, the NTSB's investigation of the JAL 787 battery fire is continuing. Below are activities that are either currently underway or planned by each of the investigative groups. The scope of the testing and examinations may change as investigative data are collected.

Battery Group

- Document the internal components and windings of battery cells.
- Test exemplar battery and cells for potential high-resistance short circuits.
- Review Boeing/Thales/GS Yuasa battery abusive testing reports.
- Document the results of the CT scans of the individual cells from the main battery.
- Review the CT scans of the Hall effect current sensor from the APU battery and document the results.
- Conduct CT scanning on individual cells of an exemplar battery and document the results.

Airworthiness Group

- Document certification background of battery and BCU.
- Examine charge rates and conditions for the battery and BCU as a subsystem.
- Examine battery ratings and the relationship between battery degradation and certification standards.
- Review existing ground and flight test data on bus loading and system response during transient conditions.
- Further examine the BMU and BCU.

Manufacturing Data Group

- Review documentation related to the design, engineering, and production of the battery system, with particular attention to the coordination of responsibility and authority of the contractors and subcontractors and the communication of design and engineering requirements.
- Develop a manufacturing process flow from data requested from Boeing, Thales, GS Yuasa, and KAI.
- Review findings from audits conducted by Boeing and the FAA.
- Review documentation from and conduct interviews at Thales, KAI, and GS Yuasa.

System Safety and Certification Group

- Examine the safety assessment process used to evaluate the lithium-ion battery design, including the underlying assumptions, tests, and data that support conclusions used in the analysis.
- Review the testing and analysis done by Boeing, Thales, and GS Yuasa to characterize the cell and battery failure conditions.
- Document and examine the flow-down of design and manufacturing requirements that have an impact on the failure modes of interest within the battery and cells.
- Research and document the evolution of safety analysis standards as they relate to evaluating and mitigating safety risks for lithium-ion battery cells and battery packs.
- Review and document the certification process steps taken to evaluate the battery design against the FAA's special conditions and examine the roles and responsibilities of the FAA, Boeing, Thales, and GS Yuasa in that process.

Environmental Issue Area

- Document and evaluate the toxicity of combustion byproducts that accompany lithium-ion battery fires.

- Document 787 lower lobe ventilation system strategies for clearing combustion byproducts resulting from lithium-ion battery fires to evaluate the effectiveness of mitigation strategies used to address occupant protection certification requirements.

Flight Data Recorder Group

- Document relevant data from the incident airplane's previous flights. (The FDR contained about 58 hours of data. The incident flight, which was the last recording on the forward and aft EAFRs, comprised 13 hours of data.)
- Document the true source and data path of main and APU battery parameters, including possible sources of repeated values and filtering.
- Document the true source and data path of relevant EICAS message discretes, including the triggers for each message.
- Investigate the dynamic accuracy of the FDR.
- Document FDR recording start and stop logic.

Appendix—Boeing 787 Type Certification Special Conditions 25-359-SC

The FAA issued the following nine special conditions, in place of the electrical equipment and installation requirements of 14 CFR 25.1353(c)(1) through (c)(4), for the design and installation of lithium-ion batteries as part of the type certification basis for the Boeing 787-8:

(1) Safe cell temperatures and pressures must be maintained during any foreseeable charging or discharging condition and during any failure of the charging or battery monitoring system not shown to be extremely remote. The lithium ion battery installation must preclude explosion in the event of those failures.

(2) Design of the lithium-ion batteries must preclude the occurrence of self-sustaining, uncontrolled increases in temperature or pressure.

(3) No explosive or toxic gases emitted by any lithium-ion battery in normal operation, or as the result of any failure of the battery charging system, monitoring system, or battery installation not shown to be extremely remote, may accumulate in hazardous quantities within the airplane.

(4) Installations of lithium-ion batteries must meet the requirements of 14 CFR 25.863(a) through (d).

(5) No corrosive fluids or gases that may escape from any lithium-ion battery may damage surrounding structure or any adjacent systems, equipment, or electrical wiring of the airplane in such a way as to cause a major or more severe failure condition, in accordance with 14 CFR 25.1309(b) and applicable regulatory guidance.

(6) Each lithium-ion battery installation must have provisions to prevent any hazardous effect on structure or essential systems caused by the maximum amount of heat the battery can generate during a short circuit of the battery or of its individual cells.

(7) Lithium-ion battery installations must have a system to control the charging rate of the battery automatically, so as to prevent battery overheating or overcharging, and,

(i) A battery temperature sensing and over-temperature warning system with a means for automatically disconnecting the battery from its charging source in the event of an over-temperature condition, or,

(ii) A battery failure sensing and warning system with a means for automatically disconnecting the battery from its charging source in the event of battery failure.

(8) Any lithium-ion battery installation whose function is required for safe operation of the airplane must incorporate a monitoring and warning feature that will provide an indication to the appropriate flight crewmembers whenever the state-of-charge of the batteries has fallen below levels considered acceptable for dispatch of the airplane.

(9) The Instructions for Continued Airworthiness required by 14 CFR 25.1529 must contain maintenance requirements for measurements of battery capacity at appropriate intervals to ensure that batteries whose function is required for safe operation of the airplane will perform their intended function as long as the battery is installed in the airplane. The Instructions for Continued Airworthiness must also contain procedures for the maintenance of lithium-ion batteries in spares storage to prevent the replacement of batteries whose function is required for safe operation of the airplane with batteries that have experienced degraded charge retention ability or other damage due to prolonged storage at a low state of charge.

The FAA noted that these special conditions were “not intended to replace 14 CFR 25.1353(c) in the certification basis of the Boeing 787-8 airplane” and that the special conditions applied “only to lithium-ion batteries and their installations.” The FAA also noted that the requirements of 14 CFR 25.1353(c) remained in effect “for batteries and battery installations of the Boeing 787-8 airplane that do not use lithium-ion batteries.”