



The Development and Testing of a Full-Scale Piloted Ornithopter

J.D. DeLaurier *

ABSTRACT

This article summarizes the design, construction, and testing of a full-scale piloted ornithopter. The project was based on the earlier development of a successful loft-span remotely-piloted proof-of-concept model, which provided the key analytical tools for assessing the feasibility of the full-scale aircraft. Also, many of the structural-design and construction methods were scaled from the model. However, there were several new development issues for the full-scale ornithopter, such as cockpit layout, pilot safety, and undercarriage design. Fully-instrumented taxi trials have been conducted in 1996, 1997, and 1998, which alternated with detailed design changes and strengthening. The most recent tests have brought this aircraft to the verge of full flight, resulting in controlled hops from which in-flight load data have been obtained.

RÉSUMÉ

Cet article la conception, la construction et le test d'un ornithoptère piloté grandeur nature. Le projet a été basé sur le développement au préalable d'un modèle de démonstration télépiloté réussi, ayant une portée de 10pi, qui a fourni les outils analytiques principaux pour évaluer la praticabilité de l'avion complet. Beaucoup de la conception structurale et des méthodes de construction ont été déterminées à partir du modèle. Cependant, il y eut plusieurs nouvelles questions de développement pour la mise au point finale de l'ornithoptère, tel que la disposition d'habitacle, la sûreté du pilote et la conception de train d'atterrissage. Des épreuves de roulement avec pleine instrumentation furent conduites en 1996, 1997 et 1998, qui alternaient entre les changements détaillés de conception et le renforcement. Les essais les plus récents ont placé cet avion au seuil de plein vol, ayant pour résultat des sauts dirigés, duquel des données de chargement en vol ont été obtenues.

INTRODUCTION

The purpose of this project has been to develop a human-piloted engine-powered ornithopter (flapping-wing aircraft). This objective is the culmination of two decades of research, which resulted in the successful flights of a scaled proof-of-concept model in 1991 (Figure 1). In the course of this, analytical methods and wing construction techniques were developed which are described in References 1 through 4. These provided the methodologies and information for the feasibility study and initial design of the full-sized ornithopter. This technological basis was subsequently supplemented by additional research specifically directed to the full-scale design, including: a non-linear flight-dynamic model (including wing flapping) for assessing stability and control (Rashid⁵), a non-linear take-off simulation model which accounts for flight and ground-contact dynamics (Machacek⁶), a wing design study for the full-sized aircraft which includes accurate estimates of aerodynamic, elastic, and inertial characteristics (Fowler⁷), test models of candidate composite spar designs for measuring elastic characteristics, fatigue characteristics, and maximum strength (Mehler⁸), and a detailed design study of drive-reduction systems for efficiently transmitting the engine power to the flapping wings (Tzembelicos⁹).

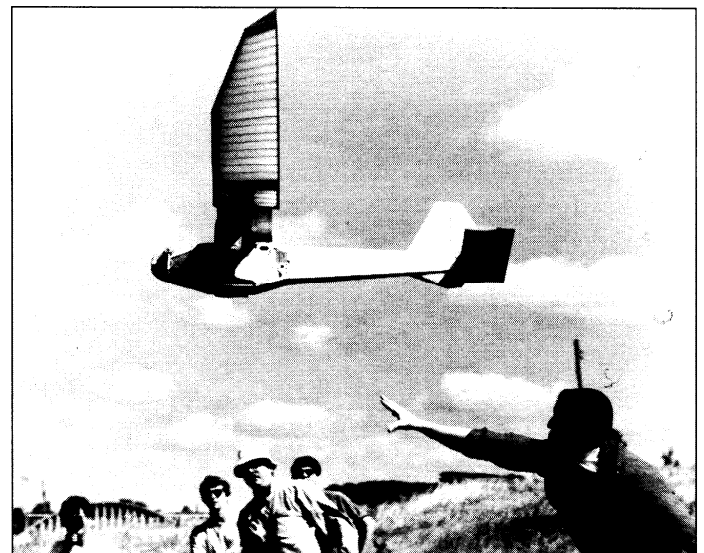

Figure 1.
Proof-of-concept model ornithopter being launched.

*University of Toronto Institute for Aerospace Studies

A certain amount of this work was complementary, in that the spar-sample measurements provided information for the wing-design study. Also, several of the above researchers



cooperated in obtaining wind-tunnel measurements of scaled components. This was part of a team effort that came together for the design and construction of the full-sized ornithopter, as described in this article.

DESCRIPTION OF THE AIRCRAFT

A general arrangement drawing of the ornithopter is shown in **Figure 2** and photographs of the uncovered and covered craft are shown in **Figures 3** and **4**. The design process began with the goal of building a single-seater aircraft powered by a 24-hp König engine, popularly used for ultralight aircraft. It was felt that by choosing such an engine an “ultralight philosophy” would prevail, resulting in an aircraft of sufficient simplicity and compactness to be achievable with a small team and a limited budget. At the same time, it was desired that the structure should meet Chapter 549 load criteria which requires the ability to experience 3.8 g before failure occurs. The consideration was that if the ornithopter had commercialization potential, it should have the operational robustness of a general-aviation airplane. As will be described, these goals were successfully achieved with an aircraft that is approximately four times bigger (in linear dimension) and 76 times heavier than the proof-of-concept model. In particular, its overall as-built characteristics are:

Span = 41.2 ft
 Fuselage Length = 24.5 ft
 Maximum Gross Weight = 7 10 lbs
 Engine = König SC-430 (24 hp, 3-cylinder radial, 2-cycle)
 Transmission = 3-stage chain & sprocket, 60 to 1 reduction
 Max Wing Loading = 4.81
 Max Power Loading = 0.163 hp/ft²
 Estimated Conditions for Level Cruising Flight = 5 1 mph at a flapping freq. of 1.05 Hz.

Further details about the aircraft are given in the following sections.

Wing Design and Construction

The wing consists of three hinged panels supported by centre pylons and outboard vertical links. The centre panel is driven in sinusoidal up-and-down motion that, in turn, drives the outer panels in flapping (as shown in **Figure 2**). The three-panel feature is patented because it has the merit of reducing the unbalanced oscillatory force applied to the fuselage (important for a piloted ornithopter). Also, three-panel flapping evens out the instantaneous power required throughout the flapping cycle (important for engine sizing). The centre panel has a constant chord and the outer panels are double tapered, which is aerodynamically efficient as well as providing a better balance through the spanwise area

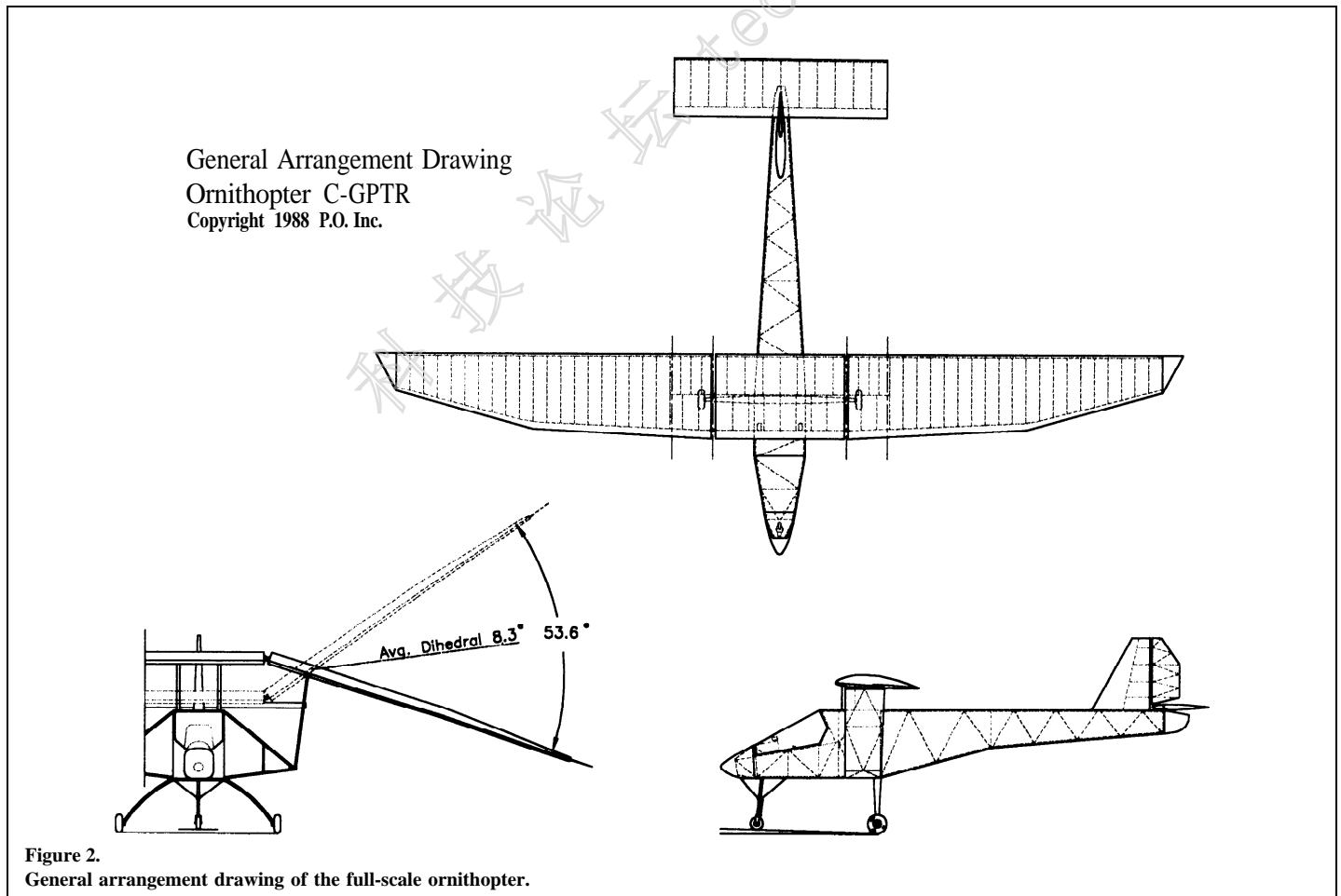

Figure 2. General arrangement drawing of the full-scale ornithopter.

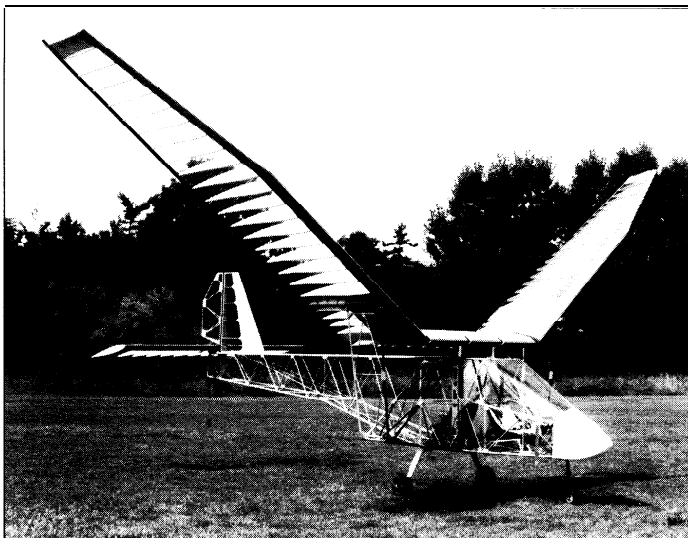

Figure 3.
Full-scale ornithopter before covering.

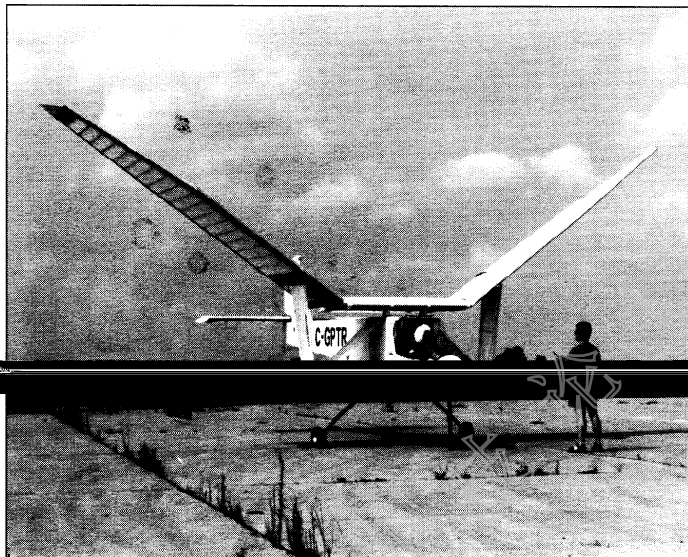

Figure 4.
Completed full-scale ornithopter, 1997.

distribution, in the manner described above. Also, the taper gives additional structural depth and strength to those inner portions of the spar that are most highly loaded. An 11 ft-span model of such a wing was built in 1992, and this was tested in the NRC 9-m wind tunnel in 1994 and 1995 as described in Reference 6. The full-sized wing scales nearly identically to this 1992 wing, including the upstroke and downstroke flapping geometry.

The full-scale wing incorporates the S 1020 airfoil designed by Michael Selig, of the University of Illinois, for ornithopter application (Reference 3). The inner portion of the wing uses this airfoil, and the outer tapered portion linearly transforms this to a Selig and Donovan SD8020 symmetrical section at the tip. Further, the requirement for torsional compliance of the wing was achieved with the patented “shearflex” feature (References 2 and 4) in which the trailing edge is “split” in order to allow a wing with a thick double-surface airfoil to structurally act as if it

were composed of two compliant single-surface wings. Such features allow the design of a flapping wing with high propulsive efficiency, as described in Reference 4.

The analytical foundation for this work is a program called “FullWing” (Reference 4), with which one may predict the performance of a flapping wing. An experimental study of spar characteristics for a full-sized wing was initiated by Suppanz¹⁰ which provided inputs for the application of FullWing to the feasibility study of a full-scale ornithopter. The results were of sufficient promise that this work was carried on by Fowler⁷, resulting in the design shown in Figure 2. As before, this involved a combination of analysis and experiment, with several spar samples being constructed and tested. It was important to demonstrate that the desired elastic characteristics could be obtained with a spar that was sufficiently light and strong. Therefore, besides measuring stiffness in bending and twisting, the spar samples were also loaded to failure.

The spar construction is shown in Figure 5, consisting of a “wet lay-up” of Kevlar cloth and epoxy over a leading-edge shaped structural-foam core backed with a carbon-fibre reinforced shear web. The ribs are cut from 1/2-inch wide sheets of structural foam and capped with basswood strips. These are glued to the shear web; and the trailing edges are unidirectional carbon-fibre strips. The finished wing, before covering, is shown in Figure 6.

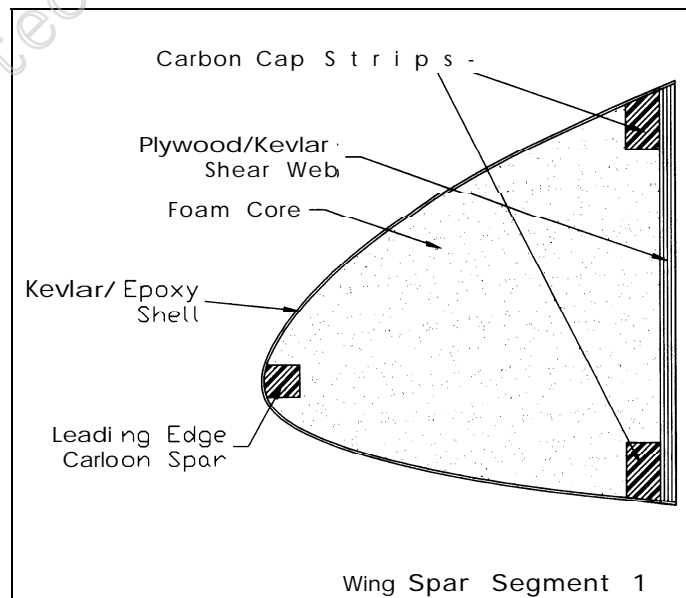

Figure 5.
Cross-sectional construction of the wing spar.

The covering material is a lightweight polyester fabric applied with an adhesive and coated with a clear synthetic varnish used for finish and shrinking. It was required to reinforce the attachment of the fabric to the tops of those ribs that do not slide under the fabric (a sheafflexing action requires that, for every rib, one edge be fixed to the fabric while the other edge is free to slide, lubricated with paraffin wax). Normally, stitching is used; however, the foam and capstrip design did not allow

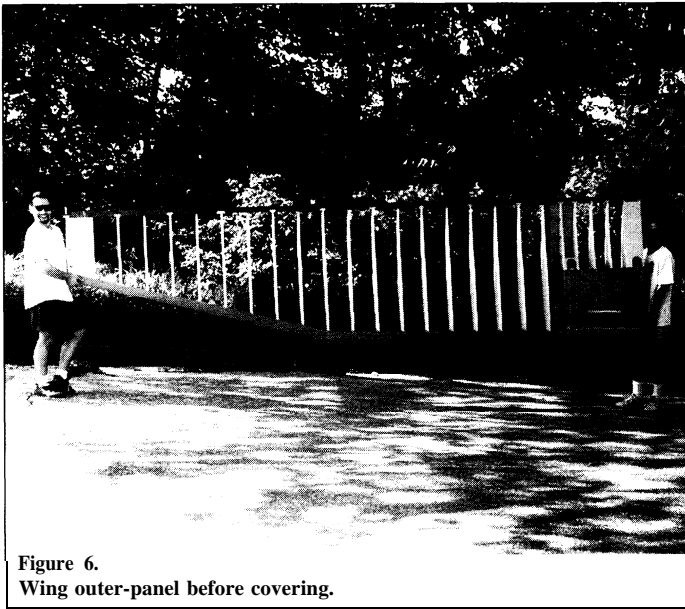

Figure 6.
Wing outer-panel before covering.

this to be done without weakening its structure. Therefore, the fabric was secured with small screws inserted into epoxy-filled holes drilled into the basswood capstrips.

Finally, aluminum clips are used to hold the two trailing-edge strips in light contact with each other. These are spaced along the trailing edge at every rib location. In order to accommodate the shearflexing action, the clips were glued to either the upper or lower trailing-edge strip (on the side where the strip was attached to the rib). The free-sliding inner surface of the clip was carefully smoothed and rubbed with wax.

Empennage Design and Construction

The size and location of the tail surfaces were scaled from that for the proof-of-concept model. This aircraft had flown in a stable and controllable fashion; and it was decided that a direct proportioning was a sensible approach for the baseline full-sized design. Later, the full flight-dynamic analysis described in Reference 5 predicted that the initial sizing would give very acceptable behaviour, and the empennage was built to these proportions.

The horizontal tail is an all-moving stabilator, pivoted slightly ahead of the 1/4-chord pressure centre location in order to minimize aerodynamic back-driving moments through the control system. Its mass centre is somewhat aft of this pivot, but close enough to reduce inertial-reaction back-driving moments to manageable levels. If needed, balancing with counterweights is a readily accessible option.

The construction of the stabilator is a variation of that for the wing, consisting of a Kevlar/carbon/foam leading-edge spar, foam and basswood ribs, and a carbon fibre trailing edge. The difference is that because torsional compliance is not desired, the Kevlar cloth lay-up on the spar is oriented to resist twisting. Also, the trailing-edge strips were joined (no shearflexing action). Therefore, when the fabric was applied, it was possible to stitch it on the ribs in the traditional fashion, looping it the full depth of the rib.

Back driving is not an issue for the vertical tail. That, plus the difficulty of designing an all-moving surface pivoted at one end (compared with that for the centre-span pivoted stabilator), compelled the use of a fixed fin with a hinged control surface (rudder). The calculated loading allowed traditional wooden construction.

Fuselage Design and Construction

The overall dimensions of the fuselage were dictated by the placement of the empennage relative to the wing, the location of a comfortable pilot enclosure (cockpit) forward of the wing, and the incorporation of an engine/drive-module unit beneath the wing. Furthermore, the fuselage had to have geometry that was logical for the attachment of the outrigger struts (Figure 2) and undercarriage. Therefore, the central element was compelled to be a parallel-sided prismatic shape. This unit, named the "thorax", would include the engine/drive module and provide hard-points for the strut and main undercarriage attachment.

The required cross-section for the thorax gave more than sufficient cockpit cross-sectional area for the pilot. Therefore, what remained was to shape an enclosure that provided sufficient pilot leg room as well as structural accommodation for a forward undercarriage element (nose gear). Also, it was desired to incorporate a windscreen (canopy) shape consisting of a simple transverse curve. A wind-tunnel study was performed which showed that if the fore-and-aft slope of the canopy is blended to the rest of the cockpit and the following thorax (as shown in Figure 2), the fore-body drag is very acceptably low.

The aft fuselage could have been a straight-tapered shape aft from the thorax, but this would have resulted in an overly large cross-section (from structural considerations) and excessive skin-friction drag. Therefore, it was decided to use the cranked-fuselage feature from the model. A wind-tunnel study of the complete fuselage (Duffin), including thorax and cockpit, showed attached flow and acceptable drag values over a reasonable angle-of-attack range.

The fuselage is a fabric-covered space-frame structure. The loads taken up by the frame elements, in reaction to the in-flight applied external loads from the wing, empennage, struts, undercarriage, etc., were calculated from finite-element programs. This allowed the sizing and material selection for the metal tubing from which the fuselage was constructed. In particular, the thorax was built from welded steel tubes with welded lugs to provide hard-points for the engine/drive-module support and outrigger strut attachments; and the aft fuselage and cockpit were built from riveted and gusseted aluminum tubes. This is a traditional type of aircraft construction which was particularly appropriate in this case because of the large required cross-sectional areas, the ease and economy of fabrication, and the ease of access and modification (if required).

Outrigger Struts and Vertical Links

A two-dimensional space-frame structure from metal tubing offered a simple and lightweight solution for the outrigger and vertical-link structures. As with the fuselage, a finite-element program was applied to facilitate the size and material selection.



This resulted in a mixture of steel tubing with welded gussets in the heavily loaded leading-edge, and aluminum tubing with riveted gussets in the more lightly loaded aft portion. Also, pin connections were used except for the junction where the outrigger struts join together.

Streamlining was provided with elliptical leading-edge fairings and sharp trailing-edge fairings attached to the fabric-covered structure. Also, the gusseted junctions where the outrigger struts join together, as well as the junctions where the vertical intermediate tubes join the upper and lower outrigger struts, were streamlined with shaped and painted structural foam pieces attached with quick-setting epoxy. As for the junctions between the outrigger struts and the fuselage, it had originally been assumed that this would be a source of considerable interference drag. However, wind-tunnel tests on the fuselage model showed that the drag difference between faired and unfaired junctions was surprisingly small. Therefore, these were left unfaired.

Undercarriage

It was anticipated that ground take-off for an ornithopter would require careful study. Therefore, a time-marching, non-linear, longitudinal (no lateral motion) analysis was developed by Machacek⁶, with which he studied candidate take-off scenarios and how they would be affected by various control strategies and undercarriage characteristics. The analysis showed that it was important to keep a nose-down attitude throughout the ground acceleration. Only when flight speed is attained should the nose be lifted for take-off. Otherwise, considerable bouncing is caused by the oscillatory lift force when the aircraft becomes light on its wheels.

It was decided to install a traditional tricycle undercarriage arrangement. The original sizing and positioning were based on those accepted for fixed-wing general-aviation airplanes. The main gear was a carbon fibre/epoxy cantilever unit supporting wide-track "balloon" tires. Therefore, a combination of the elastic cantilever-beam properties and the elastomeric characteristics of the tires gave the springiness and damping. Further, for the 1996 taxi trials, drum-brake units were attached to both wheels of the main gear, mechanically and differentially actuated by foot pedals in the cockpit.

A straight strut composed of telescoping tubing with an internal spring supports the nose gear. This was originally steered by side-to-side motion of the control stick, which also provided coupled motion to the rudder.

Engine/Drive-Module Unit

As mentioned before, the ornithopter is powered with a König 3-cylinder, 2-cycle, radial engine that produces 24 hp at 4000 rpm. The drive-reduction unit, shown in **Figure 7**, was designed to efficiently transmit this power to the wings in order to flap at a maximum frequency of 1.2 Hz. Its drive ratio of 60 to 1 is achieved with a three-stage reduction using chains and sprockets, terminating in a Scotch-yoke mechanism to convert the rotary motion to oscillatory motion driving the vertical pylons upon which the centre panel is mounted (**Figure 2**).

Very early in the program, Tzembelicos⁷ made a comprehensive study of various candidate drive-reduction transmissions, such as gearboxes, belts, harmonic drives, and planetary systems. It was concluded that the chain and sprocket system offered the simplest and most efficient power-transmission capability for the lowest weight. In this, he worked closely with the author's research partner, Jeremy M. Harris, and the subsequent detailed design and fabrication was performed by Mr. Harris. This work, itself, would require a full report to adequately describe.

Originally, the way in which the drive-reduction module was coupled to the engine (the zero stage) was through a simple belt and pulley arrangement, which provided an additional 1.6 to 1 drive reduction. The reasoning behind this was the desire to have a means for de-clutching the engine from the module in case this was required for flight safety during an engine-out situation. Therefore, the belt was held under tension by a spring-restrained idler pulley, which could be de-clutched by the pilot with a cable and lever mechanism. However, the 1996 taxi trials compelled a design change to a non-clutched chain-and-sprocket arrangement, as described further in the article.

Also mounted on the engine shaft is a flywheel/fan unit. Because of the variable back-loads due to the flapping, the engine requires a flywheel to provide continuous, even, running. At the same time, the internal location means that the engine needs a fan for forced cooling. Both functions were provided by a design with an annular flywheel supported by spokes shaped as fan blades.

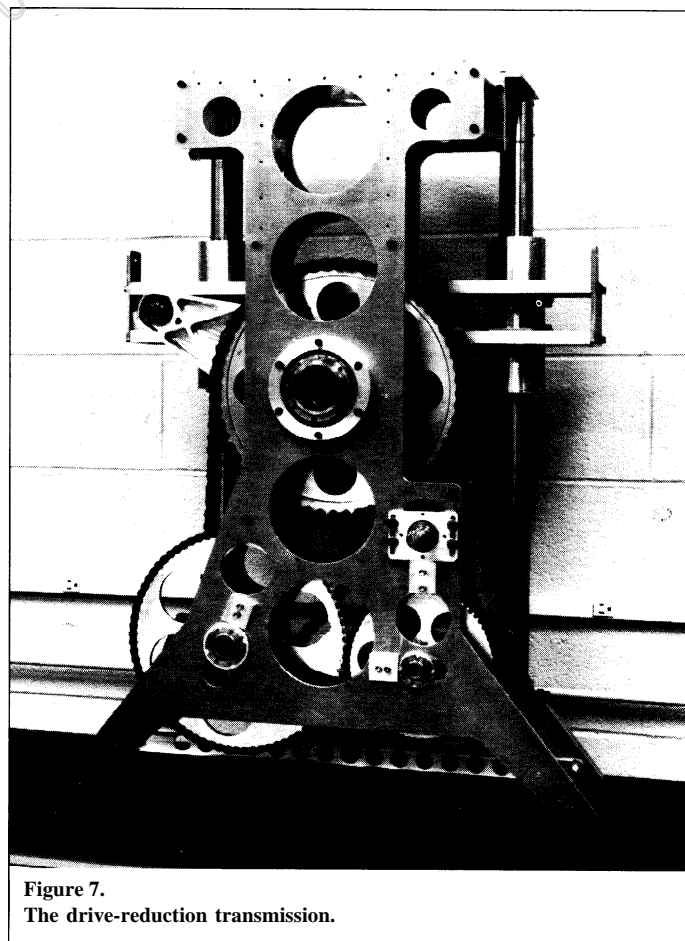

Figure 7.
The drive-reduction transmission.



Control System

The ornithopter has no direct roll control because there is no obvious way to install ailerons (or some equivalent aerodynamic surface) to the shearflexing wings. Therefore, turning capability is provided by yaw-roll coupling, where yawing produced by rudder deflection acts in concert with the dihedral angle of the wing to roll the aircraft. That is, the yawed windward wing sees an incremental increase in angle of attack and the leeward wing sees an equal decrease. This produces a rolling moment that banks the aircraft into the direction of the rudder deflection, thus laterally tilting the lift vector and pulling the aircraft into a turn.

As seen in **Figure 2**, the wing has an average positive dihedral angle because its maximum upstroke angle is larger than its downstroke angle. In fact, this effective dihedral is more than the arithmetic mean if one does a time averaging of the dihedral angles through the flapping cycle. From the excellent turning performance of the proof-of-concept model, it was clear that yaw-roll coupling works well as a means for directional control.

Traditionally, foot pedals (or a foot bar) are used for actuating the rudder and lateral motion of the control stick actuates the ailerons. In this case, the rudder is actuated by side-to-side motion of the control stick. As mentioned previously, foot pedals were originally used to engage the brakes on the main undercarriage. This was modified in 1997, by the pilot's request, to a foot bar for steering the nose wheel (decoupled from the control stick) with heel pedals attached for the brakes. Fore-and-aft motion of the control stick actuates the stabilator. Because the stabilator is pivoted near its aerodynamic centre (identical, in this case, with its pressure centre) an artificial centering force is provided to the pilot by attaching strong fore-and-aft tension springs to the lower part of the stick.

As much as possible, a traditional cockpit arrangement was sought. For example, the engine is controlled with a throttle quadrant mounted on the left-hand side of the cockpit. Also, the instrument suite is very similar to that typically found in a small general-aviation airplane (altimeter, airspeed, engine rpm, head temperature, etc.). The one important additional instrument is the large LED display of the flapping frequency.

Safety Features

Because this is a unique experimental aircraft, the pilot's safety is a prime consideration. In addition to Transport Canada requirements, such as a standards-compliant restraint system and small fire extinguisher, additional features include cushioning of the seat with special energy-absorbing foam and a ballistic-parachute system. This is installed so that if the aircraft experiences in-flight structural failure, a parachute attached to the fuselage may be quickly deployed by a small solid-fuel rocket activated by pulling a handle in the cockpit. This system, which has been very successful for ultralight and small general-aviation aircraft, would lower the whole aircraft plus pilot.

Also, as mentioned before, it was attempted to design the ornithopter to FAR 23 criteria, which requires structural ability to experience 3.8-g before failure occurs. The application of

these criteria to the more traditional components was very straightforward. However, it was found that the 3.8-g loading case applied to the shearflex wing produces lower bending moments than for a rigid wing. This is because the torsional compliance unloads the outer portions, biasing the loading towards the centre portion of the wing.

1996 TESTS

Although the ultimate goal is to achieve flight, there were several important ground-based tests leading up to this. In all cases these were documented with video cameras, sometimes with the high-speed shutter feature engaged in order to assess the dynamic behaviour of the wing. Also, the wing spars were instrumented with strain gauges. The signals from these were collected with a data-acquisition system, and then stored and processed with a laptop computer. The results, through calibration constants, gave time histories of the torsion and bending moments on the wing spars.

Static Tests

The first set of tests, in 1996, involved the ornithopter flapping under restrained conditions in a large covered structure (the "ACV Dome") at the University of Toronto Institute for Aerospace Studies (UTIAS). There were several purposes for this, the first of which was to learn if the engine/drive-module unit was capable of flapping the wings to the maximum frequency of 1.2 Hz. The design calculations were confirmed in that this was readily achieved. Except for tightening the clutch spring and some screws, the engine/drive-module unit performed up to expectations.

At the same time, the average static-thrust values were measured with a spring scale. This is important for initiating ground roll. At frequencies below 0.7 Hz the value was very low. However, as the flapping frequency exceeded 1.1 Hz, the average thrust achieved was approximately 30 lbs. It is understood that, for the engine power used, a well-matched propeller could produce a larger value. Lower static thrust seems to be characteristic of shearflex wings which are optimized for cruising flight. However, it was postulated that if the ornithopter can reach some significant speed during the ground run, the leading-edge suction effect, as described in Ref. 1, would begin to provide the additional thrust required to achieve take-off speed. The static-thrust values promised that the aircraft would at least initially accelerate.

The flapping behaviour of the wing was recorded and studied. This included videography of the dynamic twisting and close-in recording of the sheafflexing action. Initially, the dynamic behaviour was worrisome in that the phase angle between flapping and twisting was not close to the design value of -90 degrees. From the FullWing computer program (Reference 4), a flapping wing performs best if the phase angle is near -90 degrees. That is, the pitch angle is at its maximum leading-edge down value at mid-downstroke, and maximum leading-edge up value at mid-upstroke. It was then realized that the veracity of FullWing is restrained to flight speeds near cruising, where the flow over the wing is mainly attached throughout the flapping cycle. It



offers little guidance for static-wing performance when the flow is mainly separated. A static-flapping sequence recorded in 1991 for the proof-of-concept ornithopter model was studied and it showed wing behaviour much like that for the full-sized aircraft. It was clear that such phasing is characteristic for these wings in static-flapping conditions. This may also serve to explain why the static thrust is relatively low. Since static thrust comes mainly from the forward tilt of the normal-force vector, -90 degree phasing would have given larger values (maximum normal force at maximum tilt). At full flight speeds, where the assumptions of FullWing apply, the phasing should become nearly -90 degrees. This behaviour was, in fact, observed from the flight videos of the proof-of-concept model.

The methodologies for acquiring bending and twisting-moment data are discussed, in detail, in Reference 8; and an example plot (from a 1997 test) is shown in **Figure 8**. The acquisition of this data was important for every test throughout the program, both static and taxiing. The reduction of the most recent readings is now the subject of a forthcoming M.A.Sc. thesis, from which it will be possible to compare the experimental loads with those predicted from analysis.

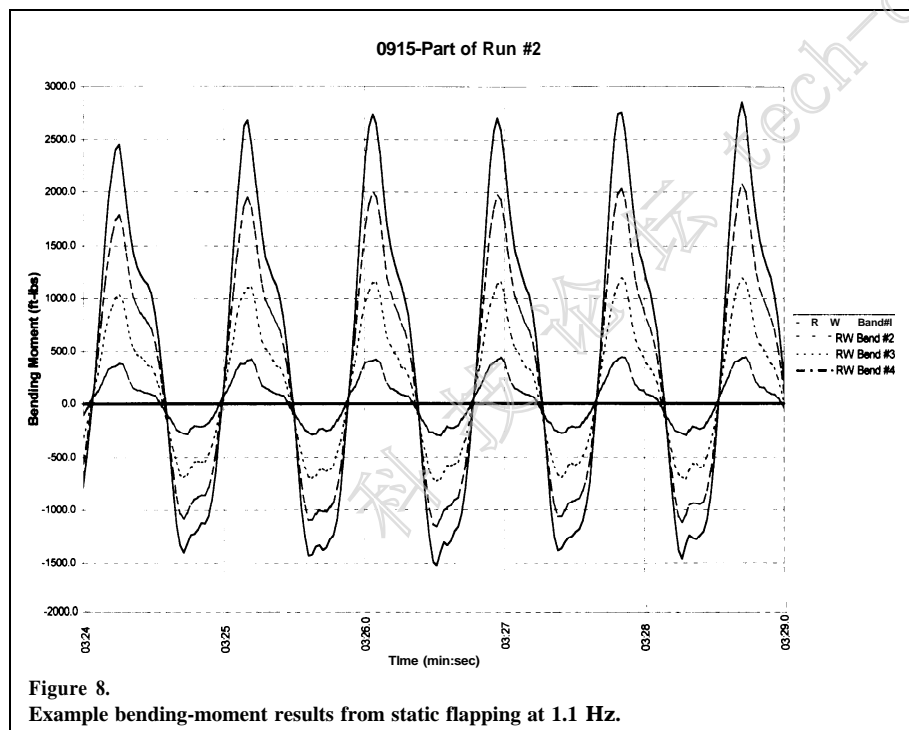

Figure 8.
Example bending-moment results from static flapping at 1.1 Hz.

The static-flapping tests also gave an opportunity for the pilot, Patricia Jones-Bowman, to become acquainted with the cockpit environment, such as throttle sensitivity and shaking due to flapping. Calculations show that, in full flight, the pilot will experience oscillatory accelerations of plus-or-minus 0.5 g at 1.05 Hz. When the pilot was exposed to this in the UTIAS motion-based simulator she readily concluded that such oscillation would not impair her ability to safely control the aircraft. Ground-interaction dynamics, however, can only be experienced by taxi runs.

Taxi Testing

When the static-flapping tests were satisfactorily completed, the ornithopter was transported on 2 October 1996 to the airfield at de Havilland Aircraft (Downsview, Ontario) for ground-run (taxi) tests. The Canada Lands Corporation made a large adjacent hanger space, formerly belonging to the Canadian Armed Forces, available. The ornithopter was assembled and the initial experiments were performed in the hangar. First of all, the rolling friction on a level concrete surface was obtained by pulling the aircraft, from underneath the nose, with a spring scale. With the tires inflated to the recommended maximum 70 psi, the measured rolling friction was 10 lbs.

On 3 October, the aircraft was rapidly pushed around inside the hangar with the pilot in the cockpit in order to give some initial familiarity with ground handling and braking. That afternoon, the ornithopter taxied on its own for the first time. This was done in the hangar, which was very large and empty. As expected from the static-thrust data, the aircraft did not start moving until the flapping frequency was about 0.7 Hz. At this point the ornithopter was able to accelerate to a rapid walking pace. The pilot noted that the nose-wheel steering was overly sensitive, and adjusting the linkage reduced this. The next taxi test was done outdoors during the late morning of 4 October, on the de Havilland runway. Again, the intention was to taxi at a relatively slow speed so as to build up pilot familiarity and sort out any ground-handling problems in a measured fashion. In this case, with the wings flapping at approximately 0.8 Hz, the aircraft achieved a speed that required the ground crew to run in order to keep up. This was encouraging performance; however, the wind was quartering at about 8 mph, and it was observed that this cross-flow component was causing one of the wheels to lift on the main undercarriage. This was serious because the wing tips at maximum downstroke had a ground clearance of only about 1.5 ft. Any significant lateral tilting of the ornithopter during the take-off run would have caused wing-tip contact and damage. Because of this concern, and the increasing wind speed, further testing was halted.

The reason for the tilting problem was that the lateral spacing between the main wheels (track) was too narrow. Its proportions had been based on those generally acceptable for fixed-wing aircraft. This is clearly not sufficient for ornithopters because the large maximum dihedral angles during upstroke give considerable rolling moments in any kind of cross-wind. In retrospect, this behaviour is obvious and could have been analytically predicted. In any case, it was clear that further taxi testing required nearly dead-calm conditions.

The next tests took place during dawn of 6 October. The conditions were nearly calm, and giving the ground path a



small angle relative to the wide runway compensated for the small cross-flow component. After two preliminary slow runs, a faster test (at 22 mph) was performed. The pilot was able to readily accelerate to this speed, with the wings flapping at approximately 1.0 Hz. Soon thereafter, structural damage was observed near the right wing tip. The test was halted and the damage assessed. It was found that a 1/32-inch thick plywood sheet at the upper tip had torn loose from its attachment to the spar. Also seen were missing trailing-edge clips and broken ribs, to about 4 ft inboard from the wing tip.

The pilot stated that the ground-handling characteristics were at the limits of her ability to control the aircraft. She did not feel confident taxiing at faster speeds until the steering geometry was changed. This, plus the required wing repairs and strengthening, compelled the testing to cease and the ornithopter to be transported back to UTIAS. The onset of winter was a time to assess the lessons learned from the tests and to prepare for further trials in 1997. The most immediate action items concerned the wing, drive module, and undercarriage, as described below.

Wing Outer Panel Repair and Redesign

As seen in **Figure 6**, the structure of the wing outer panels is open between the ribs until the very last portion near the tip, which was covered (top and bottom) by 1/32" plywood full-chord sheets. These provided a spanwise-rigid surface upon which the tensioned fabric is anchored and also served the purpose of allowing the shearflexing action to carry through. That is, the trailing edges of the sheets are not constrained, relative to one another, in the spanwise direction.

Failure occurred when the upper sheet on the right wing tore loose from its attachment to the spar shear web. This may be what precipitated the subsequent wing damage. Therefore, a more robust redesign was called for. The sheets were removed and replaced with new 1/32-inch plywood sheets that were laminated, on both sides, with carbon-fibre cloth and epoxy. This considerable increase in stiffness and strength allowed their area to be reduced, thus recovering some of the weight increase caused by the lamination. Also, intermediate ribs were added under the sheets, providing additional support.

Finally, the tip rib was reinforced with 1/32-inch plywood laminated on either side of its foam core. This gave a stronger basis for supporting the triangular wing-tip component known as the "bat tip".

Drive-Train Redesign

Video of the 6 October taxi run (at 22 mph) showed that the duration of the downstroke was about twice that of the upstroke. Also, the wing twisting was jerky, with three distinct "jolts" during the downstroke. This observation was complemented by the strain-gauge readings, the graphs of which showed corresponding blips. From this evidence it was concluded that the "zero-stage" belt drive (the one between the engine and the drive module) was slipping, and it was decided to replace this with a chain and sprocket system (also with a 1.6 to 1 reduction). Recall that the V-belt drive was selected in order to provide a

means for de-clutching the engine from the drive module in case the engine cut out. In that instance, the wings could back-drive from the aerodynamic loads to a manageably stable positive dihedral angle. However, it was found that the wings could readily back-drive against the compression of the engine, with no de-clutching required. The only case where a clutch might be desirable is if the engine were to seize. However, this was discussed with the pilot who agreed that the positive chain drive offered more safety than a belt drive with uncertain grip.

Undercarriage Redesign

There were three aspects of the undercarriage that required attention. The first of these was the need to widen the cross track of the main gear to reduce lateral tipping from ground winds. The second was to increase ground clearance; and the third was to improve the nose-wheel steering.

An analysis confirmed the observation that the original undercarriage had too narrow a track for any reasonable resistance to crosswind tipping. It also showed that a wide track is particularly required by an ornithopter, with its exaggerated dihedral effect. Therefore a new main gear was designed which provides a 99" track instead of the original 61" track. At the same time, the aircraft was raised by 12" because, even when it was level, the tips came alarmingly close to the ground while flapping. At the same time, larger-diameter wheels were installed (13.5 inch diameter instead of the original 11.5 inch) incorporating hydraulically actuated disc brakes.

The nose gear had to be correspondingly lengthened, requiring bracing from external wire stays. Along with this change the steering arrangement was improved, as described earlier in the Control System section.

1997 TESTS

On 7 August 1997 the first taxi trial was conducted. The aircraft readily accelerated to 22 mph, which matched the best speed from the previous year. However, unlike 1996, the wings flapped smoothly and the pilot was satisfied with the handling and control. A subsequent taxi run achieved 32 mph. Again, this was very satisfactory. At this point the experiments ceased to allow for inspection of the aircraft and evaluation of the data. The external video cameras obtained an excellent record of the taxi runs, including the wing motions. It was clear that not only had the new zero-stage drive assembly eliminated the jerkiness from the 1996 tests, but also the phase angles between flapping and twisting were approaching the -90 degree behaviour predicted from the analysis.

Careful inspection of the airframe and drive-train showed no problems, so another taxi trial was scheduled for the following day. On this occasion the zero-stage chain slipped off its sprockets, bringing the test to a halt. The cause appeared to be excessive motion between the rigidly mounted drive module and the shock-supported engine. This was reduced by means of additional support between the two units (described in Reference 12) as well as increasing the chain tension.

The aircraft returned to the runway, on the morning of 25 August, with the improved zero-stage drive assembly.



However, as the flapping increased, the drive failed again. It was the same scenario as the failure on 8 August: the wings were flapping at 1.0 Hz and the aircraft was beginning its acceleration when the engine suddenly speeded up and the wings drooped down. At the same time, the chain dropped out of the fuselage and lay on the runway.

Again, relative motion between the drive module and engine appeared to be the problem. This was fixed by adjusting the shock-absorbing pads on the engine-mount assembly to reduce the motion and make it more symmetrical with respect to its nominal position. During subsequent run-ups the chain stayed on and performed properly. Therefore, it was decided that the aircraft was ready for more taxi trials. It should be noted, though, that this solution was not considered to be robust enough to chance a flight at altitude. A redesign is described later.

The next taxi runs were made on 1 September. The first run, in a light crosswind, was terminated at 26 mph because the windward wheel was seen to be lifting. Subsequent runs, on another branch of the runway, readily achieved 40 mph. However, the tests were terminated because the nose-wheel steering was behaving strangely. Inspection showed that the nose-gear strut had bent its support within the fuselage, and the guy lines were subsequently loose. Also, several of the support-plate rivets had worked loose or sheared. Therefore, the tests were ended until this problem could be assessed and repaired.

Upon viewing the video footage of the last taxi run, it was seen that the nose-gear assembly was seriously exercised. In fact, during the acceleration, the main-gear wheels were bouncing and lifting off the ground while the nose-gear was being driven down. Also, the nose-gear tire was being flattened to its rim (which was bent and deformed in places). Therefore, it was necessary to repair and strengthen the nose-gear support structure. Besides installing more robust components, the riveting incorporated a layer of 3M Scotch VHB industrial adhesive for additional reinforcement.

After some additional minor repairs, as well as increasing the nose-gear tire pressure, the aircraft returned to the runway on 15 Sept. The intention of these tests was to explore the effect of applying a certain amount of negative stabilator angle (trailing-edge up) so as to lighten the load on the nose wheel. On this occasion, the aircraft accelerated to a speed of approximately 40-mph and the applied stabilator caused a series of controlled bounces of increasing amplitude until the pilot throttled back. This was not sustained flight because the aircraft only rose during the downstroke of the wing and would touch down during the upstroke (**Figure 9**).

During the next run the pilot continued steering with the nose wheel after the bouncing began, and it was subjected to a side force that slackened one of its external wire stays. The run was ended and the aircraft was brought back to the hangar for inspection. At that time, no damage was found; and it was concluded that the side load simply caused a stretching of the stay. These were adjusted and tightened; but the wind had picked up and no further runs were attempted.

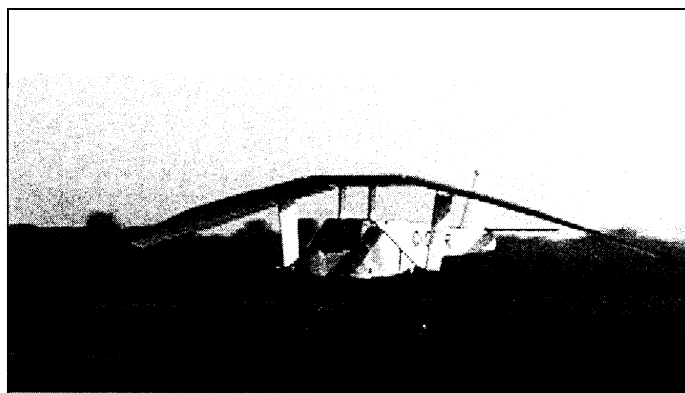

Figure 9.
15 September 1997 taxi trial.

The following day, 16 Sept., the team assembled early in the morning for further taxi tests. However, while rolling the aircraft to its starting position, ground crew members noticed flexibility in the thorax structure. Inspection revealed loose, sheared, or missing rivets in some of the junctions. It is likely that this over-stressing was caused by the bouncing impacts of the previous day.

A field repair was done alongside the runway. The remaining rivets were drilled out and replaced with stainless steel rivets. The aircraft was then positioned on the runway and the taxi run began. Soon after, a wing clip was seen to fall off and the run was called to a halt.

The aircraft was wheeled back to the hangar for inspection, and it was found that rivets in the upper thorax structure had again come loose. This had allowed lateral movement of the drive module to the extent that the foam leading-edge fairing on the right pylon was scraping against the thorax structure.

At this point, there was an almost simultaneous consensus that these taxi tests should not continue until the thorax structure was carefully inspected, analyzed, and reinforced. Also, the data should be reduced and studied to give information about the loads as well as insights on suitable takeoff strategies. Further, the whole issue of wing-clip attachment needed to be revisited, with appropriate laboratory tests. Therefore, the taxi trials were concluded for 1997 and the aircraft was brought back to UTIAS.

Evaluation and Repair of the Thorax and Outrigger Struts

Beginning in January 1998, the thorax and outrigger-strut structures were theoretically studied with a frame-analysis program (CADRE). Upon being subjected to the estimated bouncing loads, the analysis clearly predicted the areas of over-stressing that were actually observed. With this program as a guide, modifications to the structure were evaluated; it was found that a satisfactory repair could be obtained by replacing certain aluminum tubes with titanium or steel, and using stronger, CherryMax, rivets. These repairs were performed, along with straightening the lower, horizontal, steel thorax tubes (bent from the 1997 bounces). Where possible, riveted joints were reinforced with the 3M Scotch VHB adhesive.



Take-off Simulation

A new non-linear simulation of the takeoff and flight of the ornithopter was developed, based on software (Working Model) that gives solutions for complex dynamic systems "constructed" in a modular fashion. As with Machacek's simulation (Reference 6), this is constrained to longitudinal motions (no lateral dynamics), but allows ground-contact behaviour and control interactions. Important input parameters are the spring constant and damping of the main undercarriage. These were experimentally evaluated by mounting the main undercarriage on a special rig for drop testing. The motions were recorded with a video camera and digitized for a best fit to an analytical oscillation and damping model. It should be noted that because the main undercarriage spreads under load, the wheels were bounced on oiled plastic sheets so as to minimize side scrubbing and, thus, spurious damping (this is minimal when normally rolling and bouncing).

The simulation provided valuable guidance for takeoff strategies; but the most important result was the prediction that shortening the nose-gear would suppress bouncing. This is because the aircraft's pitch angle would be more nose-down, therefore reducing the mean-lift buildup as speed increased. This change was incorporated by means of a three-inch shortening of the nose-gear strut.

Engine Restraint

It was decided to deal with the chain-jumping problems of the zero-stage drive by proving a rigid restraint between the engine and the drive module. This was done with a steel-tube structure mounted between the engine's upper cylinder head (using the auxiliary cooling-head bolts) and the drive module's thick aluminum plate. A certain amount of shock absorption is provided with elastomer washers on those bolts attached to the drive module.

New Instrumentation

The simulation showed that it is important for the pilot to precisely know the stabilator angle at all times. Because the unsteady cockpit environment obscures this, a potentiometer was mounted on the control stick that, in turn, sends a signal to a vertical bank of light-emitting diodes (LEDs) mounted on the instrument panel. The number of lights and their colours give clear and immediate information about the stabilator's pitch angle with respect to the aircraft.

Another new instrument was a large, easily read flapping-frequency display. This had been sought after since the beginning of the program, but the various candidate designs had problems with interference, sensitivity, etc. However, these were finally overcome with a magnetically-actuated counter system to give a reliable and valuable instrument.

Other new instrumentation, for the on-board data-acquisition system, includes a three-axis accelerometer suite attached to the cockpit in the nose-gear location. However, it should be noted that these extra channels became available by virtue of the progressive deterioration and failure of certain wing-spar mounted strain gauges.

Wing-Clip Adhesion

The use of epoxy glue from the 3M Corporation (Scotch-Weld DP-420) finally solved the persistent problem with wing-clip adhesion. A systematic series of load and cycle tests were performed at UTIAS, and the epoxy product outperformed the cyanoacrylate glues by a large margin. Because of this result, all clips were removed, cleaned, and reglued. During the removal, the clips popped off alarmingly easy. However, when an epoxy-glued clip had to be removed and repositioned, this operation was reassuringly difficult.

1998 TESTS

Taxi trials began on 19 September. It was decided to constrain the flapping frequency to below 1 Hz and measure the corresponding speed. Five runs were performed, with the maximum flapping frequency of 0.88 Hz giving an equilibrium air speed of slightly over 25 mph. A new type of bouncing behaviour was observed. If, at the start of the run, the throttle was applied too rapidly, the nose-gear would experience considerable bouncing at the flapping frequency. A more gradual throttle application would suppress this, but it also resulted in a longer run to equilibrium speed. It was observed, though, that when the speed exceeded 15 mph, the bouncing greatly diminished.

Another 5 taxi runs were performed on 24 September, on which occasion a top speed of 42 mph was achieved with a 0.97 Hz flapping frequency. The stabilator-angle instrument was proving its worth in that a setting of zero degrees provided the smoothest runs. After the initial nose-gear bouncing, the aircraft would settle down to a "skimming" type of behaviour, with all wheels lightly and evenly bouncing in response to the flapping.

The taxi runs on 29 September evaluated two modifications. The first of these was a nose-mounted hook for towing the aircraft by car, which allows quicker positioning on the runway. The second modification was stiffening of the nose-gear support by replacing the rear guy wires with steel tubes. This caused the steering to become more sensitive (possibly because the rake was reduced), necessitating adjustments to the steering cable attachment positions. It was also observed that the initial nose-gear bouncing seemed less. Although this was encouraging, it was still so excessive that a means of damping was sought. An initial design involving a "scissors" action with friction pads gave some improvement, but what worked best was the installation of a commercial oil-damped unit (from a small motorcycle) within the strut.

Seven runs were made on 12 October, with the fastest being 40 mph after a 1280 ft acceleration distance. Deceleration required 250 ft. These figures are important because the main runway only allows 7000 ft for the test hop. Another 4 runs were performed on 16 October. Everything went smoothly until 45 mph, at which point three-wheel bouncing occurred. This was the same type of behaviour as encountered on 16 September 1997, although the higher speeds caused the bouncing to be more aggressive. The stabilator positions were varied from zero to negative angles (trailing-edge up), with the negative values aggravating the situation. The only encouraging result was that the thorax and outrigger structures survived these



loads without damage. Upon reviewing the videos of the runs, it was clear that positive stabilator angles (trailing-edge down) should be tried. This occurred on 8 November where, for the first run, 50 mph was readily achieved. Since this is the calculated take-off speed, a nose-up rotation was attempted for the second run. However, in the course of applying this control, the aircraft went into the bouncing mode and damaged the nose-gear. The pilot then throttled back and applied even more nose-up control, in order to keep the nose-gear off the runway as long as possible. At this point the ornithopter lifted off for a full flapping cycle, and only slightly touched down before completing another cycle. After that, the nose strut made contact and scraped along the runway, causing some damage to the supporting nose structure.

Both the data and videos proved to be very valuable for analyzing the sequence of events. What is most evident is that the rotation action must be performed more briskly. That is, the pilot's transition from the positive-angle stabilator position of the acceleration mode to the negative angle for take-off must be done as quickly as possible. The engineering team had always emphasized the need for gradual control motions, and the pilot was acting in accordance with this dictum. However, it is now clear that gradual rotation only allows the aircraft to linger in the dangerous bouncing mode.

The damage was such that the testing was concluded for the year (also, the weather was becoming a factor). Unlike previous years, the task list is fairly short. The main activity is to study the nose gear and supporting structure so that, in addition to performing repairs, appropriate modifications may be made. For example, the sensitive-steering problem might be solved by introducing trail in the nose-gear fork. Also, there is a large quantity of valuable information from the on-board data-acquisition system to be reduced and studied.

CONCLUDING REMARKS

Attention has been focused on developmental issues: what has had to be redesigned and changed as a result of the testing. However, it is only fair to point out what has worked well, holding forth the promise for a flight-worthy aircraft. First of all, with proper functioning of the zero-stage drive, the overall engine/drive-train unit has performed to expectations. At the scale of the full-sized ornithopter this is an unprecedented component, the literal heart of the aircraft. This was able to successfully deliver power through four stages of reduction, with the final stage smoothly converting rotary to oscillatory motion, within the constraints of weight and size required for flight.

Second, the ornithopter has proven to be capable of self-propelling to take-off speeds. As mentioned earlier, because of the lack of information on the wing's thrusting behaviour at speeds below that for full flight, there had been a concern that the leading-edge suction might not build up fast enough during taxiing to allow take-off speed to be attained. As it turns out, the pilot was able to accelerate the aircraft to 50 mph, the calculated take-off value. It is important to note that the issues limiting take-off, to date, appear to have nothing to do with the wing's performance.

Third, the data-acquisition system has been working very well, providing valuable information for the aircraft's development as

well as guiding the test plans. These results will be described in future publications.

When the ornithopter resumes its tests, new problems and developmental issues will, no doubt, become evident. This is normal for any new aircraft, especially one as unique as the ornithopter. However, the most recent taxi trials give encouragement that the project is on the right track to successful flight.

ACKNOWLEDGEMENTS

The nature of this project is such that numerous individuals and organizations donated time, money, or required items. A complete listing of all concerned is given in Reference 12. In the space allowed, though, it is important to acknowledge the key financial donation by the author's research partner, Jeremy M. Harris, which enabled the construction to begin. This was augmented by a National Research Council IRAP (Industrial Research Assistance Program) matching grant, which allowed completion of the aircraft.

REFERENCES

- 1 James D. DeLaurier, "An Aerodynamic Model for Flapping-Wing Flight," *The Aeronautical Journal*, Vol. 97, April 1993, pp. 125-130.
- 2 James D. DeLaurier, "The Development of an Efficient Ornithopter Wing," *The Aeronautical Journal*, Vol. 97, May 1993, pp. 153-162.
- 3 James D. DeLaurier and Jeremy M. Harris, "A Study of Mechanical Flapping-Wing Flight," *The Aeronautical Journal*, Vol. 97, October 1993, pp. 277-286.
- 4 James D. DeLaurier, "An Ornithopter Wing Design", *Canadian Aeronautics and Space Journal*, Vol. 40, No. 1, March 1994, pp. 10-18.
- 5 Rashid, Tahir, "The Flight Dynamics of a Full-Scale Ornithopter", M.A.Sc. Thesis, University of Toronto Institute for Aerospace Studies, 1995.
- 6 Machacek, Todd J., "A Dynamic Analysis and Feasibility Study of a Full-Scale Ornithopter's Take-Off Procedure", M.A.Sc. Thesis, University of Toronto Institute for Aerospace Studies, 1995.
- 7 Fowler, Stuart J., "The Design and Development of a Wing for a Full-Scale Piloted Engine-Powered Flapping-Wing Aircraft (Ornithopter)", M.A.Sc. Thesis, University of Toronto Institute for Aerospace Studies, 1995.
- 8 Mehler, Felix M., "The Structural Testing and Modification of a Full-Scale Ornithopter's Wing Spars", M.A.Sc. Thesis, University of Toronto Institute for Aerospace Studies, 1997.
- 9 Tzembelicos, Constantin, "Designing an Ornithopter Drive-Train", B.A.Sc. Thesis, University of Toronto, Department of Mechanical Engineering, 1994.
- 10 Suppanz, Mark, "Full-Scale Ornithopter Wing Design and Testing", B.A.Sc. Thesis, University of Toronto, Division of Engineering Science, 1994.
- 11 Duffin, James, "Drag Testing of the Ultra-Light Ornithopter", B.A.Sc. Thesis, University of Toronto, Division of Engineering Science, 1995.
- 12 DeLaurier, James D., "A Progress Report on the Development and Testing of a Full-Scale Piloted Ornithopter", 1997, Report No. 355, University of Toronto Institute for Aerospace Studies, May, 1998.