

# Chapter F

## Protection against electric shocks

### Contents

<b>1</b>	<b>General</b>	<b>F2</b>
	1.1 Electric shock	F2
	1.2 Protection against electric shock	F3
	1.3 Direct and indirect contact	F3
<b>2</b>	<b>Protection against direct contact</b>	<b>F4</b>
	2.1 Measures of protection against direct contact	F4
	2.2 Additional measure of protection against direct contact	F6
<b>3</b>	<b>Protection against indirect contact</b>	<b>F6</b>
	3.1 Measures of protection: two levels	F6
	3.2 Automatic disconnection for TT system	F7
	3.3 Automatic disconnection for TN systems	F8
	3.4 Automatic disconnection on a second fault in an IT system	F10
	3.5 Measures of protection against direct or indirect contact without automatic disconnection of supply	F13
<b>4</b>	<b>Protection of goods in case of insulation fault</b>	<b>F17</b>
	4.1 Measures of protection against fire risk with RCDs	F17
	4.2 Ground Fault Protection (GFP)	F17
<b>5</b>	<b>Implementation of the TT system</b>	<b>F19</b>
	5.1 Protective measures	F19
	5.2 Coordination of residual current protective devices	F20
<b>6</b>	<b>Implementation of the TN system</b>	<b>F23</b>
	6.1 Preliminary conditions	F23
	6.2 Protection against indirect contact	F23
	6.3 High-sensitivity RCDs	F27
	6.4 Protection in high fire-risk locations	F28
	6.5 When the fault current-loop impedance is particularly high	F28
<b>7</b>	<b>Implementation of the IT system</b>	<b>F29</b>
	7.1 Preliminary conditions	F29
	7.2 Protection against indirect contact	F30
	7.3 High-sensitivity RCDs	F34
	7.4 Protection in high fire-risk locations	F35
	7.5 When the fault current-loop impedance is particularly high	F35
<b>8</b>	<b>Residual current differential devices (RCDs)</b>	<b>F36</b>
	8.1 Types of RCDs	F36
	8.2 Description	F36
	8.3 Sensitivity of RCDs to disturbances	F39

F1

# 1 General

When a current exceeding 30 mA passes through a part of a human body, the person concerned is in serious danger if the current is not interrupted in a very short time.  
 The protection of persons against electric shock in LV installations must be provided in conformity with appropriate national standards statutory regulations, codes of practice, official guides and circulars etc.  
 Relevant IEC standards include: IEC 60364, IEC 60479 series, IEC 61008, IEC 61009 and IEC 60947-2.

## 1.1 Electric shock

An electric shock is the pathophysiological effect of an electric current through the human body.

Its passage affects essentially the muscular, circulatory and respiratory functions and sometimes results in serious burns. The degree of danger for the victim is a function of the magnitude of the current, the parts of the body through which the current passes, and the duration of current flow.

IEC publication 60479-1 updated in 2005 defines four zones of current-magnitude/ time-duration, in each of which the pathophysiological effects are described (see Fig F1). Any person coming into contact with live metal risks an electric shock.

Curve C1 shows that when a current greater than 30 mA passes through a human being from one hand to feet, the person concerned is likely to be killed, unless the current is interrupted in a relatively short time.

The point 500 ms/100 mA close to the curve C1 corresponds to a probability of heart fibrillation of the order of 0.14%.

The protection of persons against electric shock in LV installations must be provided in conformity with appropriate national standards and statutory regulations, codes of practice, official guides and circulars, etc. Relevant IEC standards include: IEC 60364 series, IEC 60479 series, IEC 60755, IEC 61008 series, IEC 61009 series and IEC 60947-2.

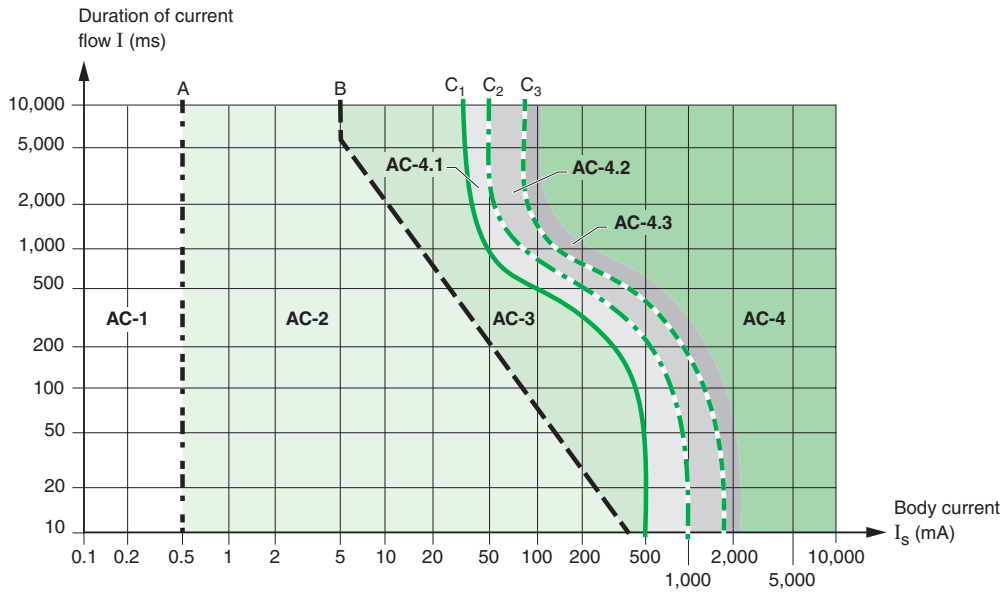

- AC-1 zone: Imperceptible
- AC-2 zone: Perceptible
- AC-3 zone : Reversible effects: muscular contraction
- AC-4 zone: Possibility of irreversible effects
- AC-4-1 zone: Up to 5%probability of heart fibrillation
- AC-4-2 zone: Up to 50% probability of heart fibrillation
- AC-4-3 zone: More than 50% probability of heart fibrillation
- A curve: Threshold of perception of current
- B curve: Threshold of muscular reactions
- C<sub>1</sub> curve: Threshold of 0% probability of ventricular fibrillation
- C<sub>2</sub> curve: Threshold of 5% probability of ventricular fibrillation
- C<sub>3</sub> curve: Threshold of 50% probability of ventricular fibrillation

Fig. F1 : Zones time/current of effects of AC current on human body when passing from left hand to feet

# 1 General

## 1.2 Protection against electric shock

The fundamental rule of protection against electric shock is provided by the document IEC 61140 which covers both electrical installations and electrical equipment.

Hazardous-live-parts shall not be accessible and accessible conductive parts shall not be hazardous.

This requirement needs to apply under:

- Normal conditions, and
- Under a single fault condition

Various measures are adopted to protect against this hazard, and include:

- Automatic disconnection of the power supply to the connected electrical equipment
- Special arrangements such as:
  - The use of class II insulation materials, or an equivalent level of insulation
  - Non-conducting location, out of arm's reach or interposition of barriers
  - Equipotential bonding
  - Electrical separation by means of isolating transformers

F3

## 1.3 Direct and indirect contact

Two measures of protection against direct contact hazards are often required, since, in practice, the first measure may not be infallible

Standards and regulations distinguish two kinds of dangerous contact,

- Direct contact
  - Indirect contact
- and corresponding protective measures

### Direct contact

A direct contact refers to a person coming into contact with a conductor which is live in normal circumstances (see Fig. F2).

IEC 61140 standard has renamed "protection against direct contact" with the term "basic protection". The former name is at least kept for information.

### Indirect contact

An indirect contact refers to a person coming into contact with an exposed-conductive-part which is not normally alive, but has become alive accidentally (due to insulation failure or some other cause).

The fault current raise the exposed-conductive-part to a voltage liable to be hazardous which could be at the origin of a touch current through a person coming into contact with this exposed-conductive-part (see Fig. F3).

IEC 61140 standard has renamed "protection against indirect contact" with the term "fault protection". The former name is at least kept for information.

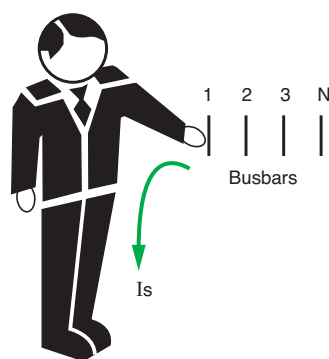

Is: Touch current

Fig. F2 : Direct contact

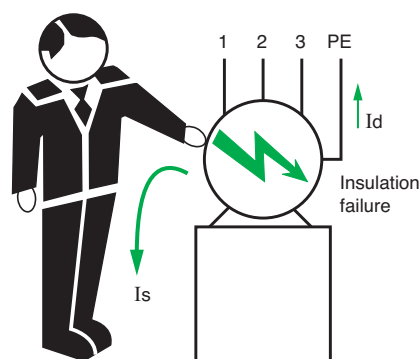

Id: Insulation fault current

Fig F3 : Indirect contact

Two complementary measures are commonly used as protection against the dangers of direct contact:

- The physical prevention of contact with live parts by barriers, insulation, inaccessibility, etc.
- Additional protection in the event that a direct contact occurs, despite or due to failure of the above measures. This protection is based on residual-current operating device with a high sensitivity ( $I\Delta n \leq 30 \text{ mA}$ ) and a low operating time. These devices are highly effective in the majority of case of direct contact.

IEC and national standards frequently distinguish two protections:

- Complete (insulation, enclosures)
- Partial or particular

F4

## 2.1 Measures of protection against direct contact

### Protection by the insulation of live parts

This protection consists of an insulation which complies with the relevant standards (see Fig. F4). Paints, lacquers and varnishes do not provide an adequate protection.

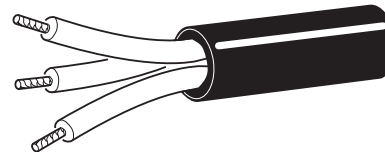

Fig. F4 : Inherent protection against direct contact by insulation of a 3-phase cable with outer sheath

### Protection by means of barriers or enclosures

This measure is in widespread use, since many components and materials are installed in cabinets, assemblies, control panels and distribution boards (see Fig. F5).

To be considered as providing effective protection against direct contact hazards, these equipment must possess a degree of protection equal to at least IP 2X or IP XXB (see chapter E sub-clause 3.4).

Moreover, an opening in an enclosure (door, front panel, drawer, etc.) must only be removable, open or withdrawn:

- By means of a key or tool provided for this purpose, or
- After complete isolation of the live parts in the enclosure, or
- With the automatic interposition of another screen removable only with a key or a tool. The metal enclosure and all metal removable screen must be bonded to the protective earthing conductor of the installation.

### Partial measures of protection

- Protection by means of obstacles, or by placing out of arm's reach

This protection is reserved only to locations to which skilled or instructed persons only have access. The erection of this protective measure is detailed in IEC 60364-4-41.

### Particular measures of protection

- Protection by use of extra-low voltage SELV (Safety Extra-Low Voltage) or by limitation of the energy of discharge.

These measures are used only in low-power circuits, and in particular circumstances, as described in section 3.5.



Fig. F5 : Example of isolation by envelope

## 2 Protection against direct contact

An additional measure of protection against the hazards of direct contact is provided by the use of residual current operating device, which operate at 30 mA or less, and are referred to as RCDs of high sensitivity

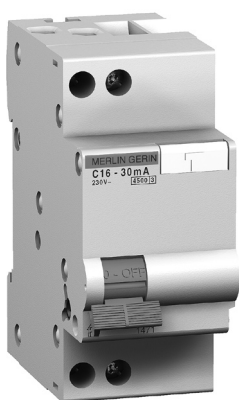

Fig. F6 : High sensitivity RCD

### 2.2 Additional measure of protection against direct contact

All the preceding protective measures are preventive, but experience has shown that for various reasons they cannot be regarded as being infallible. Among these reasons may be cited:

- Lack of proper maintenance
- Imprudence, carelessness
- Normal (or abnormal) wear and tear of insulation; for instance flexure and abrasion of connecting leads
- Accidental contact
- Immersion in water, etc. A situation in which insulation is no longer effective

In order to protect users in such circumstances, highly sensitive fast tripping devices, based on the detection of residual currents to earth (which may or may not be through a human being or animal) are used to disconnect the power supply automatically, and with sufficient rapidity to prevent injury to, or death by electrocution, of a normally healthy human being (see Fig. F6).

These devices operate on the principle of differential current measurement, in which any difference between the current entering a circuit and that leaving it (on a system supplied from an earthed source) be flowing to earth, either through faulty insulation or through contact of an earthed part, such as a person, with a live conductor.

Standardised residual-current devices, referred to as RCDs, sufficiently sensitive for protection against direct contact are rated at 30 mA of differential current.

According to IEC 60364-4-41, additional protection by means of high sensitivity RCDs ( $I_n \leq 30$  mA) must be provided for circuits supplying socket-outlets with a rated current  $\leq 20$  A in all locations, and for circuits supplying mobile equipment with a rated current  $\leq 32$  A for use outdoors.

This additional protection is required in certain countries for circuits supplying socket-outlets rated up to 32 A, and even higher if the location is wet and/or temporary (such as work sites for instance).

It is also recommended to limit the number of socket-outlets protected by a RCD (e.g. 10 socket-outlets for one RCD).

Chapter P section 3 itemises various common locations in which RCDs of high sensitivity are obligatory (in some countries), but in any case, are highly recommended as an effective protection against both direct and indirect contact hazards.

F5

# 3 Protection against indirect contact

Exposed-conductive-parts used in the manufacturing process of an electrical equipment is separated from the live parts of the equipment by the "basic insulation". Failure of the basic insulation will result in the exposed-conductive-parts being alive.

Touching a normally dead part of an electrical equipment which has become live due to the failure of its insulation, is referred to as an indirect contact.

## 3.1 Measures of protection: two levels

Two levels of protective measures exist:

- 1<sup>st</sup> level: The earthing of all exposed-conductive-parts of electrical equipment in the installation and the constitution of an equipotential bonding network (see chapter G section 6).
- 2<sup>nd</sup> level: Automatic disconnection of the supply of the section of the installation concerned, in such a way that the touch-voltage/time safety requirements are respected for any level of touch voltage  $U_c^{(1)}$  (see Fig. F7).

Protection against indirect contact hazards can be achieved by automatic disconnection of the supply if the exposed-conductive-parts of equipment are properly earthed

F6

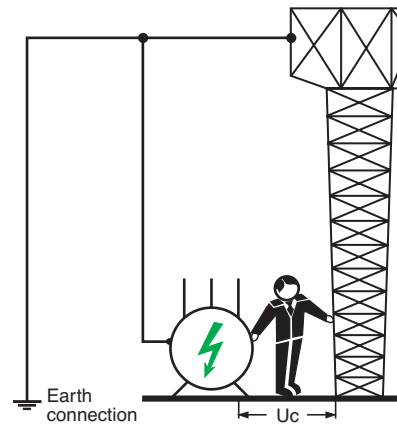

Fig. F7 : Illustration of the dangerous touch voltage  $U_c$

The greater the value of  $U_c$ , the greater the rapidity of supply disconnection required to provide protection (see Fig. F8). The highest value of  $U_c$  that can be tolerated indefinitely without danger to human beings is 50 V CA.

### Reminder of the theoretical disconnecting-time limits

$U_o$ (V)	$50 < U_o \leq 120$	$120 < U_o \leq 230$	$230 < U_o \leq 400$	$U_o > 400$
System TN or IT	0.8	0.4	0.2	0.1
TT	0.3	0.2	0.07	0.04

Fig. F8 : Maximum safe duration of the assumed values of AC touch voltage (in seconds)

(1) Touch voltage  $U_c$  is the voltage existing (as the result of insulation failure) between an exposed-conductive-part and any conductive element within reach which is at a different (generally earth) potential.

# 3 Protection against indirect contact

## 3.2 Automatic disconnection for TT system

Automatic disconnection for TT system is achieved by RCD having a sensitivity of  $I_{\Delta n} \leq \frac{50}{R_A}$  where  $R_A$  is the resistance of the installation earth electrode

### Principle

In this system all exposed-conductive-parts and extraneous-conductive-parts of the installation must be connected to a common earth electrode. The neutral point of the supply system is normally earthed at a point outside the influence area of the installation earth electrode, but need not be so. The impedance of the earth-fault loop therefore consists mainly in the two earth electrodes (i.e. the source and installation electrodes) in series, so that the magnitude of the earth fault current is generally too small to operate overcurrent relay or fuses, and the use of a residual current operated device is essential.

This principle of protection is also valid if one common earth electrode only is used, notably in the case of a consumer-type substation within the installation area, where space limitation may impose the adoption of a TN system earthing, but where all other conditions required by the TN system cannot be fulfilled.

Protection by automatic disconnection of the supply used in TT system is by RCD of sensitivity:  $I_{\Delta n} \leq \frac{50}{R_A}$

where

$R_A$  is the resistance of the earth electrode for the installation

$I_{\Delta n}$  is the rated residual operating current of the RCD

For temporary supplies (to work sites, ...) and agricultural and horticultural premises, the value of 50 V is replaced by 25 V.

### Example (see Fig. F9)

- The resistance of the earth electrode of substation neutral  $R_n$  is 10  $\Omega$ .
- The resistance of the earth electrode of the installation  $R_A$  is 20  $\Omega$ .
- The earth-fault loop current  $I_d = 7.7$  A.
- The fault voltage  $U_f = I_d \times R_A = 154$  V and therefore dangerous, but  $I_{\Delta n} = 50/20 = 2.5$  A so that a standard 300 mA RCD will operate in about 30 ms without intentional time delay and will clear the fault where a fault voltage exceeding appears on an exposed-conductive-part.

F7

$U_0^{(1)}$ (V)	T (s)
$50 < U_0 \leq 120$	0.3
$120 < U_0 \leq 230$	0.2
$230 < U_0 \leq 400$	0.07
$U_0 > 400$	0.04

(1)  $U_0$  is the nominal phase to earth voltage

Fig. F10 : Maximum disconnecting time for AC final circuits not exceeding 32 A

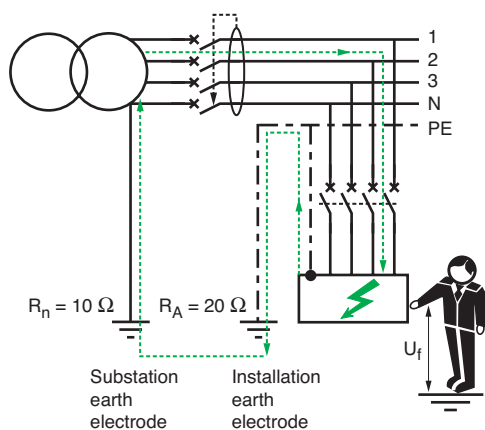

Fig. F9 : Automatic disconnection of supply for TT system

### Specified maximum disconnection time

The tripping times of RCDs are generally lower than those required in the majority of national standards; this feature facilitates their use and allows the adoption of an effective discriminative protection.

The IEC 60364-4-41 specifies the maximum operating time of protective devices used in TT system for the protection against indirect contact:

- For all final circuits with a rated current not exceeding 32 A, the maximum disconnecting time will not exceed the values indicated in **Figure F10**
  - For all other circuits, the maximum disconnecting time is fixed to 1s. This limit enables discrimination between RCDs when installed on distribution circuits.
- RCD is a general term for all devices operating on the residual-current principle. RCCB (Residual Current Circuit-Breaker) as defined in IEC 61008 series is a specific class of RCD.

Type G (general) and type S (Selective) of IEC 61008 have a tripping time/current characteristics as shown in **Figure F11** next page. These characteristics allow a certain degree of selective tripping between the several combination of ratings and types, as shown later in sub-clause 4.3. Industrial type RCD according to IEC 60947-2 provide more possibilities of discrimination due to their flexibility of time-delaying.

$\times I_{\Delta n}$		1	2	5	> 5
Domestic	Instantaneous	0.3	0.15	0.04	0.04
	Type S	0.5	0.2	0.15	0.15
Industrial	Instantaneous	0.3	0.15	0.04	0.04
	Time-delay (0.06)	0.5	0.2	0.15	0.15
	Time-delay (other)	According to manufacturer			

Fig. F11 : Maximum operating time of RCD's (in seconds)

F8

The automatic disconnection for TN system is achieved by overcurrent protective devices or RCD's

### 3.3 Automatic disconnection for TN systems

#### Principle

In this system all exposed and extraneous-conductive-parts of the installation are connected directly to the earthed point of the power supply by protective conductors. As noted in Chapter E Sub-clause 1.2, the way in which this direct connection is carried out depends on whether the TN-C, TN-S, or TN-C-S method of implementing the TN principle is used. In figure F12 the method TN-C is shown, in which the neutral conductor acts as both the Protective-Earth and Neutral (PEN) conductor. In all TN systems, any insulation fault to earth results in a phase to neutral short-circuit. High fault current levels allow to use overcurrent protection but can give rise to touch voltages exceeding 50% of the phase to neutral voltage at the fault position during the short disconnection time.

In practice for utility distribution network, earth electrodes are normally installed at regular intervals along the protective conductor (PE or PEN) of the network, while the consumer is often required to install an earth electrode at the service entrance.

On large installations additional earth electrodes dispersed around the premises are often provided, in order to reduce the touch voltage as much as possible. In high-rise apartment blocks, all extraneous conductive parts are connected to the protective conductor at each level. In order to ensure adequate protection, the earth-fault current

$$I_d = \frac{U_o}{Z_s} \text{ or } 0.8 \frac{U_o}{Z_c} \text{ must be higher or equal to } I_a, \text{ where:}$$

- $U_o$  = nominal phase to neutral voltage
- $I_d$  = the fault current
- $I_a$  = current equal to the value required to operate the protective device in the time specified
- $Z_s$  = earth-fault current loop impedance, equal to the sum of the impedances of the source, the live phase conductors to the fault position, the protective conductors from the fault position back to the source
- $Z_c$  = the faulty-circuit loop impedance (see "conventional method" Sub-clause 6.2)

**Note:** The path through earth electrodes back to the source will have (generally) much higher impedance values than those listed above, and need not be considered.

#### Example (see Fig. F12)

The fault voltage  $U_f = \frac{230}{2} = 115 \text{ V}$  and is hazardous;

The fault loop impedance  $Z_s = Z_{AB} + Z_{BC} + Z_{DE} + Z_{EN} + Z_{NA}$ .

If  $Z_{BC}$  and  $Z_{DE}$  are predominant, then:

$$Z_s = 2\rho \frac{L}{S} = 64.3 \text{ m}\Omega, \text{ so that}$$

$$I_d = \frac{230}{64.3 \times 10^{-3}} = 3,576 \text{ A } (\approx 22 \text{ In based on a NSX160 circuit-breaker}).$$

The "instantaneous" magnetic trip unit adjustment of the circuit-breaker is many times less than this short-circuit value, so that positive operation in the shortest possible time is assured.

**Note:** Some authorities base such calculations on the assumption that a voltage drop of 20% occurs in the part of the impedance loop BANE.

This method, which is recommended, is explained in chapter F sub-clause 6.2 "conventional method" and in this example will give an estimated fault current of  $\frac{230 \times 0.8 \times 10^3}{64.3} = 2,816 \text{ A } (\approx 18 \text{ In}).$

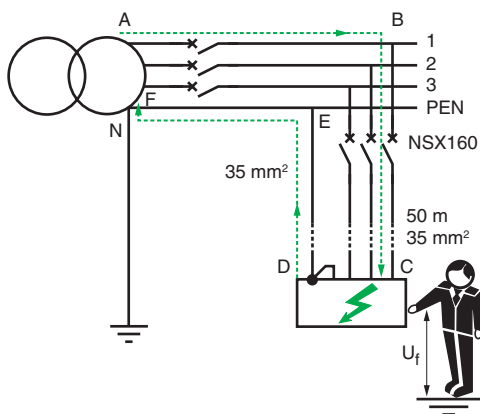

Fig. F12 : Automatic disconnection in TN system



# 3 Protection against indirect contact

## Specified maximum disconnection time

The IEC 60364-4-41 specifies the maximum operating time of protective devices used in TN system for the protection against indirect contact:

- For all final circuits with a rated current not exceeding 32 A, the maximum disconnecting time will not exceed the values indicated in **Figure F13**
- For all other circuits, the maximum disconnecting time is fixed to 5s. This limit enables discrimination between protective devices installed on distribution circuits

**Note:** The use of RCDs may be necessary on TN-earthed systems. Use of RCDs on TN-C-S systems means that the protective conductor and the neutral conductor must (evidently) be separated upstream of the RCD. This separation is commonly made at the service entrance.

$U_o^{(1)}$ (V)	T (s)
$50 < U_o \leq 120$	0.8
$120 < U_o \leq 230$	0.4
$230 < U_o \leq 400$	0.2
$U_o > 400$	0.1

(1)  $U_o$  is the nominal phase to earth voltage

F9

Fig. F13 : Maximum disconnecting time for AC final circuits not exceeding 32 A

If the protection is to be provided by a circuit-breaker, it is sufficient to verify that the fault current will always exceed the current-setting level of the instantaneous or short-time delay tripping unit ( $I_m$ )

## Protection by means of circuit-breaker (see Fig. F14)

The instantaneous trip unit of a circuit-breaker will eliminate a short-circuit to earth in less than 0.1 second.

In consequence, automatic disconnection within the maximum allowable time will always be assured, since all types of trip unit, magnetic or electronic, instantaneous or slightly retarded, are suitable:  $I_a = I_m$ . The maximum tolerance authorised by the relevant standard, however, must always be taken into consideration. It is sufficient therefore that the fault current  $\frac{U_o}{Z_s}$  or  $0.8 \frac{U_o}{Z_c}$  determined by calculation (or estimated on site) be greater than the instantaneous trip-setting current, or than the very short-time tripping threshold level, to be sure of tripping within the permitted time limit.

$I_a$  can be determined from the fuse performance curve. In any case, protection cannot be achieved if the loop impedance  $Z_s$  or  $Z_c$  exceeds a certain value

## Protection by means of fuses (see Fig. F15)

The value of current which assures the correct operation of a fuse can be ascertained from a current/time performance graph for the fuse concerned.

The fault current  $\frac{U_o}{Z_s}$  or  $0.8 \frac{U_o}{Z_c}$  as determined above, must largely exceed that necessary to ensure positive operation of the fuse. The condition to observe therefore is that  $I_a < \frac{U_o}{Z_s}$  or  $0.8 \frac{U_o}{Z_c}$  as indicated in Figure F15.

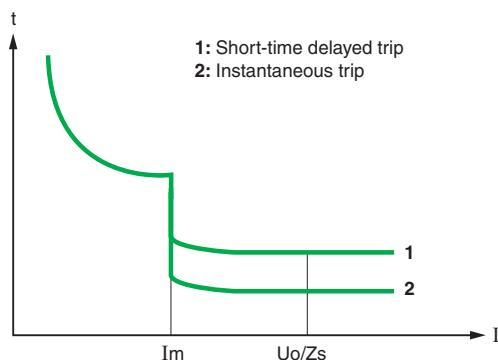

Fig. F14 : Disconnection by circuit-breaker for a TN system

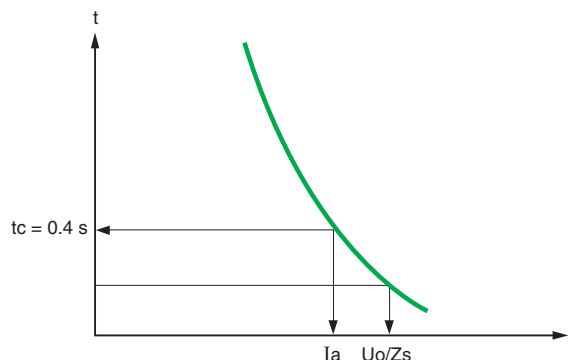

Fig. F15 : Disconnection by fuses for a TN system

F10

**Example:** The nominal phase to neutral voltage of the network is 230 V and the maximum disconnection time given by the graph in Figure F15 is 0.4 s. The corresponding value of  $I_a$  can be read from the graph. Using the voltage (230 V) and the current  $I_a$ , the complete loop impedance or the circuit loop impedance can be calculated from  $Z_s = \frac{230}{I_a}$  or  $Z_c = 0.8 \frac{230}{I_a}$ . This impedance value must never be exceeded and should preferably be substantially less to ensure satisfactory fuse operation.

**Protection by means of Residual Current Devices for TN-S circuits**

Residual Current Devices must be used where:

- The loop impedance cannot be determined precisely (lengths difficult to estimate, presence of metallic material close to the wiring)
- The fault current is so low that the disconnecting time cannot be met by using overcurrent protective devices

The rated tripping current of RCDs being in the order of a few amps, it is well below the fault current level. RCDs are consequently well adapted to this situation.

In practice, they are often installed in the LV sub distribution and in many countries, the automatic disconnection of final circuits shall be achieved by Residual Current Devices.

**3.4 Automatic disconnection on a second fault in an IT system**

In this type of system:

- The installation is isolated from earth, or the neutral point of its power-supply source is connected to earth through a high impedance
- All exposed and extraneous-conductive-parts are earthed via an installation earth electrode.

**First fault situation**

On the occurrence of a true fault to earth, referred to as a “first fault”, the fault current is very low, such that the rule  $I_d \times R_A \leq 50 \text{ V}$  (see F3.2) is fulfilled and no dangerous fault voltages can occur.

In practice the current  $I_d$  is low, a condition that is neither dangerous to personnel, nor harmful to the installation.

However, in this system:

- A permanent monitoring of the insulation to earth must be provided, coupled with an alarm signal (audio and/or flashing lights, etc.) operating in the event of a first earth fault (see Fig. F16)
- The rapid location and repair of a first fault is imperative if the full benefits of the IT system are to be realised. Continuity of service is the great advantage afforded by the system.

For a network formed from 1 km of new conductors, the leakage (capacitive) impedance to earth  $Z_f$  is of the order of 3,500  $\Omega$  per phase. In normal operation, the capacitive current<sup>(1)</sup> to earth is therefore:

$$\frac{U_0}{Z_f} = \frac{230}{3,500} = 66 \text{ mA per phase.}$$

During a phase to earth fault, as indicated in Figure F17 opposite page, the current passing through the electrode resistance  $R_{nA}$  is the vector sum of the capacitive currents in the two healthy phases. The voltages of the healthy phases have (because of the fault) increased to  $\sqrt{3}$  the normal phase voltage, so that the capacitive currents increase by the same amount. These currents are displaced, one from the other by 60°, so that when added vectorially, this amounts to  $3 \times 66 \text{ mA} = 198 \text{ mA}$ , in the present example.

The fault voltage  $U_f$  is therefore equal to  $198 \times 5 \times 10^{-3} = 0.99 \text{ V}$ , which is obviously harmless.

The current through the short-circuit to earth is given by the vector sum of the neutral-resistor current  $I_{d1}$  (=153 mA) and the capacitive current  $I_{d2}$  (198 mA).

Since the exposed-conductive-parts of the installation are connected directly to earth, the neutral impedance  $Z_{ct}$  plays practically no part in the production of touch voltages to earth.

*In IT system the first fault to earth should not cause any disconnection*



**Fig. F16 :** Phases to earth insulation monitoring device obligatory in IT system

(1) Resistive leakage current to earth through the insulation is assumed to be negligibly small in the example.

### 3 Protection against indirect contact

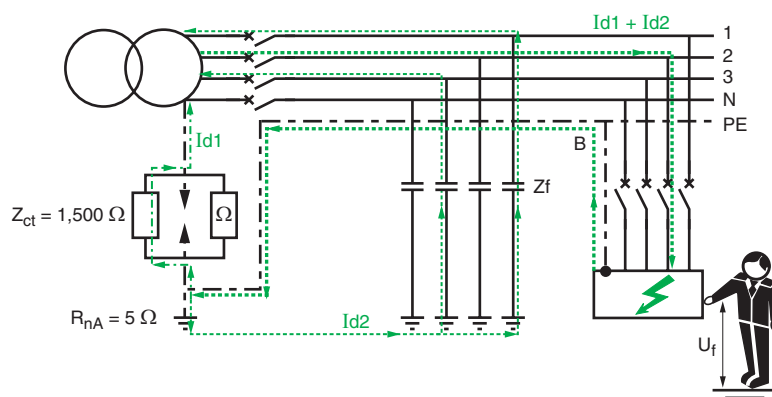

Fig. F17 : Fault current path for a first fault in IT system

F11

*The simultaneous existence of two earth faults (if not both on the same phase) is dangerous, and rapid clearance by fuses or automatic circuit-breaker tripping depends on the type of earth-bonding scheme, and whether separate earthing electrodes are used or not, in the installation concerned*

#### Second fault situation

On the appearance of a second fault, on a different phase, or on a neutral conductor, a rapid disconnection becomes imperative. Fault clearance is carried out differently in each of the following cases:

##### 1<sup>st</sup> case

It concerns an installation in which all exposed conductive parts are bonded to a common PE conductor, as shown in Figure F18.

In this case no earth electrodes are included in the fault current path, so that a high level of fault current is assured, and conventional overcurrent protective devices are used, i.e. circuit-breakers and fuses.

The first fault could occur at the end of a circuit in a remote part of the installation, while the second fault could feasibly be located at the opposite end of the installation.

For this reason, it is conventional to double the loop impedance of a circuit, when calculating the anticipated fault setting level for its overcurrent protective device(s).

Where the system includes a neutral conductor in addition to the 3 phase conductors, the lowest short-circuit fault currents will occur if one of the (two) faults is from the neutral conductor to earth (all four conductors are insulated from earth in an IT scheme). In four-wire IT installations, therefore, the phase-to-neutral voltage must be used to calculate short-circuit protective levels i.e.  $0.8 \frac{U_0}{2 Z_c} \geq I_a^{(1)}$  where

$U_0$  = phase to neutral voltage

$Z_c$  = impedance of the circuit fault-current loop (see F3.3)

$I_a$  = current level for trip setting

If no neutral conductor is distributed, then the voltage to use for the fault-current calculation is the phase-to-phase value, i.e.  $0.8 \frac{\sqrt{3} U_0}{2 Z_c} \geq I_a^{(1)}$

##### ■ Maximum tripping times

Disconnecting times for IT system depends on how the different installation and substation earth electrodes are interconnected.

For final circuits supplying electrical equipment with a rated current not exceeding 32 A and having their exposed-conductive-parts bonded with the substation earth electrode, the maximum tripping time is given in table F8. For the other circuits within the same group of interconnected exposed-conductive-parts, the maximum disconnecting time is 5 s. This is due to the fact that any double fault situation within this group will result in a short-circuit current as in TN system.

For final circuits supplying electrical equipment with a rated current not exceeding 32 A and having their exposed-conductive-parts connected to an independent earth electrode electrically separated from the substation earth electrode, the maximum tripping time is given in Figure F13. For the other circuits within the same group of non interconnected exposed-conductive-parts, the maximum disconnecting time is 1s. This is due to the fact that any double fault situation resulting from one insulation fault within this group and another insulation fault from another group will generate a fault current limited by the different earth electrode resistances as in TT system.

(1) Based on the "conventional method" noted in the first example of Sub-clause 3.3.

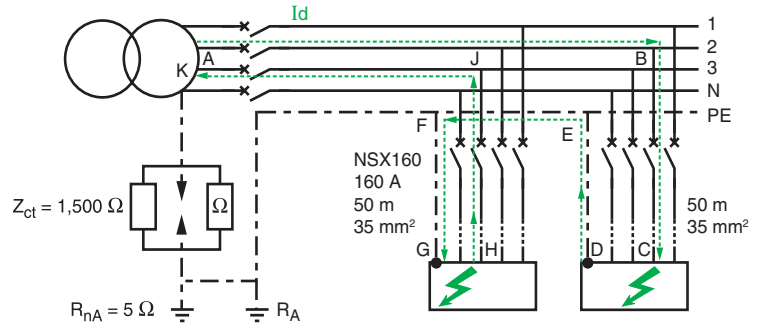

Fig. F18 : Circuit-breaker tripping on double fault situation when exposed-conductive-parts are connected to a common protective conductor

F12

■ Protection by circuit-breaker

In the case shown in Figure F18, the adjustments of instantaneous and short-time delay overcurrent trip unit must be decided. The times recommended here above can be readily complied with. The short-circuit protection provided by the NSX160 circuit-breaker is suitable to clear a phase to phase short-circuit occurring at the load ends of the circuits concerned.

Reminder: In an IT system, the two circuits involved in a phase to phase short-circuit are assumed to be of equal length, with the same cross sectional area conductors, the PE conductors being the same cross sectional area as the phase conductors. In such a case, the impedance of the circuit loop when using the “conventional method” (sub clause 6.2) will be twice that calculated for one of the circuits in the TN case, shown in Chapter F sub clause 3.3.

The resistance of circuit loop  $FGHJ = 2R_{JH} = 2\rho \frac{L}{a}$  in  $m\Omega$  where:

$\rho$  = resistance of copper rod 1 meter long of cross sectional area  $1\text{ mm}^2$ , in  $m\Omega$

$L$  = length of the circuit in meters

$a$  = cross sectional area of the conductor in  $\text{mm}^2$

$FGHJ = 2 \times 22.5 \times 50/35 = 64.3\text{ m}\Omega$

and the loop resistance B, C, D, E, F, G, H, J will be  $2 \times 64.3 = 129\text{ m}\Omega$ .

The fault current will therefore be  $0.8 \times \sqrt{3} \times 230 \times 10^3/129 = 2,470\text{ A}$ .

■ Protection by fuses

The current  $I_a$  for which fuse operation must be assured in a time specified according to here above can be found from fuse operating curves, as described in figure F15.

The current indicated should be significantly lower than the fault currents calculated for the circuit concerned.

■ Protection by Residual current circuit-breakers (RCCBs)

For low values of short-circuit current, RCCBs are necessary. Protection against indirect contact hazards can be achieved then by using one RCCB for each circuit.

2<sup>nd</sup> case

■ It concerns exposed conductive parts which are earthed either individually (each part having its own earth electrode) or in separate groups (one electrode for each group).

If all exposed conductive parts are not bonded to a common electrode system, then it is possible for the second earth fault to occur in a different group or in a separately earthed individual apparatus. Additional protection to that described above for case 1, is required, and consists of a RCD placed at the circuit-breaker controlling each group and each individually-earthed apparatus.

### 3 Protection against indirect contact

The reason for this requirement is that the separate-group electrodes are “bonded” through the earth so that the phase to phase short-circuit current will generally be limited when passing through the earth bond by the electrode contact resistances with the earth, thereby making protection by overcurrent devices unreliable. The more sensitive RCDs are therefore necessary, but the operating current of the RCDs must evidently exceed that which occurs for a first fault (see Fig. F19).

Leakage capacitance (μF)	First fault current (A)
1	0.07
5	0.36
30	2.17

**Note:** 1 μF is the 1 km typical leakage capacitance for 4-conductor cable.

Fig. F19 : Correspondence between the earth leakage capacitance and the first fault current

For a second fault occurring within a group having a common earth-electrode system, the overcurrent protection operates, as described above for case 1.

**Note 1:** See also Chapter G Sub-clause 7.2, protection of the neutral conductor.

**Note 2:** In 3-phase 4-wire installations, protection against overcurrent in the neutral conductor is sometimes more conveniently achieved by using a ring-type current transformer over the single-core neutral conductor (see Fig. F20).

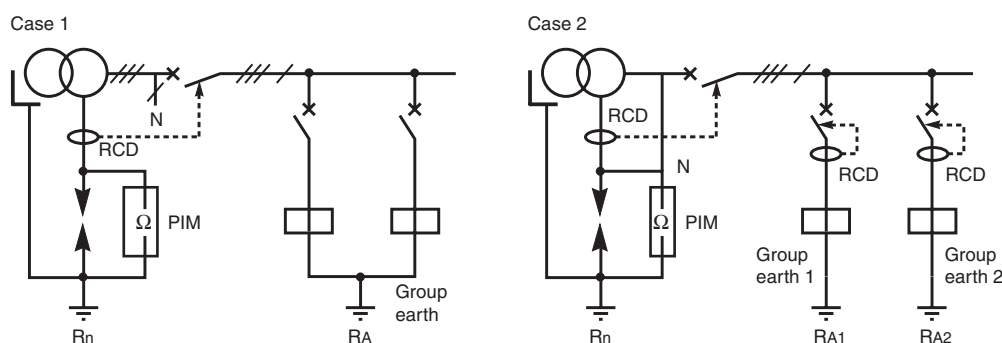

Fig. F20 : Application of RCDs when exposed-conductive-parts are earthed individually or by group on IT system

### 3.5 Measures of protection against direct or indirect contact without automatic disconnection of supply

#### The use of SELV (Safety Extra-Low Voltage)

Safety by extra low voltage SELV is used in situations where the operation of electrical equipment presents a serious hazard (swimming pools, amusement parks, etc.). This measure depends on supplying power at extra-low voltage from the secondary windings of isolating transformers especially designed according to national or to international (IEC 60742) standard. The impulse withstand level of insulation between the primary and secondary windings is very high, and/or an earthed metal screen is sometimes incorporated between the windings. The secondary voltage never exceeds 50 V rms.

Three conditions of exploitation must be respected in order to provide satisfactory protection against indirect contact:

- No live conductor at SELV must be connected to earth
- Exposed-conductive-parts of SELV supplied equipment must not be connected to earth, to other exposed conductive parts, or to extraneous-conductive-parts
- All live parts of SELV circuits and of other circuits of higher voltage must be separated by a distance at least equal to that between the primary and secondary windings of a safety isolating transformer.

Extra-low voltage is used where the risks are great: swimming pools, wandering-lead hand lamps, and other portable appliances for outdoor use, etc.

F14

These measures require that:

- SELV circuits must use conduits exclusively provided for them, unless cables which are insulated for the highest voltage of the other circuits are used for the SELV circuits
- Socket outlets for the SELV system must not have an earth-pin contact. The SELV circuit plugs and sockets must be special, so that inadvertent connection to a different voltage level is not possible.

**Note:** In normal conditions, when the SELV voltage is less than 25 V, there is no need to provide protection against direct contact hazards. Particular requirements are indicated in Chapter P, Clause 3: "special locations".

**The use of PELV (Protection by Extra Low Voltage)** (see Fig. F21)

This system is for general use where low voltage is required, or preferred for safety reasons, other than in the high-risk locations noted above. The conception is similar to that of the SELV system, but the secondary circuit is earthed at one point.

IEC 60364-4-41 defines precisely the significance of the reference PELV. Protection against direct contact hazards is generally necessary, except when the equipment is in the zone of equipotential bonding, and the nominal voltage does not exceed 25 V rms, and the equipment is used in normally dry locations only, and large-area contact with the human body is not expected. In all other cases, 6 V rms is the maximum permitted voltage, where no direct contact protection is provided.

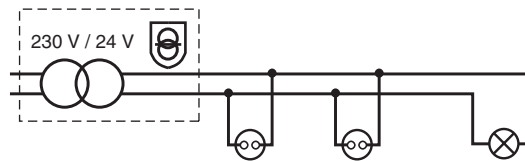

Fig. F21 : Low-voltage supplies from a safety isolating transformer

**FELV system (Functional Extra-Low Voltage)**

Where, for functional reasons, a voltage of 50 V or less is used, but not all of the requirements relating to SELV or PELV are fulfilled, appropriate measures described in IEC 60364-4-41 must be taken to ensure protection against both direct and indirect contact hazards, according to the location and use of these circuits.

**Note:** Such conditions may, for example, be encountered when the circuit contains equipment (such as transformers, relays, remote-control switches, contactors) insufficiently insulated with respect to circuits at higher voltages.

**The electrical separation of circuits** (see Fig. F22)

The principle of the electrical separation of circuits (generally single-phase circuits) for safety purposes is based on the following rationale.

The two conductors from the unearthed single-phase secondary winding of a separation transformer are insulated from earth.

If a direct contact is made with one conductor, a very small current only will flow into the person making contact, through the earth and back to the other conductor, via the inherent capacitance of that conductor with respect to earth. Since the conductor capacitance to earth is very small, the current is generally below the level of perception. As the length of circuit cable increases, the direct contact current will progressively increase to a point where a dangerous electric shock will be experienced.

Even if a short length of cable precludes any danger from capacitive current, a low value of insulation resistance with respect to earth can result in danger, since the current path is then via the person making contact, through the earth and back to the other conductor through the low conductor-to-earth insulation resistance.

For these reasons, relatively short lengths of well insulated cables are essential in separation systems.

Transformers are specially designed for this duty, with a high degree of insulation between primary and secondary windings, or with equivalent protection, such as an earthed metal screen between the windings. Construction of the transformer is to class II insulation standards.

*The electrical separation of circuits is suitable for relatively short cable lengths and high levels of insulation resistance. It is preferably used for an individual appliance*

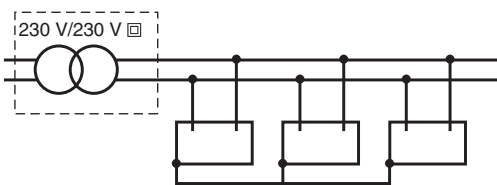

Fig. F22 : Safety supply from a class II separation transformer

## 3 Protection against indirect contact

As indicated before, successful exploitation of the principle requires that:

- No conductor or exposed conductive part of the secondary circuit must be connected to earth,
- The length of secondary cabling must be limited to avoid large capacitance values<sup>(1)</sup>,
- A high insulation-resistance value must be maintained for the cabling and appliances. These conditions generally limit the application of this safety measure to an individual appliance.

In the case where several appliances are supplied from a separation transformer, it is necessary to observe the following requirements:

- The exposed conductive parts of all appliances must be connected together by an insulated protective conductor, but not connected to earth,
- The socket outlets must be provided with an earth-pin connection. The earth-pin connection is used in this case only to ensure the interconnection (bonding) of all exposed conductive parts.

In the case of a second fault, overcurrent protection must provide automatic disconnection in the same conditions as those required for an IT system of power system earthing.

Class II equipment symbol:



### Class II equipment

These appliances are also referred to as having “double insulation” since in class II appliances a supplementary insulation is added to the basic insulation (see Fig. F23).

No conductive parts of a class II appliance must be connected to a protective conductor:

- Most portable or semi-fixed equipment, certain lamps, and some types of transformer are designed to have double insulation. It is important to take particular care in the exploitation of class II equipment and to verify regularly and often that the class II standard is maintained (no broken outer envelope, etc.). Electronic devices, radio and television sets have safety levels equivalent to class II, but are not formally class II appliances
- Supplementary insulation in an electrical installation: IEC 60364-4-41 (Sub-clause 413-2) and some national standards such as NF C 15-100 (France) describe in more detail the necessary measures to achieve the supplementary insulation during installation work.

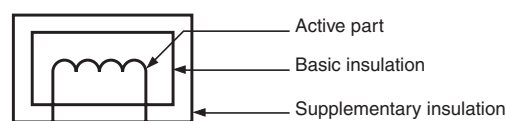

Fig. F23 : Principle of class II insulation level

A simple example is that of drawing a cable into a PVC conduit. Methods are also described for distribution switchboards.

- For distribution switchboards and similar equipment, IEC 60439-1 describes a set of requirements, for what is referred to as “total insulation”, equivalent to class II
- Some cables are recognised as being equivalent to class II by many national standards

*In principle, safety by placing simultaneously-accessible conductive parts out-of-reach, or by interposing obstacles, requires also a non-conducting floor, and so is not an easily applied principle*

### Out-of-arm's reach or interposition of obstacles

By these means, the probability of touching a live exposed-conductive-part, while at the same time touching an extraneous-conductive-part at earth potential, is extremely low (see Fig. F24 next page). In practice, this measure can only be applied in a dry location, and is implemented according to the following conditions:

- The floor and the wall of the chamber must be non-conducting, i.e. the resistance to earth at any point must be:
  - > 50 k $\Omega$  (installation voltage  $\leq$  500 V)
  - > 100 k $\Omega$  (500 V < installation voltage  $\leq$  1000 V)

Resistance is measured by means of “MEGGER” type instruments (hand-operated generator or battery-operated electronic model) between an electrode placed on the floor or against the wall, and earth (i.e. the nearest protective earth conductor). The electrode contact area pressure must be evidently be the same for all tests.

Different instruments suppliers provide electrodes specific to their own product, so that care should be taken to ensure that the electrodes used are those supplied with the instrument.

(1) It is recommended in IEC 364-4-41 that the product of the nominal voltage of the circuit in volts and length in metres of the wiring system should not exceed 100,000, and that the length of the wiring system should not exceed 500 m.

### 3 Protection against indirect contact

- The placing of equipment and obstacles must be such that simultaneous contact with two exposed-conductive-parts or with an exposed conductive-part and an extraneous-conductive-part by an individual person is not possible.
- No exposed protective conductor must be introduced into the chamber concerned.
- Entrances to the chamber must be arranged so that persons entering are not at risk, e.g. a person standing on a conducting floor outside the chamber must not be able to reach through the doorway to touch an exposed-conductive-part, such as a lighting switch mounted in an industrial-type cast-iron conduit box, for example.

F16

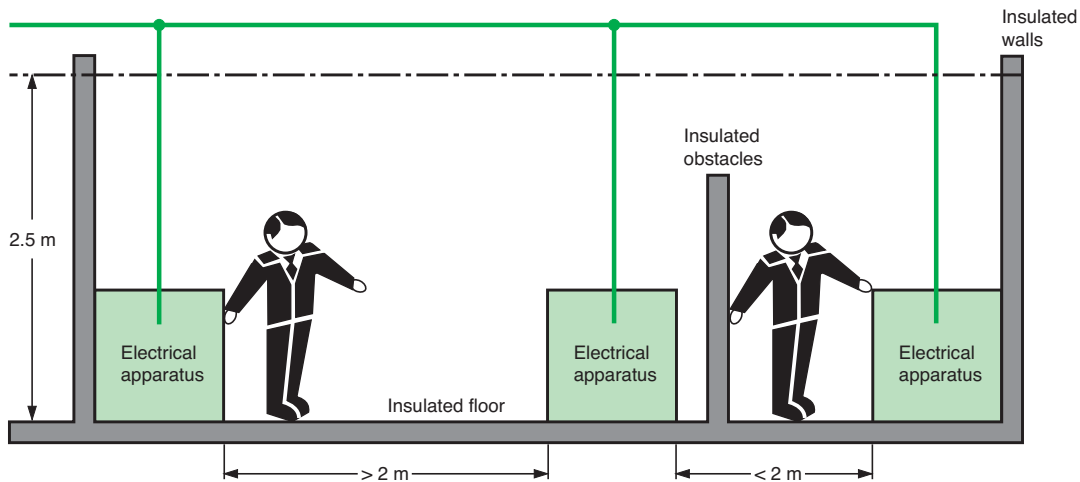

Fig. F24 : Protection by out-of arm's reach arrangements and the interposition of non-conducting obstacles

Earth-free equipotential chambers are associated with particular installations (laboratories, etc.) and give rise to a number of practical installation difficulties

#### Earth-free equipotential chambers

In this scheme, all exposed-conductive-parts, including the floor<sup>(1)</sup> are bonded by suitably large conductors, such that no significant difference of potential can exist between any two points. A failure of insulation between a live conductor and the metal envelope of an appliance will result in the whole "cage" being raised to phase-to-earth voltage, but no fault current will flow. In such conditions, a person entering the chamber would be at risk (since he/she would be stepping on to a live floor).

Suitable precautions must be taken to protect personnel from this danger (e.g. non-conducting floor at entrances, etc.). Special protective devices are also necessary to detect insulation failure, in the absence of significant fault current.

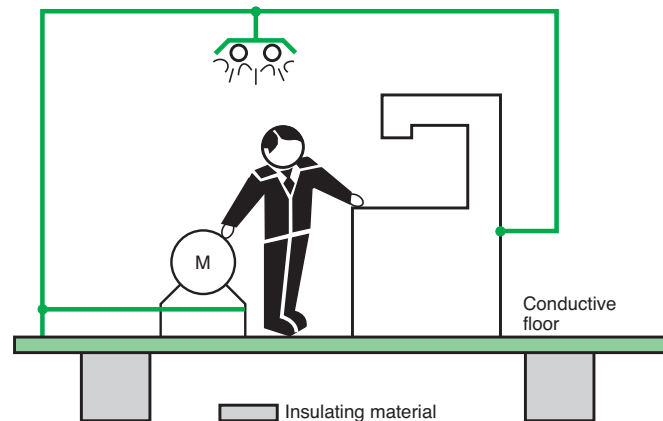

Fig. F25 : Equipotential bonding of all exposed-conductive-parts simultaneously accessible

(1) Extraneous conductive parts entering (or leaving) the equipotential space (such as water pipes, etc.) must be encased in suitable insulating material and excluded from the equipotential network, since such parts are likely to be bonded to protective (earthed) conductors elsewhere in the installation.



# 4 Protection of goods in case of insulation fault

The standards consider the damage (mainly fire) of goods due to insulation faults to be high. Therefore, for location with high risk of fire, 300 mA Residual Current Devices must be used. For the other locations, some standards relies on technique called « Ground Fault Protection » (GFP).

## 4.1 Measures of protection against fire risk with RCDs

RCDs are very effective devices to provide protection against fire risk due to insulation fault because they can detect leakage current (ex : 300 mA) which are too low for the other protections, but sufficient to cause a fire

RCDs are very effective devices to provide protection against fire risk due to insulation fault. This type of fault current is actually too low to be detected by the other protection (overcurrent, reverse time).

For TT, IT TN-S systems in which leakage current can appear, the use of 300 mA sensitivity RCDs provides a good protection against fire risk due to this type of fault.

An investigation has shown that the cost of the fires in industrial and tertiary buildings can be very great.

The analysis of the phenomena shows that fire risk due to electricity is linked to overheating due to a bad coordination between the maximum rated current of the cable (or isolated conductor) and the overcurrent protection setting.

Overheating can also be due to the modification of the initial method of installation (addition of cables on the same support).

This overheating can be the origin of electrical arc in humid environment. These electrical arcs evolve when the fault current-loop impedance is greater than  $0.6 \Omega$  and exist only when an insulation fault occurs. Some tests have shown that a 300 mA fault current can induce a real risk of fire (see Fig. F26).

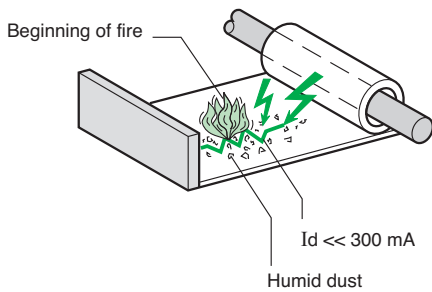

Some tests have shown that a very low leakage current (a few mA) can evolve and, from 300 mA, induce a fire in humid and dusty environment.

Fig. F26 : Origin of fires in buildings

## 4.2 Ground Fault Protection (GFP)

**Different type of ground fault protections** (see Fig. F27)

Three types of GFP are possible depending on the measuring device installed :

■ “Residual Sensing” RS

The “insulation fault” current is calculated using the vectorial sum of currents of current transformers secondaries. The current transformer on the neutral conductor is often outside the circuit-breaker.

■ “Source Ground Return” SGR

The « insulation fault current » is measured in the neutral – earth link of the LV transformer. The current transformer is outside the circuit-breaker.

■ “Zero Sequence” ZS

The « insulation fault » is directly measured at the secondary of the current transformer using the sum of currents in live conductors. This type of GFP is only used with low fault current values.

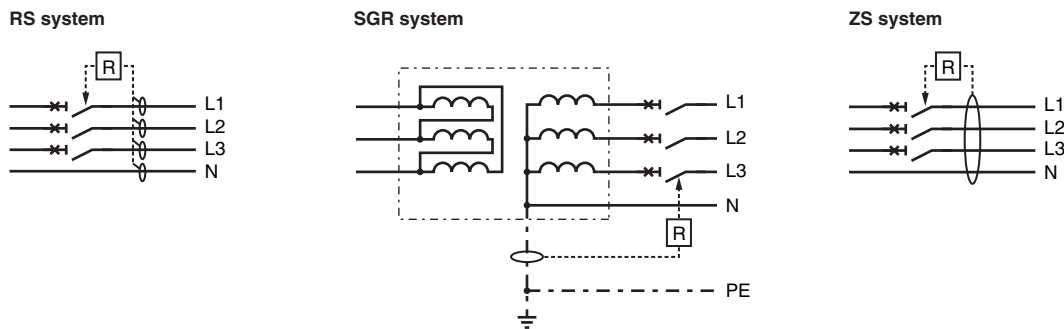

Fig. F27 : Different types of ground fault protections

## 4 Protection of goods in case of insulation fault

### Positioning GFP devices in the installation

Type / installation level	Main-distribution	Sub-distribution	Comments
Source Ground Return (SGR)	□		Used
Residual Sensing (RS) (SGR)	□	■	Often used
Zero Sequence (SGR)	□	■	Rarely used

□ Possible

■ Recommended or required

F18

## 5.1 Protective measures

### Protection against indirect contact

#### General case

Protection against indirect contact is assured by RCDs, the sensitivity  $I\Delta n$  of which complies with the condition  $I\Delta n \leq \frac{50 \text{ V}}{R_A}$  (1)

The choice of sensitivity of the residual current device is a function of the resistance  $R_A$  of the earth electrode for the installation, and is given in **Figure F28**.

$I\Delta n$	Maximum resistance of the earth electrode	
	(50 V)	(25 V)
3 A	16 $\Omega$	8 $\Omega$
1 A	50 $\Omega$	25 $\Omega$
500 mA	100 $\Omega$	50 $\Omega$
300 mA	166 $\Omega$	83 $\Omega$
30 mA	1666 $\Omega$	833 $\Omega$

**Fig. F28** : The upper limit of resistance for an installation earthing electrode which must not be exceeded, for given sensitivity levels of RCDs at  $U_L$  voltage limits of 50 V and 25 V

#### Case of distribution circuits (see Fig. F29)

IEC 60364-4-41 and a number of national standards recognize a maximum tripping time of 1 second in installation distribution circuits (as opposed to final circuits). This allows a degree of selective discrimination to be achieved:

- At level A: RCD time-delayed, e.g. "S" type
- At level B: RCD instantaneous

#### Case where the exposed conductive parts of an appliance, or group of appliances, are connected to a separate earth electrode (see Fig. F30)

Protection against indirect contact by a RCD at the circuit-breaker level protecting each group or separately-earthed individual appliance.

In each case, the sensitivity must be compatible with the resistance of the earth electrode concerned.

#### High-sensitivity RCDs (see Fig. F31)

According to IEC 60364-4-41, high sensitivity RCDs ( $\leq 30 \text{ mA}$ ) must be used for protection of socket outlets with rated current  $\leq 20 \text{ A}$  in all locations. The use of such RCDs is also recommended in the following cases:

- Socket-outlet circuits in wet locations at all current ratings
  - Socket-outlet circuits in temporary installations
  - Circuits supplying laundry rooms and swimming pools
  - Supply circuits to work-sites, caravans, pleasure boats, and travelling fairs
- See 2.2 and chapter P, section 3

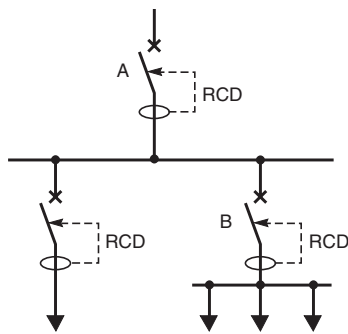

**Fig. F29** : Distribution circuits

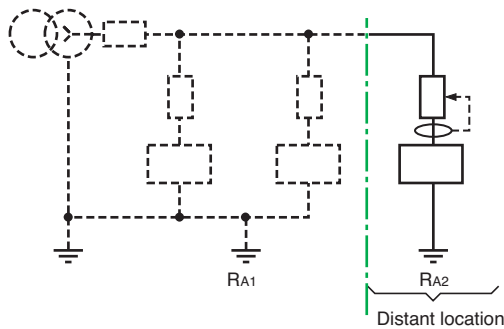

**Fig. F30** : Separate earth electrode

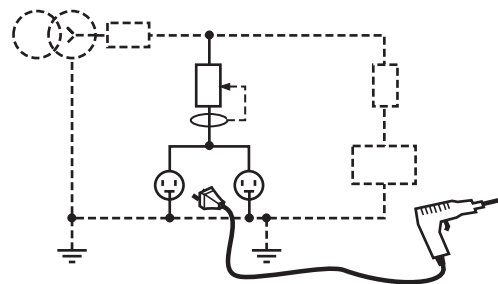

**Fig. F31** : Circuit supplying socket-outlets

(1) 25 V for work-site installations, agricultural establishments, etc.

### In high fire risk locations (see Fig. F32)

RCD protection at the circuit-breaker controlling all supplies to the area at risk is necessary in some locations, and mandatory in many countries.

The sensitivity of the RCD must be  $\leq 500$  mA, but a 300 mA sensitivity is recommended.

### Protection when exposed conductive parts are not connected to earth (see Fig. F33)

(In the case of an existing installation where the location is dry and provision of an earthing connection is not possible, or in the event that a protective earth wire becomes broken).

RCDs of high sensitivity ( $\leq 30$  mA) will afford both protection against indirect-contact hazards, and the additional protection against the dangers of direct-contact.

F20

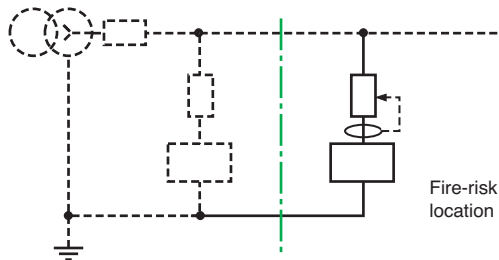

Fig. F32 : Fire-risk location

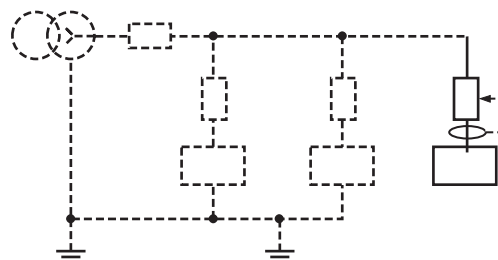

Fig. F33 : Unearthed exposed conductive parts (A)

## 5.2 Coordination of residual current protective devices

Discriminative-tripping coordination is achieved either by time-delay or by subdivision of circuits, which are then protected individually or by groups, or by a combination of both methods.

Such discrimination avoids the tripping of any RCD, other than that immediately upstream of a fault position:

■ With equipment currently available, discrimination is possible at three or four different levels of distribution :

- At the main general distribution board
- At local general distribution boards
- At sub-distribution boards
- At socket outlets for individual appliance protection

■ In general, at distribution boards (and sub-distribution boards, if existing) and on individual-appliance protection, devices for automatic disconnection in the event of an indirect-contact hazard occurring are installed together with additional protection against direct-contact hazards.

### Discrimination between RCDs

The general specification for achieving total discrimination between two RCDs is as follows:

- The ratio between the rated residual operating currents must be  $> 2$
- Time delaying the upstream RCD

Discrimination is achieved by exploiting the several levels of standardized sensitivity: 30 mA, 100 mA, 300 mA and 1 A and the corresponding tripping times, as shown opposite page in **Figure F34**.

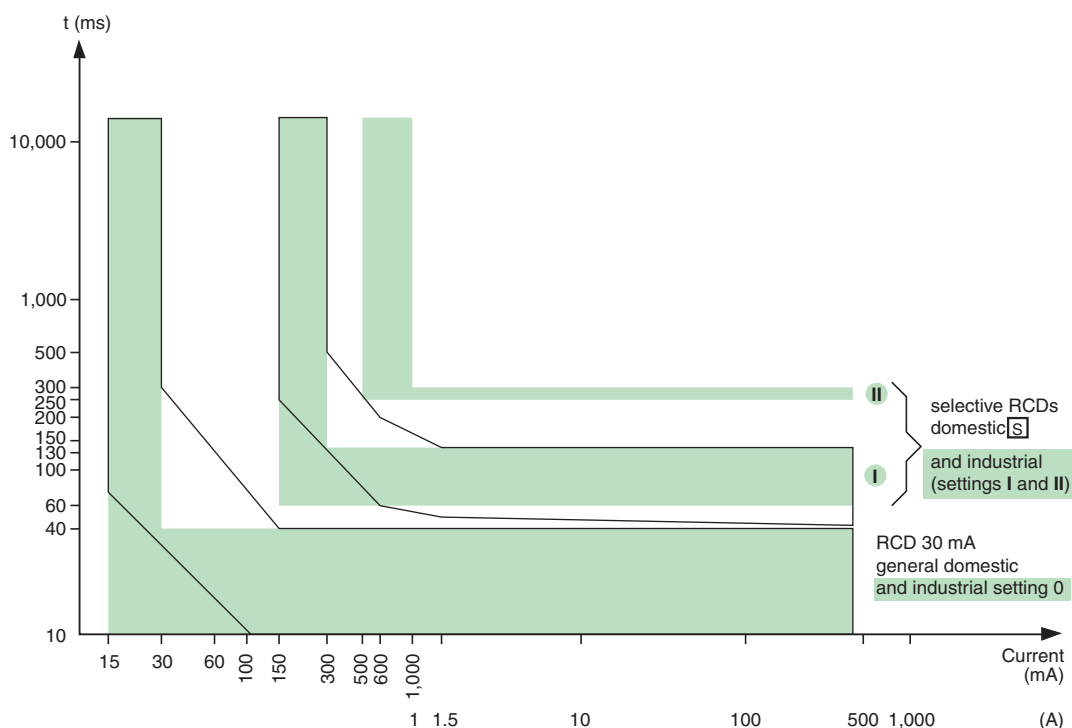

F21

Fig. F34 : Total discrimination at 2 levels

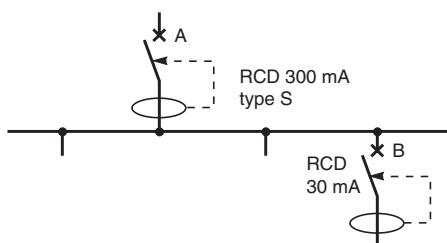

Fig. F35 : Total discrimination at 2 levels

### Discrimination at 2 levels (see Fig. F35)

#### Protection

- Level A: RCD time-delayed setting I (for industrial device) or type S (for domestic device) for protection against indirect contacts
- Level B: RCD instantaneous, with high sensitivity on circuits supplying socket-outlets or appliances at high risk (washing machines, etc.) See also Chapter P Clause 3

#### Schneider Electric solutions

- Level A: Compact or Multi 9 circuit-breaker with adaptable RCD module (Vigi NSX160 or Vigi NC100), setting I or S type
- Level B: Circuit-breaker with integrated RCD module (DPN Vigi) or adaptable RCD module (e.g. Vigi C60 or Vigi NC100) or Vigicompact

**Note:** The setting of upstream RCCB must comply with selectivity rules and take into account all the downstream earth leakage currents.

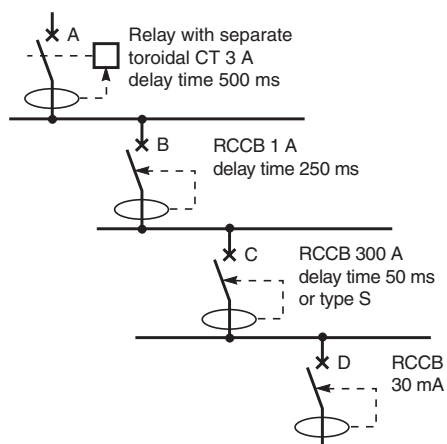

Fig. F36 : Total discrimination at 3 or 4 levels

### Discrimination at 3 or 4 levels (see Fig. F36)

#### Protection

- Level A: RCD time-delayed (setting III)
- Level B: RCD time-delayed (setting II)
- Level C: RCD time-delayed (setting I) or type S
- Level D: RCD instantaneous

#### Schneider Electric solutions

- Level A: Circuit-breaker associated with RCD and separate toroidal transformer (Vigirex RH328AP)
- Level B: Vigicompact or Vigirex
- Level C: Vigirex, Vigicompact or Vigi NC100 or Vigi C60
- Level D:
  - Vigicompact or
  - Vigirex or
  - Multi 9 with integrated or adaptable RCD module : Vigi C60 or DPN Vigi

**Note:** The setting of upstream RCCB must comply with selectivity rules and take into account all the downstream earth leakage currents

## Discriminative protection at three levels (see Fig. F37)

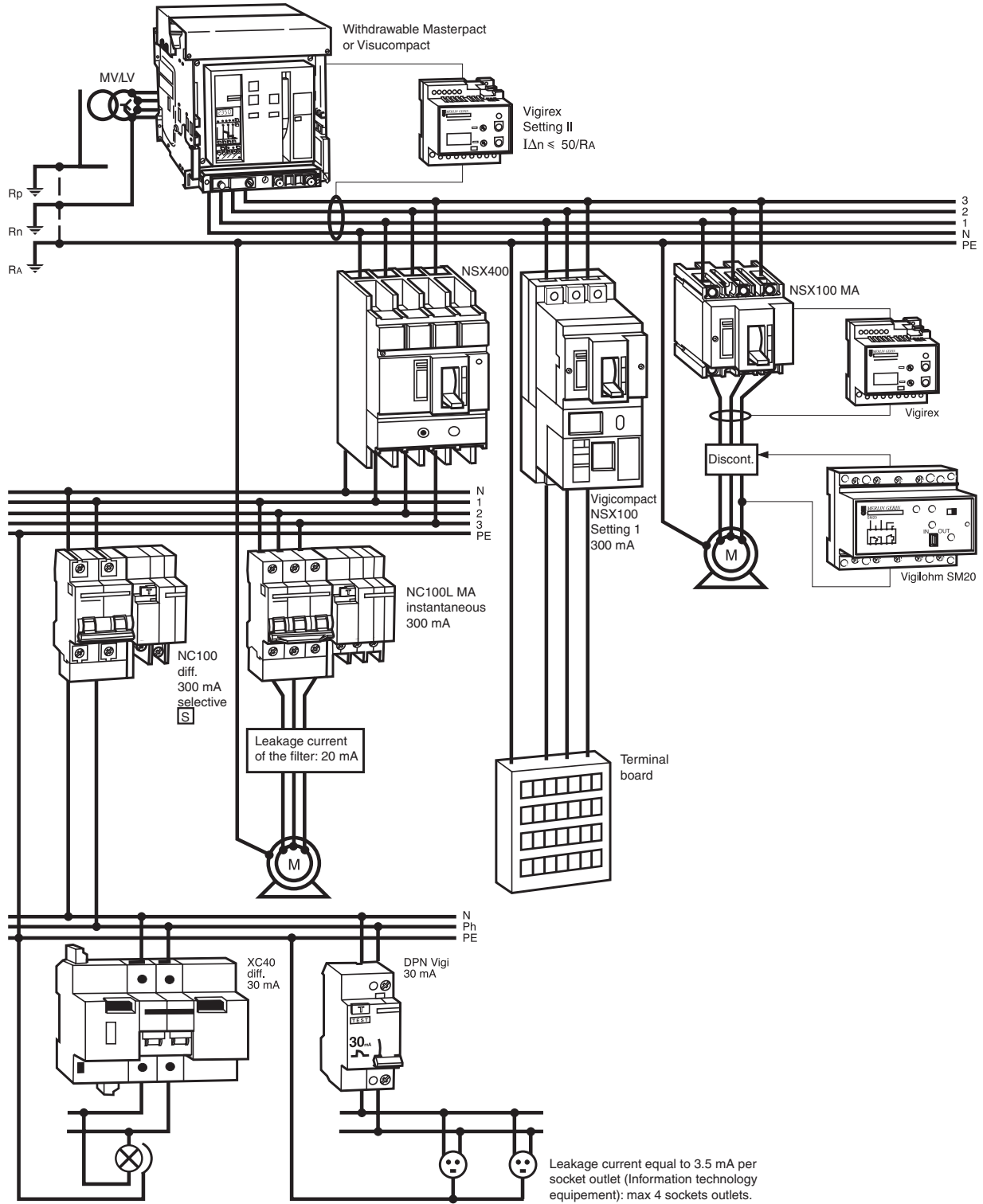

Fig. F37 : Typical 3-level installation, showing the protection of distribution circuits in a TT-earthed system. One motor is provided with specific protection

### 6.1 Preliminary conditions

At the design stage, the maximum permitted lengths of cable downstream of a protective circuit-breaker (or set of fuses) must be calculated, while during the installation work certain rules must be fully respected.

Certain conditions must be observed, as listed below and illustrated in **Figure F38**.

1. PE conductor must be regularly connected to earth as much as possible.
2. The PE conductor must not pass through ferro-magnetic conduit, ducts, etc. or be mounted on steel work, since inductive and/or proximity effects can increase the effective impedance of the conductor.
3. In the case of a PEN conductor (a neutral conductor which is also used as a protective conductor), connection must be made directly to the earth terminal of an appliance (see 3 in Figure F38) before being looped to the neutral terminal of the same appliance.
4. Where the conductor  $\leq 6 \text{ mm}^2$  for copper or  $10 \text{ mm}^2$  for aluminium, or where a cable is movable, the neutral and protective conductors should be separated (i.e. a TN-S system should be adopted within the installation).
5. Earth faults may be cleared by overcurrent-protection devices, i.e. by fuses and circuit-breakers.

The foregoing list indicates the conditions to be respected in the implementation of a TN scheme for the protection against indirect contacts.

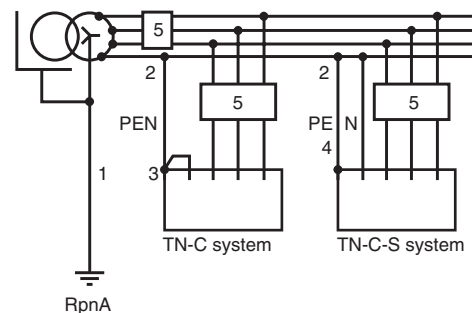

#### Notes:

- The TN scheme requires that the LV neutral of the MV/LV transformer, the exposed conductive parts of the substation and of the installation, and the extraneous conductive parts in the substation and installation, all be earthed to a common earthing system.
- For a substation in which the metering is at low-voltage, a means of isolation is required at the origin of the LV installation, and the isolation must be clearly visible.
- A PEN conductor must never be interrupted under any circumstances. Control and protective switchgear for the several TN arrangements will be:
  - 3-pole when the circuit includes a PEN conductor,
  - Preferably 4-pole (3 phases + neutral) when the circuit includes a neutral with a separate PE conductor.

**Fig. F38** : Implementation of the TN system of earthing

### 6.2 Protection against indirect contact

#### Methods of determining levels of short-circuit current

In TN-earthed systems, a short-circuit to earth will, in principle, always provide sufficient current to operate an overcurrent device.

The source and supply mains impedances are much lower than those of the installation circuits, so that any restriction in the magnitude of earth-fault currents will be mainly caused by the installation conductors (long flexible leads to appliances greatly increase the "fault-loop" impedance, with a corresponding reduction of short-circuit current).

The most recent IEC recommendations for indirect-contact protection on TN earthing systems only relates maximum allowable tripping times to the nominal system voltage (see Figure F12 in Sub-clause 3.3).

Three methods of calculation are commonly used:

- The method of impedances, based on the trigonometric addition of the system resistances and inductive reactances
- The method of composition
- The conventional method, based on an assumed voltage drop and the use of prepared tables

*For calculations, modern practice is to use software agreed by National Authorities, and based on the method of impedances, such as Ecodial 3. National Authorities generally also publish Guides, which include typical values, conductor lengths, etc.*

The reasoning behind these recommendations is that, for TN systems, the current which must flow in order to raise the potential of an exposed conductive part to 50 V or more is so high that one of two possibilities will occur:

- Either the fault path will blow itself clear, practically instantaneously, or
- The conductor will weld itself into a solid fault and provide adequate current to operate overcurrent devices

To ensure correct operation of overcurrent devices in the latter case, a reasonably accurate assessment of short-circuit earth-fault current levels must be determined at the design stage of a project.

A rigorous analysis requires the use of phase-sequence-component techniques applied to every circuit in turn. The principle is straightforward, but the amount of computation is not considered justifiable, especially since the zero-phase-sequence impedances are extremely difficult to determine with any reasonable degree of accuracy in an average LV installation.

Other simpler methods of adequate accuracy are preferred. Three practical methods are:

- The “**method of impedances**”, based on the summation of all the impedances (positive-phase-sequence only) around the fault loop, for each circuit
- The “**method of composition**”, which is an estimation of short-circuit current at the remote end of a loop, when the short-circuit current level at the near end of the loop is known
- The “**conventional method**” of calculating the minimum levels of earth-fault currents, together with the use of tables of values for obtaining rapid results

These methods are only reliable for the case in which the cables that make up the earth-fault-current loop are in close proximity (to each other) and not separated by ferro-magnetic materials.

### Method of impedances

This method summates the positive-sequence impedances of each item (cable, PE conductor, transformer, etc.) included in the earth-fault loop circuit from which the short-circuit earth-fault current is calculated, using the formula:

$$I = \frac{U_0}{\sqrt{(\sum R)^2 + (\sum X)^2}}$$

where

$(\sum R)^2$  = (the sum of all resistances in the loop)<sup>2</sup> at the design stage of a project.

and  $(\sum X)^2$  = (the sum of all inductive reactances in the loop)<sup>2</sup>

and  $U_0$  = nominal system phase-to-neutral voltage.

The application of the method is not always easy, because it supposes a knowledge of all parameter values and characteristics of the elements in the loop. In many cases, a national guide can supply typical values for estimation purposes.

### Method of composition

This method permits the determination of the short-circuit current at the end of a loop from the known value of short-circuit at the sending end, by means of the approximate formula:

$$I_{sc} = I \frac{U_0}{U + Z_s I_{sc}}$$

where

$I_{sc}$  = upstream short-circuit current

$I$  = end-of-loop short-circuit current

$U_0$  = nominal system phase voltage

$Z_s$  = impedance of loop

**Note:** in this method the individual impedances are added arithmetically<sup>(1)</sup> as opposed to the previous “method of impedances” procedure.

### Conventional method

This method is generally considered to be sufficiently accurate to fix the upper limit of cable lengths.

#### Principle

The principle bases the short-circuit current calculation on the assumption that the voltage at the origin of the circuit concerned (i.e. at the point at which the circuit protective device is located) remains at 80% or more of the nominal phase to neutral voltage. The 80% value is used, together with the circuit loop impedance, to compute the short-circuit current.

(1) This results in a calculated current value which is less than that it would actually flow. If the overcurrent settings are based on this calculated value, then operation of the relay, or fuse, is assured.



## 6 Implementation of the TN system

The maximum length of any circuit of a TN-earthed installation is:  $\frac{0.8 U_0 S_{ph}}{\rho(1+m)I_a}$

This coefficient takes account of all voltage drops upstream of the point considered. In LV cables, when all conductors of a 3-phase 4-wire circuit are in close proximity (which is the normal case), the inductive reactance internal to and between conductors is negligibly small compared to the cable resistance.

This approximation is considered to be valid for cable sizes up to 120 mm<sup>2</sup>.

Above that size, the resistance value R is increased as follows:

Core size (mm <sup>2</sup> )	Value of resistance
S = 150 mm <sup>2</sup>	R+15%
S = 185 mm <sup>2</sup>	R+20%
S = 240 mm <sup>2</sup>	R+25%

The maximum length of a circuit in a TN-earthed installation is given by the formula:

$$L_{max} = \frac{0.8 U_0 S_{ph}}{\rho(1+m)I_a}$$

where:

L<sub>max</sub> = maximum length in metres

U<sub>0</sub> = phase volts = 230 V for a 230/400 V system

ρ = resistivity at normal working temperature in ohm-mm<sup>2</sup>/metre  
(= 22.5 · 10<sup>-3</sup> for copper; = 36 · 10<sup>-3</sup> for aluminium)

I<sub>a</sub> = trip current setting for the instantaneous operation of a circuit-breaker, or

I<sub>a</sub> = the current which assures operation of the protective fuse concerned, in the specified time.

$$m = \frac{S_{ph}}{S_{PE}}$$

S<sub>ph</sub> = cross-sectional area of the phase conductors of the circuit concerned in mm<sup>2</sup>

S<sub>PE</sub> = cross-sectional area of the protective conductor concerned in mm<sup>2</sup>.

(see Fig. F39)

F25

The following tables give the length of circuit which must not be exceeded, in order that persons be protected against indirect contact hazards by protective devices

### Tables

The following tables, applicable to TN systems, have been established according to the "conventional method" described above.

The tables give maximum circuit lengths, beyond which the ohmic resistance of the conductors will limit the magnitude of the short-circuit current to a level below that required to trip the circuit-breaker (or to blow the fuse) protecting the circuit, with sufficient rapidity to ensure safety against indirect contact.

### Correction factor m

Figure F40 indicates the correction factor to apply to the values given in Figures F41 to F44 next pages, according to the ratio S<sub>ph</sub>/S<sub>PE</sub>, the type of circuit, and the conductor materials.

The tables take into account:

- The type of protection: circuit-breakers or fuses
- Operating-current settings
- Cross-sectional area of phase conductors and protective conductors
- Type of system earthing (see Fig. F45 page F27)
- Type of circuit-breaker (i.e. B, C or D)<sup>(1)</sup>

The tables may be used for 230/400 V systems.

Equivalent tables for protection by Compact and Multi 9 circuit-breakers (Merlin Gerin) are included in the relevant catalogues.

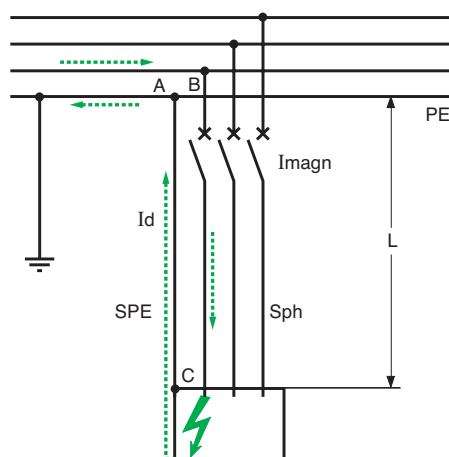

Fig. F39 : Calculation of L<sub>max</sub> for a TN-earthed system, using the conventional method

Fig. F40 : Correction factor to apply to the lengths given in tables F41 to F44 for TN systems

Circuit	Conductor material	m = S <sub>ph</sub> /S <sub>PE</sub> (or PEN)			
		m = 1	m = 2	m = 3	m = 4
3P + N or P + N	Copper	1	0.67	0.50	0.40
	Aluminium	0.62	0.42	0.31	0.25

(1) For the definition of type B, C, D circuit-breakers, refer to chapter H, clause 4.2

F - Protection against electric shock

Circuits protected by general purpose circuit-breakers (Fig. F41)

Nominal cross-sectional area of conductors	Instantaneous or short-time-delayed tripping current $I_m$ (amperes)																																		
	50	63	80	100	125	160	200	250	320	400	500	560	630	700	800	875	1000	1120	1250	1600	2000	2500	3200	4000	5000	6300	8000	10000	12500						
1.5	100	79	63	50	40	31	25	20	16	13	10	9	8	7	6	6	5	4	4																
2.5	167	133	104	83	67	52	42	33	26	21	17	15	13	12	10	10	8	7	7	5	4														
4	267	212	167	133	107	83	67	53	42	33	27	24	21	19	17	15	13	12	11	8	7	5	4												
6	400	317	250	200	160	125	100	80	63	50	40	36	32	29	25	23	20	18	16	13	10	8	6	5	4										
10			417	333	267	208	167	133	104	83	67	60	53	48	42	38	33	30	27	21	17	13	10	8	7	5	4								
16				427	333	267	213	167	133	107	95	85	76	67	61	53	48	43	33	27	21	17	13	11	8	7	5	4							
25					417	333	260	208	167	149	132	119	104	95	83	74	67	52	42	33	26	21	17	13	10	8	7								
35						467	365	292	233	208	185	167	146	133	117	104	93	73	58	47	36	29	23	19	15	12	9								
50							495	396	317	283	251	226	198	181	158	141	127	99	79	63	49	40	32	25	20	16	13								
70								417	370	333	292	267	233	208	187	146	117	93	73	58	47	37	29	23	19	15	12	9							
95									452	396	362	317	283	263	198	158	127	99	79	63	50	40	32	25	20	16	13	10							
120										457	400	357	320	250	200	160	125	100	80	63	50	40	32	25	20	16	13	10	8						
150											435	388	348	272	217	174	136	109	87	69	54	43	35	28	22	17	14	11	9						
185												459	411	321	257	206	161	128	103	82	64	51	41	32	25	20	16	13	10	8					
240																400	320	256	200	160	128	102	80	64	51	41	32	25	20	16	13	10	8		

Fig. F41 : Maximum circuit lengths (in metres) for different sizes of copper conductor and instantaneous-tripping-current settings for general-purpose circuit-breakers in 230/400 V TN system with  $m = 1$

Circuits protected by Compact or Multi 9 circuit-breakers for industrial or domestic use (Fig. F42 to Fig. F44)

Sph	Rated current (A)															
	1	2	3	4	6	10	16	20	25	32	40	50	63	80	100	125
1.5	1200	600	400	300	200	120	75	60	48	37	30	24	19	15	12	10
2.5		1000	666	500	333	200	125	100	80	62	50	40	32	25	20	16
4			1066	800	533	320	200	160	128	100	80	64	51	40	32	26
6				1200	800	480	300	240	192	150	120	96	76	60	48	38
10					800	500	400	320	250	200	160	127	100	80	64	
16						800	640	512	400	320	256	203	160	128	102	
25							800	625	500	400	317	250	200	160		
35								875	700	560	444	350	280	224		
50										760	603	475	380	304		

Fig. F42 : Maximum circuit lengths (in meters) for different sizes of copper conductor and rated currents for type B<sup>(1)</sup> circuit-breakers in a 230/400 V single-phase or three-phase TN system with  $m = 1$

Sph	Rated current (A)																
	1	2	3	4	6	10	16	20	25	32	40	50	63	80	100	125	
1.5	600	300	200	150	100	60	37	30	24	18	15	12	9	7	6	5	
2.5		500	333	250	167	100	62	50	40	31	25	20	16	12	10	8	
4			533	400	267	160	100	80	64	50	40	32	25	20	16	13	
6				600	400	240	150	120	96	75	60	48	38	30	24	19	
10					667	400	250	200	160	125	100	80	63	50	40	32	
16						640	400	320	256	200	160	128	101	80	64	51	
25							625	500	400	312	250	200	159	125	100	80	
35								875	700	560	437	350	280	222	175	140	112
50										760	594	475	380	301	237	190	152

Fig. F43 : Maximum circuit lengths (in metres) for different sizes of copper conductor and rated currents for type C<sup>(1)</sup> circuit-breakers in a 230/400 V single-phase or three-phase TN system with  $m = 1$

(1) For the definition of type B and C circuit-breakers refer to chapter H clause 4.2.

## 6 Implementation of the TN system

Sph mm <sup>2</sup>	Rated current (A)															
	1	2	3	4	6	10	16	20	25	32	40	50	63	80	100	125
1.5	429	214	143	107	71	43	27	21	17	13	11	9	7	5	4	3
2.5	714	357	238	179	119	71	45	36	29	22	18	14	11	9	7	6
4		571	381	286	190	114	71	80	46	36	29	23	18	14	11	9
6		857	571	429	286	171	107	120	69	54	43	34	27	21	17	14
10			952	714	476	286	179	200	114	89	71	57	45	36	29	23
16				762	457	286	320	183	143	114	91	73	57	46	37	
25					714	446	500	286	223	179	143	113	89	71	57	
35						625	700	400	313	250	200	159	125	80	100	
50							848	543	424	339	271	215	170	136	109	

Fig. F44 : Maximum circuit lengths (in metres) for different sizes of copper conductor and rated currents for type D<sup>(1)</sup> circuit-breakers in a 230/400 V single-phase or three-phase TN system with  $m = 1$

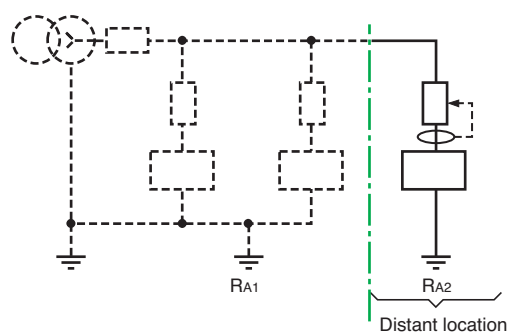

Fig. F45 : Separate earth electrode

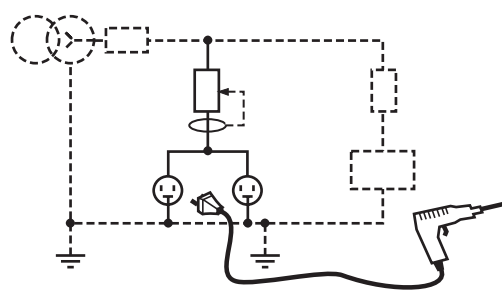

Fig. F46 : Circuit supplying socket-outlets

### Example

A 3-phase 4-wire (230/400 V) installation is TN-C earthed. A circuit is protected by a type B circuit-breaker rated at 63 A, and consists of an aluminium cored cable with 50 mm<sup>2</sup> phase conductors and a neutral conductor (PEN) of 25 mm<sup>2</sup>.

What is the maximum length of circuit, below which protection of persons against indirect-contact hazards is assured by the instantaneous magnetic tripping relay of the circuit-breaker?

Figure F42 gives, for 50 mm<sup>2</sup> and a 63 A type B circuit-breaker, 603 metres, to which must be applied a factor of 0.42 (Figure F40 for  $m = \frac{S_{ph}}{S_{PE}} = 2$ ).

The maximum length of circuit is therefore:

$$603 \times 0.42 = 253 \text{ metres.}$$

### Particular case where one or more exposed conductive part(s) is (are) earthed to a separate earth electrode

Protection must be provided against indirect contact by a RCD at the origin of any circuit supplying an appliance or group of appliances, the exposed conductive parts of which are connected to an independent earth electrode.

The sensitivity of the RCD must be adapted to the earth electrode resistance ( $R_{A2}$  in Figure F45). See specifications applicable to TT system.

### 6.3 High-sensitivity RCDs (see Fig. F31)

According to IEC 60364-4-41, high sensitivity RCDs ( $\leq 30$  mA) must be used for protection of socket outlets with rated current  $\leq 20$  A in all locations. The use of such RCDs is also recommended in the following cases:

- Socket-outlet circuits in wet locations at all current ratings
  - Socket-outlet circuits in temporary installations
  - Circuits supplying laundry rooms and swimming pools
  - Supply circuits to work-sites, caravans, pleasure boats, and travelling fairs
- See 2.2 and chapter P, al section 3.

F27

(1) For the definition of type D circuit-breaker refer to chapter H Sub-clause 4.2.

## 6.4 Protection in high fire-risk location

According to IEC 60364-422-3.10, circuits in high fire-risk locations must be protected by RCDs of sensitivity  $\leq 500$  mA. This excludes the TN-C arrangement and TN-S must be adopted.

A preferred sensitivity of 300 mA is mandatory in some countries (see Fig. F47).

## 6.5 When the fault current-loop impedance is particularly high

When the earth-fault current is limited due to an inevitably high fault-loop impedance, so that the overcurrent protection cannot be relied upon to trip the circuit within the prescribed time, the following possibilities should be considered:

### Suggestion 1 (see Fig. F48)

■ Install a circuit-breaker which has a lower instantaneous magnetic tripping level, for example:

$$2I_n \leq I_{rm} \leq 4I_n$$

This affords protection for persons on circuits which are abnormally long. It must be checked, however, that high transient currents such as the starting currents of motors will not cause nuisance trip-outs.

- Schneider Electric solutions
- Type G Compact ( $2I_m \leq I_{rm} \leq 4I_m$ )
- Type B Multi 9 circuit-breaker

### Suggestion 2 (see Fig. F49)

■ Install a RCD on the circuit. The device does not need to be highly-sensitive (HS) (several amps to a few tens of amps). Where socket-outlets are involved, the particular circuits must, in any case, be protected by HS ( $\leq 30$  mA) RCDs; generally one RCD for a number of socket outlets on a common circuit.

- Schneider Electric solutions
- RCD Multi 9 NG125 :  $I_{\Delta n} = 1$  or 3 A
- Vigicompact REH or REM:  $I_{\Delta n} = 3$  to 30 A
- Type B Multi 9 circuit-breaker

### Suggestion 3

Increase the size of the PE or PEN conductors and/or the phase conductors, to reduce the loop impedance.

### Suggestion 4

Add supplementary equipotential conductors. This will have a similar effect to that of suggestion 3, i.e. a reduction in the earth-fault-loop resistance, while at the same time improving the existing touch-voltage protection measures. The effectiveness of this improvement may be checked by a resistance test between each exposed conductive part and the local main protective conductor.

For TN-C installations, bonding as shown in Figure F50 is not allowed, and suggestion 3 should be adopted.

F28

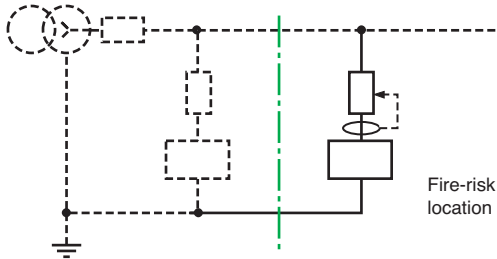

Fig. F47 : Fire-risk location

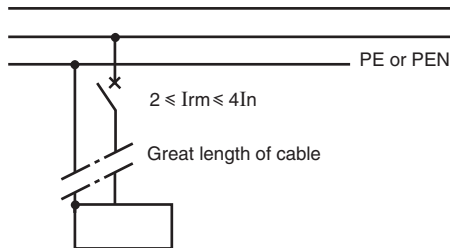

Fig. F48 : Circuit-breaker with low-set instantaneous magnetic tripping

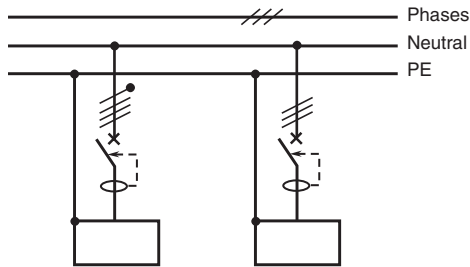

Fig. F49 : RCD protection on TN systems with high earth-fault-loop impedance

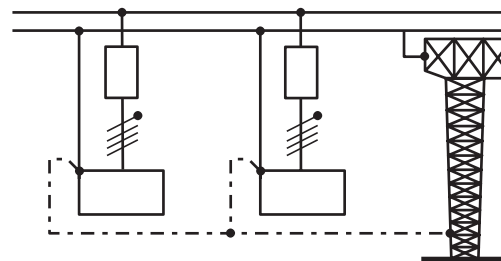

Fig. F50 : Improved equipotential bonding

# 7 Implementation of the IT system

The basic feature of the IT earthing system is that, in the event of a short-circuit to earth fault, the system can continue to operate without interruption. Such a fault is referred to as a "first fault".

In this system, all exposed conductive parts of an installation are connected via PE conductors to an earth electrode at the installation, while the neutral point of the supply transformer is:

- Either isolated from earth
- Or connected to earth through a high resistance (commonly 1,000 ohms or more)

This means that the current through an earth fault will be measured in milli-amps, which will not cause serious damage at the fault position, or give rise to dangerous touch voltages, or present a fire hazard. The system may therefore be allowed to operate normally until it is convenient to isolate the faulty section for repair work. This enhances continuity of service.

In practice, the system earthing requires certain specific measures for its satisfactory exploitation:

- Permanent monitoring of the insulation with respect to earth, which must signal (audibly or visually) the occurrence of the first fault
- A device for limiting the voltage which the neutral point of the supply transformer can reach with respect to earth
- A "first-fault" location routine by an efficient maintenance staff. Fault location is greatly facilitated by automatic devices which are currently available
- Automatic high-speed tripping of appropriate circuit-breakers must take place in the event of a "second fault" occurring before the first fault is repaired. The second fault (by definition) is an earth fault affecting a different live conductor than that of the first fault (can be a phase or neutral conductor)<sup>(1)</sup>.

The second fault results in a short-circuit through the earth and/or through PE bonding conductors.

F29

## 7.1 Preliminary conditions (see Fig. F51 and Fig. F52)

Minimum functions required	Components and devices	Examples
Protection against overvoltages at power frequency	(1) Voltage limiter	Cardew C
Neutral earthing resistor (for impedance earthing variation)	(2) Resistor	Impedance Zx
Overall earth-fault monitor with alarm for first fault condition	(3) Permanent insulation monitor PIM with alarm feature	Vigilohm TR22A or XM 200
Automatic fault clearance on second fault and protection of the neutral conductor against overcurrent	(4) Four-pole circuit-breakers (if the neutral is distributed) all 4 poles trip	Compact circuit-breaker or RCD-MS
Location of first fault	(5) With device for fault-location on live system, or by successive opening of circuits	Vigilohm system

Fig. F51 : Essential functions in IT schemes and examples with Merlin Gerin products

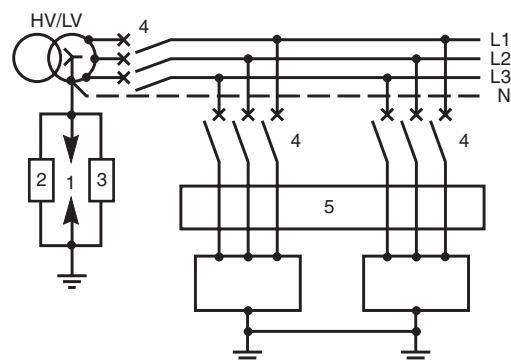

Fig. F52 : Positions of essential functions in 3-phase 3-wire IT-earthed system

(1) On systems where the neutral is distributed, as shown in Figure F56.

## 7.2 Protection against indirect contact

Modern monitoring systems greatly facilitate first-fault location and repair

### First-fault condition

The earth-fault current which flows under a first-fault condition is measured in milli-amps.

The fault voltage with respect to earth is the product of this current and the resistance of the installation earth electrode and PE conductor (from the faulted component to the electrode). This value of voltage is clearly harmless and could amount to several volts only in the worst case (1,000 Ω earthing resistor will pass 230 mA<sup>(1)</sup> and a poor installation earth-electrode of 50 ohms, would give 11.5 V, for example).

An alarm is given by the permanent insulation monitoring device.

### Principle of earth-fault monitoring

A generator of very low frequency a.c. current, or of d.c. current, (to reduce the effects of cable capacitance to negligible levels) applies a voltage between the neutral point of the supply transformer and earth. This voltage causes a small current to flow according to the insulation resistance to earth of the whole installation, plus that of any connected appliance.

Low-frequency instruments can be used on a.c. systems which generate transient d.c. components under fault conditions. Certain versions can distinguish between resistive and capacitive components of the leakage current.

Modern equipment allow the measurement of leakage-current evolution, so that prevention of a first fault can be achieved.

### Examples of equipment

- Manual fault-location (see Fig. F53)

The generator may be fixed (example: XM100) or portable (example: GR10X) permitting the checking of dead circuits and the receiver, together with the magnetic clamp-type pick-up sensor, are portable.

Fault-location systems comply with IEC 61157-9 standard

F30

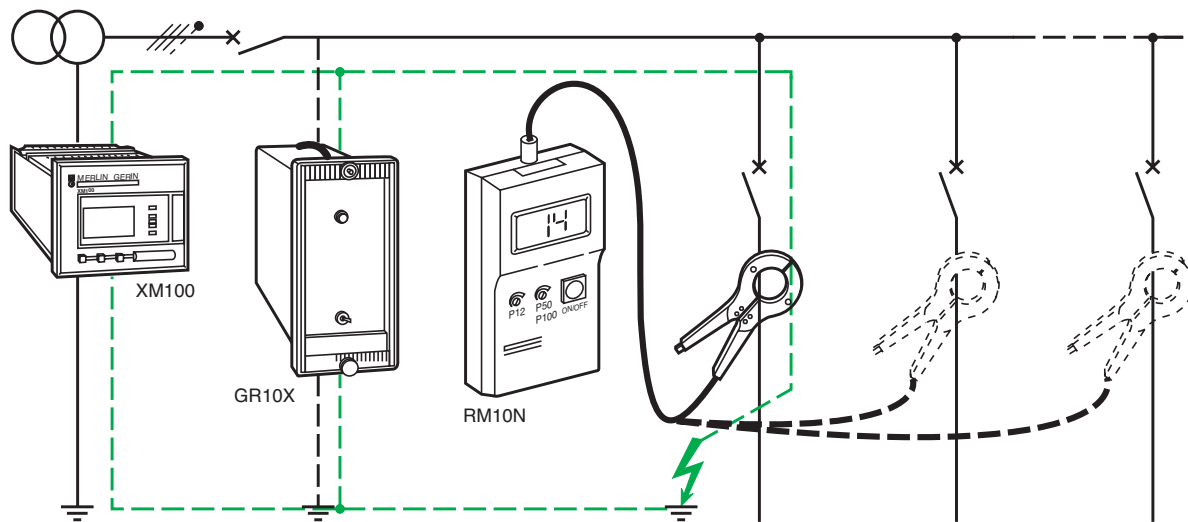

Fig. F53 : Non-automatic (manual) fault location

- Fixed automatic fault location (see Fig. F54 next page)

The monitoring relay XM100, together with the fixed detectors XD1 or XD12 (each connected to a toroidal CT embracing the conductors of the circuit concerned) provide a system of automatic fault location on a live installation.

Moreover, the level of insulation is indicated for each monitored circuit, and two levels are checked: the first level warns of unusually low insulation resistance so that preventive measures may be taken, while the second level indicates a fault condition and gives an alarm.

(1) On a 230/400 V 3-phase system.

## 7 Implementation of the IT system

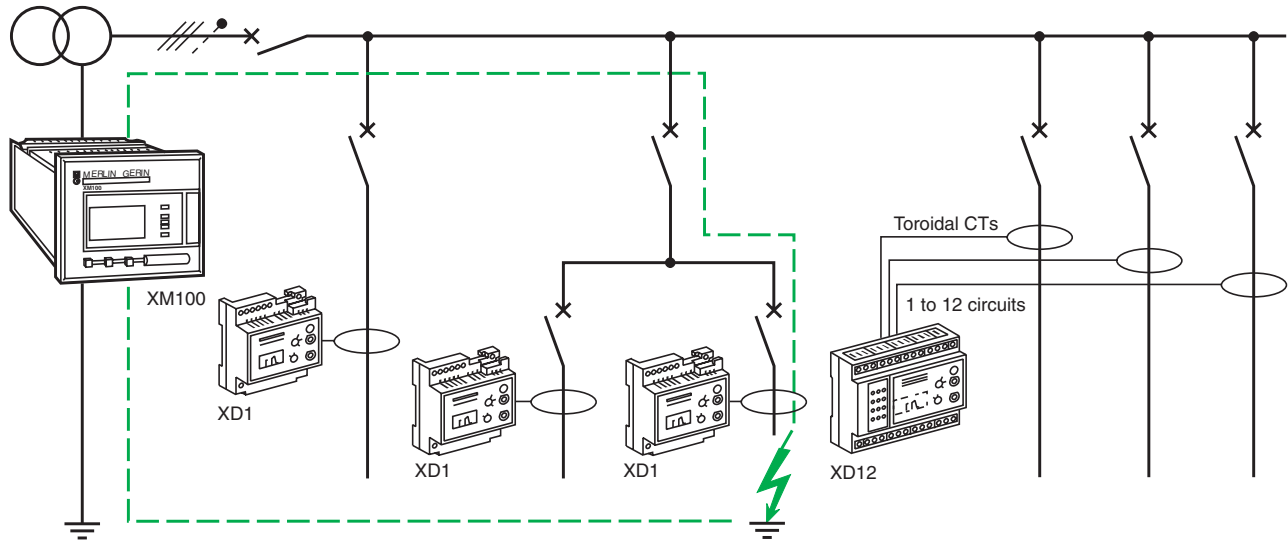

F31

Fig. F54 : Fixed automatic fault location

### ■ Automatic monitoring, logging, and fault location (see Fig. F55)

The VigiloHM System also allows access to a printer and/or a PC which provides a global review of the insulation level of an entire installation, and records the chronological evolution of the insulation level of each circuit.

The central monitor XM100, together with the localization detectors XD08 and XD16, associated with toroidal CTs from several circuits, as shown below in Figure F55, provide the means for this automatic exploitation.

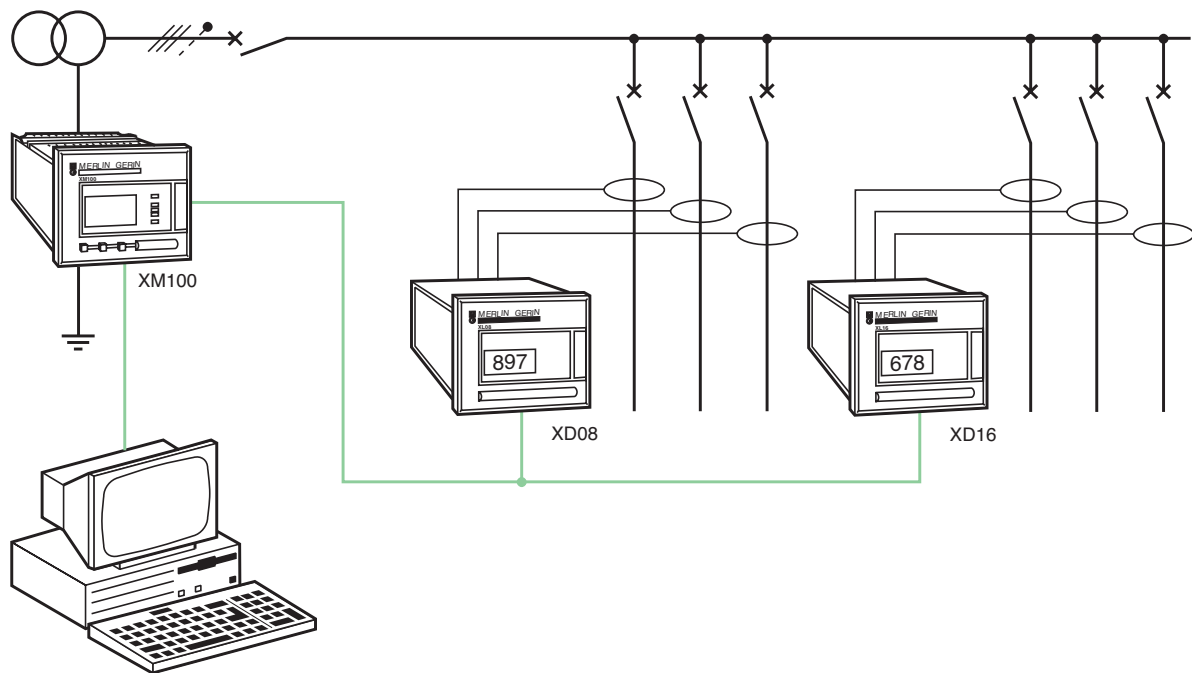

Fig. F55 : Automatic fault location and insulation-resistance data logging

**Implementation of permanent insulation-monitoring (PIM) devices**

■ Connection

The PIM device is normally connected between the neutral (or artificial neutral) point of the power-supply transformer and its earth electrode.

■ Supply

Power supply to the PIM device should be taken from a highly reliable source. In practice, this is generally directly from the installation being monitored, through overcurrent protective devices of suitable short-circuit current rating.

■ Level settings

Certain national standards recommend a first setting at 20% below the insulation level of the new installation. This value allows the detection of a reduction of the insulation quality, necessitating preventive maintenance measures in a situation of incipient failure.

The detection level for earth-fault alarm will be set at a much lower level.

By way of an example, the two levels might be:

- New installation insulation level: 100 kΩ
- Leakage current without danger: 500 mA (fire risk at > 500 mA)
- Indication levels set by the consumer:
  - Threshold for preventive maintenance:  $0.8 \times 100 = 80 \text{ k}\Omega$
  - Threshold for short-circuit alarm: 500 Ω

**Notes:**

- Following a long period of shutdown, during which the whole, or part of the installation remains de-energized, humidity can reduce the general level of insulation resistance. This situation, which is mainly due to leakage current over the damp surface of healthy insulation, does not constitute a fault condition, and will improve rapidly as the normal temperature rise of current-carrying conductors reduces the surface humidity.
- The PIM device (XM) can measure separately the resistive and the capacitive current components of the leakage current to earth, thereby deriving the true insulation resistance from the total permanent leakage current.

**The case of a second fault**

A second earth fault on an IT system (unless occurring on the same conductor as the first fault) constitutes a phase-phase or phase-to-neutral fault, and whether occurring on the same circuit as the first fault, or on a different circuit, overcurrent protective devices (fuses or circuit-breakers) would normally operate an automatic fault clearance.

The settings of overcurrent tripping relays and the ratings of fuses are the basic parameters that decide the maximum practical length of circuit that can be satisfactorily protected, as discussed in Sub-clause 6.2.

**Note:** In normal circumstances, the fault current path is through common PE conductors, bonding all exposed conductive parts of an installation, and so the fault loop impedance is sufficiently low to ensure an adequate level of fault current.

Where circuit lengths are unavoidably long, and especially if the appliances of a circuit are earthed separately (so that the fault current passes through two earth electrodes), reliable tripping on overcurrent may not be possible.

In this case, an RCD is recommended on each circuit of the installation.

Where an IT system is resistance earthed, however, care must be taken to ensure that the RCD is not too sensitive, or a first fault may cause an unwanted trip-out. Tripping of residual current devices which satisfy IEC standards may occur at values of  $0.5 I_{\Delta n}$  to  $I_{\Delta n}$ , where  $I_{\Delta n}$  is the nominal residual-current setting level.

**Methods of determining levels of short-circuit current**

A reasonably accurate assessment of short-circuit current levels must be carried out at the design stage of a project.

A rigorous analysis is not necessary, since current magnitudes only are important for the protective devices concerned (i.e. phase angles need not be determined) so that simplified conservatively approximate methods are normally used. Three practical methods are:

- The **method of impedances**, based on the vectorial summation of all the (positive-phase-sequence) impedances around a fault-current loop
- The **method of composition**, which is an approximate estimation of short-circuit current at the remote end of a loop, when the level of short-circuit current at the near end of the loop is known. Complex impedances are combined arithmetically in this method
- The **conventional method**, in which the minimum value of voltage at the origin of a faulty circuit is assumed to be 80% of the nominal circuit voltage, and tables are used based on this assumption, to give direct readings of circuit lengths.

*Three methods of calculation are commonly used:*

- *The method of impedances, based on the trigonometric addition of the system resistances and inductive reactances*
- *The method of composition*
- *The conventional method, based on an assumed voltage drop and the use of prepared tables*



# 7 Implementation of the IT system

The software Ecodial is based on the "method of impedance"

The maximum length of an IT earthed circuit is:

■ For a 3-phase 3-wire scheme

$$L_{\max} = \frac{0.8 U_0 \sqrt{3} S_{ph}}{2 \rho I_a (1+m)}$$

■ For a 3-phase 4-wire scheme

$$L_{\max} = \frac{0.8 U_0 S_1}{2 \rho I_a (1+m)}$$

These methods are reliable only for the cases in which wiring and cables which make up the fault-current loop are in close proximity (to each other) and are not separated by ferro-magnetic materials.

### Methods of impedances

This method as described in Sub-clause 6.2, is identical for both the IT and TN systems of earthing.

### Methods of composition

This method as described in Sub-clause 6.2, is identical for both the IT and TN systems of earthing.

### Conventional method (see Fig. F56)

The principle is the same for an IT system as that described in Sub-clause 6.2 for a TN system : the calculation of maximum circuit lengths which should not be exceeded downstream of a circuit-breaker or fuses, to ensure protection by overcurrent devices.

It is clearly impossible to check circuit lengths for every feasible combination of two concurrent faults.

All cases are covered, however, if the overcurrent trip setting is based on the assumption that a first fault occurs at the remote end of the circuit concerned, while the second fault occurs at the remote end of an identical circuit, as already mentioned in Sub-clause 3.4. This may result, in general, in one trip-out only occurring (on the circuit with the lower trip-setting level), thereby leaving the system in a first-fault situation, but with one faulty circuit switched out of service.

■ For the case of a 3-phase 3-wire installation the second fault can only cause a phase/phase short-circuit, so that the voltage to use in the formula for maximum circuit length is  $\sqrt{3} U_0$ .

The maximum circuit length is given by:

$$L_{\max} = \frac{0.8 U_0 \sqrt{3} S_{ph}}{2 \rho I_a (1+m)} \text{ metres}$$

■ For the case of a 3-phase 4-wire installation the lowest value of fault current will occur if one of the faults is on a neutral conductor. In this case,  $U_0$  is the value to use for computing the maximum cable length, and

$$L_{\max} = \frac{0.8 U_0 S_1}{2 \rho I_a (1+m)} \text{ metres}$$

i.e. 50% only of the length permitted for a TN scheme <sup>(1)</sup>

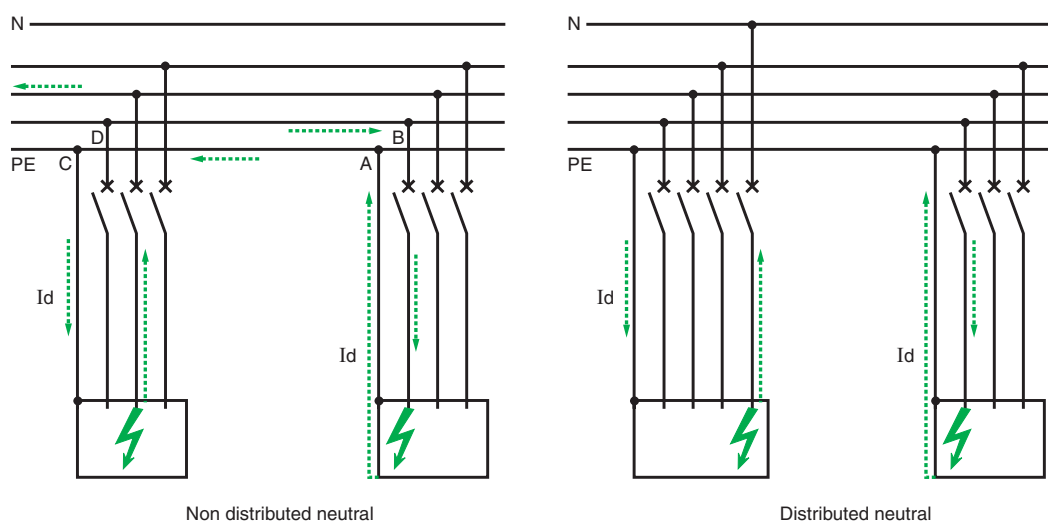

Fig. F56 : Calculation of  $L_{\max}$  for an IT-earthed system, showing fault-current path for a double-fault condition

(1) Reminder: There is no length limit for earth-fault protection on a TT scheme, since protection is provided by RCDs of high sensitivity.

F34

The following tables<sup>(1)</sup> give the length of circuit which must not be exceeded, in order that persons be protected against indirect contact hazards by protective devices

In the preceding formulae:

L<sub>max</sub> = longest circuit in metres

U<sub>o</sub> = phase-to-neutral voltage (230 V on a 230/400 V system)

ρ = resistivity at normal operating temperature (22.5 x 10<sup>-3</sup> ohms-mm<sup>2</sup>/m for copper, 36 x 10<sup>-3</sup> ohms-mm<sup>2</sup>/m for aluminium)

I<sub>a</sub> = overcurrent trip-setting level in amps, or I<sub>a</sub> = current in amps required to clear the fuse in the specified time

$$m = \frac{S_{ph}}{SPE}$$

SPE = cross-sectional area of PE conductor in mm<sup>2</sup>

S1 = S neutral if the circuit includes a neutral conductor

S1 = S<sub>ph</sub> if the circuit does not include a neutral conductor

### Tables

The following tables have been established according to the "conventional method" described above.

The tables give maximum circuit lengths, beyond which the ohmic resistance of the conductors will limit the magnitude of the short-circuit current to a level below that required to trip the circuit-breaker (or to blow the fuse) protecting the circuit, with sufficient rapidity to ensure safety against indirect contact. The tables take into account:

- The type of protection: circuit-breakers or fuses, operating-current settings
- Cross-sectional area of phase conductors and protective conductors
- Type of earthing scheme
- Correction factor: **Figure F57** indicates the correction factor to apply to the lengths given in tables F40 to F43, when considering an IT system

Circuit	Conductor material	m = S <sub>ph</sub> /SPE (or PEN)			
		m = 1	m = 2	m = 3	m = 4
3 phases	Copper	0.86	0.57	0.43	0.34
	Aluminium	0.54	0.36	0.27	0.21
3ph + N or 1ph + N	Copper	0.50	0.33	0.25	0.20
	Aluminium	0.31	0.21	0.16	0.12

Fig. F57 : Correction factor to apply to the lengths given in tables F41 to F44 for TN systems

### Example

A 3-phase 3-wire 230/400 V installation is IT-earthed.

One of its circuits is protected by a circuit-breaker rated at 63 A, and consists of an aluminium-cored cable with 50 mm<sup>2</sup> phase conductors. The 25 mm<sup>2</sup> PE conductor is also aluminium. What is the maximum length of circuit, below which protection of persons against indirect-contact hazards is assured by the instantaneous magnetic tripping relay of the circuit-breaker?

Figure F42 indicates 603 metres, to which must be applied a correction factor of 0.36 (m = 2 for aluminium cable).

The maximum length is therefore 217 metres.

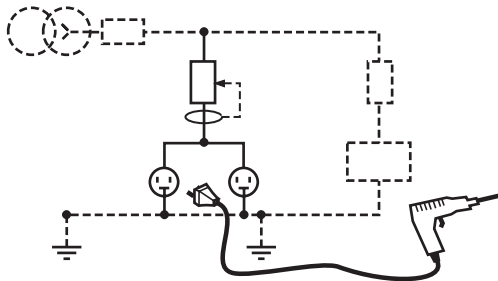

Fig. F62 : Circuit supplying socket-outlets

## 7.3 High-sensitivity RCDs

According to IEC 60364-4-41, high sensitivity RCDs (≤ 30 mA) must be used for protection of socket outlets with rated current ≤ 20 A in all locations. The use of such RCDs is also recommended in the following cases:

- Socket-outlet circuits in wet locations at all current ratings
  - Socket-outlet circuits in temporary installations
  - Circuits supplying laundry rooms and swimming pools
  - Supply circuits to work-sites, caravans, pleasure boats, and travelling fairs
- See 2.2 and chapter P, al section 3

(1) The tables are those shown in Sub-clause 6.2 (Figures F41 to F44). However, the table of correction factors (Figure F57) which takes into account the ratio S<sub>ph</sub>/SPE, and of the type of circuit (3-ph 3-wire; 3-ph 4-wire; 1-ph 2-wire) as well as conductor material, is specific to the IT system, and differs from that for TN.

## 7.4 Protection in high fire-risk locations

Protection by a RCD of sensitivity  $\leq 500$  mA at the origin of the circuit supplying the fire-risk locations is mandatory in some countries (see Fig. F59).

A preferred sensitivity of 300 mA may be adopted.

## 7.5 When the fault current-loop impedance is particularly high

When the earth-fault current is restricted due to an inevitably high fault-loop impedance, so that the overcurrent protection cannot be relied upon to trip the circuit within the prescribed time, the following possibilities should be considered:

### Suggestion 1 (see Fig. F60)

■ Install a circuit-breaker which has an instantaneous magnetic tripping element with an operation level which is lower than the usual setting, for example:

$$2I_n \leq I_{rm} \leq 4I_n$$

This affords protection for persons on circuits which are abnormally long. It must be checked, however, that high transient currents such as the starting currents of motors will not cause nuisance trip-outs.

- Schneider Electric solutions
- Compact NSX with G trip unit or Micrologic trip unit ( $2I_m \leq I_{rm} \leq 4I_m$ )
- Type B Multi 9 circuit-breaker

### Suggestion 2 (see Fig. F61)

Install a RCD on the circuit. The device does not need to be highly-sensitive (HS) (several amps to a few tens of amps). Where socket-outlets are involved, the particular circuits must, in any case, be protected by HS ( $\leq 30$  mA) RCDs; generally one RCD for a number of socket outlets on a common circuit.

- Schneider Electric solutions
- RCD Multi 9 NG125 :  $I_{\Delta n} = 1$  or 3 A
- Vigicomact MH or ME :  $I_{\Delta n} = 3$  to 30 A

### Suggestion 3

Increase the size of the PE conductors and/or the phase conductors, to reduce the loop impedance.

### Suggestion 4 (see Fig. F62)

Add supplementary equipotential conductors. This will have a similar effect to that of suggestion 3, i.e. a reduction in the earth-fault-loop resistance, while at the same time improving the existing touch-voltage protection measures. The effectiveness of this improvement may be checked by a resistance test between each exposed conductive part and the local main protective conductor.

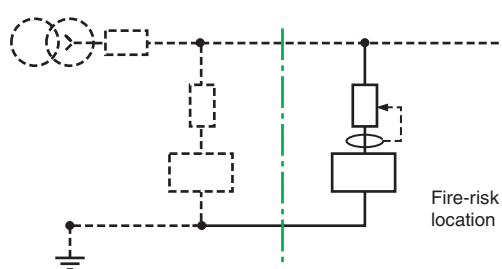

Fig. F59 : Fire-risk location

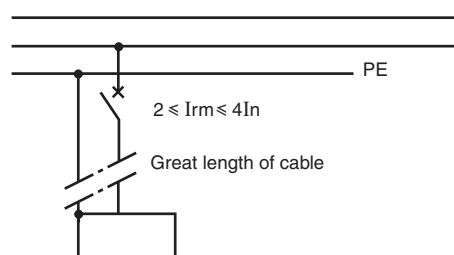

Fig. F60 : A circuit-breaker with low-set instantaneous magnetic trip

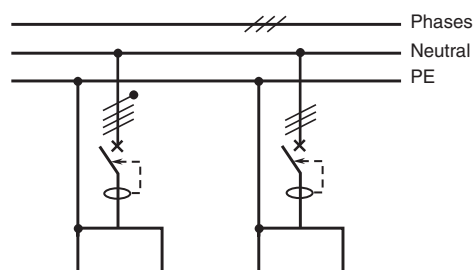

Fig. F61 : RCD protection

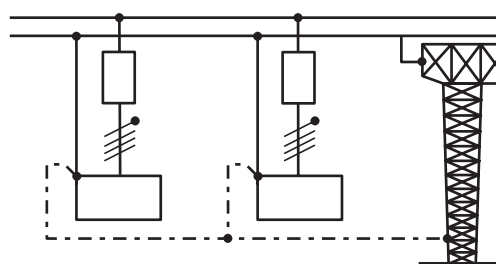

Fig. F62 : Improved equipotential bonding

F35

# 8 Residual current devices (RCDs)

## 8.1 Types of RCDs

Residual current devices (RCD) are commonly incorporated in or associated with the following components:

- Industrial-type moulded-case circuit-breakers (MCCB) and air circuit-breakers (ACB) conforming to IEC 60947-2 and its appendix B and M
- Industrial type miniature circuit-breakers (MCB) conforming to IEC 60947-2 and its appendix B and M
- Household and similar miniature circuit-breakers (MCB) complying with IEC 60898, IEC 61008, IEC 61009
- Residual load switch conforming to particular national standards
- Relays with separate toroidal (ring-type) current transformers, conforming to IEC 60947-2 Appendix M

RCDs are mandatorily used at the origin of TT-earthed installations, where their ability to discriminate with other RCDs allows selective tripping, thereby ensuring the level of service continuity required.

F36

Industrial circuit-breakers with an integrated RCD are covered in IEC 60947-2 and its appendix B

### Industrial type circuit-breakers with integrated or adaptable RCD module (see Fig. F63)



Industrial type circuit-breaker  
Vigi Compact

Multi 9 DIN-rail industrial  
Circuit-breaker with adaptable Vigi RCD module

Fig. F63 : Industrial-type CB with RCD module

Adaptable residual current circuit-breakers, including DIN-rail mounted units (e.g. Compact or Multi 9), are available, to which may be associated an auxiliary RCD module (e.g. Vigi).

The ensemble provides a comprehensive range of protective functions (isolation, protection against short-circuit, overload, and earth-fault).

Household or domestic circuit-breakers with an integrated RCD are covered in IEC 60898, IEC 61008 and IEC 61009

### Household and similar miniature circuit-breakers with RCD (see Fig. F64)

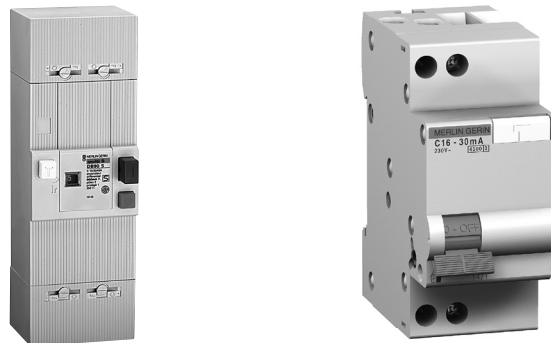

The incoming-supply circuit-breaker can also have time-delayed characteristics and integrate a RCD (type S).

"Monobloc" Déclit Vigi residual current circuit-breakers intended for protection of terminal socket-outlet circuits in domestic and tertiary sector applications.

Fig. F64 : Domestic residual current circuit-breakers (RCCBs) for earth leakage protection

## 8 Residual current devices (RCDs)

Residual current load break switches are covered by particular national standards. RCDs with separate toroidal current transformers are standardized in IEC 60947-2 appendix M

### Residual current circuit-breakers and RCDs with separate toroidal current transformer (see Fig. F65)

RCDs with separate toroidal CTs can be used in association with circuit-breakers or contactors.



Fig. F65 : RCDs with separate toroidal current transformers (Vigirex)

F37

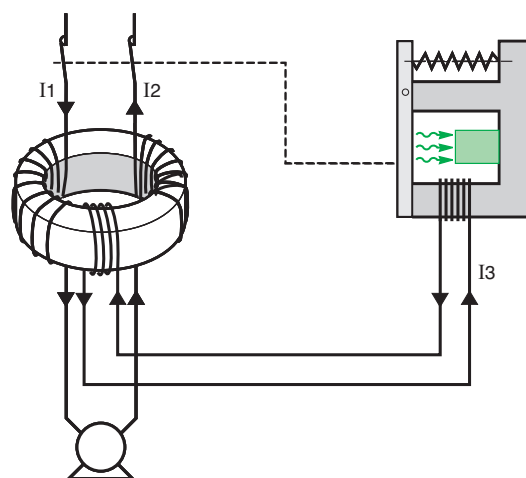

Fig. F66 : The principle of RCD operation

### 8.2 Description

#### Principle

The essential features are shown schematically in Figure F66 below.

A magnetic core encompasses all the current-carrying conductors of an electric circuit and the magnetic flux generated in the core will depend at every instant on the arithmetical sum of the currents; the currents passing in one direction being considered as positive ( $I_1$ ), while those passing in the opposite direction will be negative ( $I_2$ ).

In a normally healthy circuit  $I_1 + I_2 = 0$  and there will be no flux in the magnetic core, and zero e.m.f. in its coil.

An earth-fault current  $I_d$  will pass through the core to the fault, but will return to the source via the earth, or via protective conductors in a TN-earthed system.

The current balance in the conductors passing through the magnetic core therefore no longer exists, and the difference gives rise to a magnetic flux in the core.

The difference current is known as the “residual” current and the principle is referred to as the “residual current” principle.

The resultant alternating flux in the core induces an e.m.f. in its coil, so that a current  $I_3$  flows in the tripping-device operating coil. If the residual current exceeds the value required to operate the tripping device either directly or via an electronic relay, then the associated circuit-breaker will trip.

### 8.3 Sensitivity of RCDs to disturbances

In certain cases, aspects of the environment can disturb the correct operation of RCDs:

- **“nuisance” tripping:** Break in power supply without the situation being really hazardous. This type of tripping is often repetitive, causing major inconvenience and detrimental to the quality of the user's electrical power supply.
- **non-tripping, in the event of a hazard.** Less perceptible than nuisance tripping, these malfunctions must still be examined carefully since they undermine user safety. This is why international standards define 3 categories of RCDs according to their immunity to this type of disturbance (see below).

F38

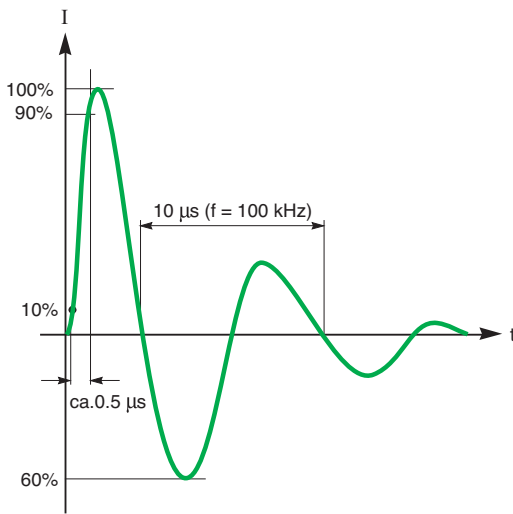

Fig. F67 : Standardized 0.5 μs/100 kHz current transient wave

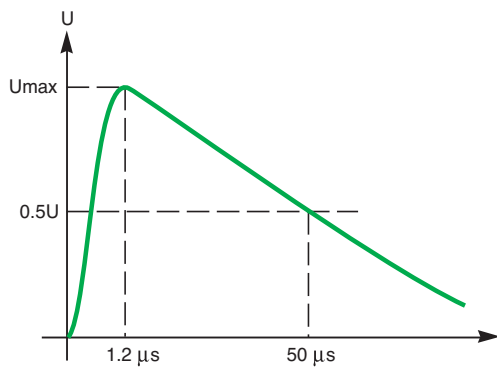

Fig. F68 : Standardized 1.2/50 μs voltage transient wave

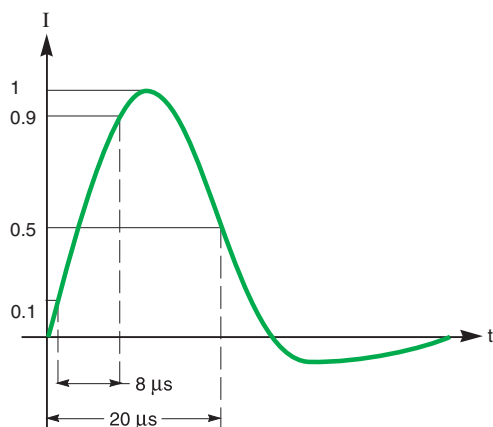

Fig. F69 : Standardized current-impulse wave 8/20 μs

## Main disturbance types

### Permanent earth leakage currents

Every LV installation has a permanent leakage current to earth, which is either due to:

- Unbalance of the intrinsic capacitance between live conductors and earth for three-phase circuits or
  - Capacitance between live conductors and earth for single-phase circuits
- The larger the installation the greater its capacitance with consequently increased leakage current.

The capacitive current to earth is sometimes increased significantly by filtering capacitors associated with electronic equipment (automation, IT and computer-based systems, etc.).

In the absence of more precise data, permanent leakage current in a given installation can be estimated from the following values, measured at 230 V 50 Hz:

Single-phase or three-phase line: 1.5 mA /100m

- Heating floor: 1mA / kW
- Fax terminal, printer: 1 mA
- Microcomputer, workstation: 2 mA
- Copy machine: 1.5 mA

Since RCDs complying with IEC and many national standards may operate under the limitation of permanent leakage current to 0.25 I n, by sub-division of circuits will, in practice, eliminate any unwanted tripping.

For very particular cases, such as the extension, or partial renovation of extended IT-earthed installations, the manufacturers must be consulted.

**High frequency components** (harmonics, transients, etc.), are generated by computer equipment power supplies, converters, motors with speed regulators, fluorescent lighting systems and in the vicinity of high power switching devices and reactive energy compensation banks.

Part of these high frequency currents may flow to earth through parasitic capacitances. Although not hazardous for the user, these currents can still cause the tripping of differential devices.

### Energization

The initial energization of the capacitances mentioned above gives rise to high frequency transient currents of very short duration, similar to that shown in **Figure F67**.

The sudden occurrence of a first-fault on an IT-earthed system also causes transient earth-leakage currents at high frequency, due to the sudden rise of the two healthy phases to phase/phase voltage above earth.

### Common mode overvoltages

Electrical networks are subjected to overvoltages due to lightning strikes or to abrupt changes of system operating conditions (faults, fuse operation, switching, etc.). These sudden changes often cause large transient voltages and currents in inductive and capacitive circuits. Records have established that, on LV systems, overvoltages remain generally below 6 kV, and that they can be adequately represented by the conventional 1.2/50 μs impulse wave (see **Fig. F68**).

These overvoltages give rise to transient currents represented by a current impulse wave of the conventional 8/20 μs form, having a peak value of several tens of amperes (see **Fig. F69**).

The transient currents flow to earth via the capacitances of the installation.

### Non-sinusoidal fault currents

#### Type AC, A, B

Standard IEC 60755 (General requirements for residual current operated protective devices) defines three types of RCD depending on the characteristics of the fault current:

- Type AC  
RCD for which tripping is ensured for residual sinusoidal alternating currents.
- Type A  
RCD for which tripping is ensured:
  - for residual sinusoidal alternating currents,
  - for residual pulsating direct currents,

# 8 Residual current devices (RCDs)

■ **Type B**

RCD for which tripping is ensured:

- as for type A,
- for pure direct residual currents which may result from three-phase rectifying circuits.

**Cold:** in the cases of temperatures under - 5 °C, very high sensitivity electromechanical relays in the RCD may be “welded” by the condensation – freezing action.

Type “Si” devices can operate under temperatures down to - 25 °C.

**Atmospheres with high concentrations of chemicals or dust:** the special alloys used to make the RCDs can be notably damaged by corrosion. Dust can also block the movement of mechanical parts.

See the measures to be taken according to the levels of severity defined by standards in **Fig. F70**.

Regulations define the choice of earth leakage protection and its implementation. The main reference texts are as follows:

■ **Standard IEC 60364-3:**

- This gives a classification (AFx) for external influences in the presence of corrosive or polluting substances.
- It defines the choice of materials to be used according to extreme influences.

F39

<b>Disturbed network</b>	Super-immunized residual current protections <b>Type A if:</b>	SiE  residual current protections	SiE  residual current protections	SiE  residual current protections
	<b>Influence of the electrical network</b>		+	+
<b>Clean network</b>	Standard immunized residual current protections <b>Type AC</b>		Appropriate additional protection (sealed cabinet or unit)	Appropriate additional protection (sealed cabinet or unit + overpressure)
	<b>AF1</b>	<b>AF2</b>	<b>AF3</b>	<b>AF4</b>
	<ul style="list-style-type: none"> <li>■ External influences: negligible,</li> <li>■ Equipment characteristics: normal.</li> </ul>	<ul style="list-style-type: none"> <li>■ External influences: presence of corrosive or polluting atmospheric agents,</li> <li>■ Equipment characteristics: e.g. conformity with salt mist or atmospheric pollution tests.</li> </ul>	<ul style="list-style-type: none"> <li>■ External influences: intermittent or accidental action of certain common chemicals,</li> <li>■ Equipment characteristics: corrosion protection.</li> </ul>	<ul style="list-style-type: none"> <li>■ External influences: permanent action of corrosive or polluting chemicals</li> <li>■ Equipment characteristics: specifically studied according to the type of products.</li> </ul>

Examples of exposed sites	External influences
Iron and steel works.	Presence of sulfur, sulfur vapor, hydrogen sulfide.
Marinas, trading ports, boats, sea edges, naval shipyards.	Salt atmospheres, humid outside, low temperatures.
Swimming pools, hospitals, food & beverage.	Chlorinated compounds.
Petrochemicals.	Hydrogen, combustion gases, nitrogen oxides.
Breeding facilities, tips.	Hydrogen sulfide.

**Fig. F70 :** External influence classification according to IEC 60364-3 standard

**Immunity level for Merlin Gerin residual current devices**

The Merlin Gerin range comprises various types of RCDs allowing earth leakage protection to be adapted to each application. The table below indicates the choices to be made according to the type of probable disturbances at the point of installation.

Device type	Nuisance trippings	Non-trippings			
	High frequency leakage current	Fault current		Low temperatures (down to - 25 °C)	Corrosion Dust
		Rectified alternating	Pure direct		
AC	■				
A	■	■		■	
SI	■ ■ ■	■		■	
SiE	■ ■ ■	■		■	■
B	■ ■ ■	■	■	■	

Fig. F71 : Immunity level of Merlin Gerin RCDs

**Immunity to nuisance tripping**

Type Si/SiE RCDs have been designed to avoid nuisance tripping or non-tripping in case of polluted network , lightning effect, high frequency currents, RF waves, etc. **Figure F72** below indicates the levels of tests undergone by this type of RCDs.

Disturbance type	Rated test wave	Immunity
<b>Multi9 : ID-RCCB, DPN Vigi, Vigi C60, Vigi C120, Vigi NG125 SI / SiE type</b>		
<b>Continuous disturbances</b>		
Harmonics	1 kHz	Earth leakage current = 8 x I n
Transient disturbances		
Lightning induced overvoltage	1.2 / 50 µs pulse (IEC/EN 61000-4-5)	4.5 kV between conductors 5.5 kV / earth
Lightning induced current	8 / 20 µs pulse (IEC/EN 61008)	5 kA peak
Switching transient, indirect lightning currents	0.5 µs / 100 kHz " ring wave " (IEC/EN 61008)	400 A peak
Downstream surge arrester operation, capacitance loading	10 ms pulse	500 A
<b>Electromagnetic compatibility</b>		
Inductive load switchings fluorescent lights, motors, etc.)	Repeated bursts (IEC 61000-4-4)	4 kV / 400 kHz
Fluorescent lights, thyristor controlled circuits, etc.	RF conducted waves (IEC 61000-4-6)	66 mA (15 kHz to 150 kHz) 30 V (150 kHz to 230 MHz)
RF waves (TV& radio, broadcast, telecommunications,etc.)	RF radiated waves 80 MHz to 1 GHz (IEC 61000-4-3)	30 V / m

Fig. F72 : Immunity to nuisance tripping tests undergone by Merlin Gerin RCDs

F40



## 8 Residual current devices (RCDs)

### Recommendations concerning the installation of RCDs with separate toroidal current transformers

The detector of residual current is a closed magnetic circuit (usually circular) of very high magnetic permeability, on which is wound a coil of wire, the ensemble constituting a toroidal (or ring-type) current transformer.

Because of its high permeability, any small deviation from perfect symmetry of the conductors encompassed by the core, and the proximity of ferrous material (steel enclosure, chassis members, etc.) can affect the balance of magnetic forces sufficiently, at times of large load currents (motor-starting current, transformer energizing current surge, etc.) to cause unwanted tripping of the RCD.

Unless particular measures are taken, the ratio of operating current  $I\Delta n$  to maximum phase current  $I_{ph}$  (max.) is generally less than 1/1,000.

This limit can be increased substantially (i.e. the response can be desensitized) by adopting the measures shown in **Figure F73**, and summarized in **Figure F74**.

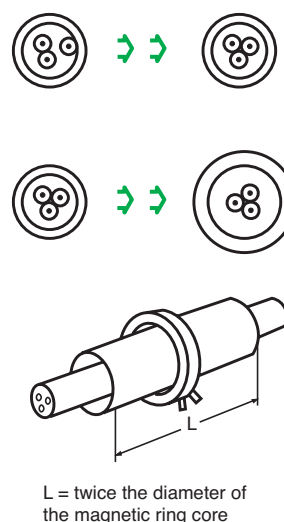

**Fig. F73** : Three measures to reduce the ratio  $I\Delta n/I_{ph}$  (max.)

Measures	Diameter (mm)	Sensitivity diminution factor
Careful centralizing of cables through the ring core		3
Oversizing of the ring core	$\varnothing 50 \rightarrow \varnothing 100$	2
	$\varnothing 80 \rightarrow \varnothing 200$	2
	$\varnothing 120 \rightarrow \varnothing 300$	6
Use of a steel or soft-iron shielding sleeve	$\varnothing 50$	4
■ Of wall thickness 0.5 mm	$\varnothing 80$	3
■ Of length 2 x inside diameter of ring core	$\varnothing 120$	3
■ Completely surrounding the conductors and overlapping the circular core equally at both ends	$\varnothing 200$	2

These measures can be combined. By carefully centralizing the cables in a ring core of 200 mm diameter, where a 50 mm core would be large enough, and using a sleeve, the ratio 1/1,000 could become 1/30,000.

**Fig. F74** : Means of reducing the ratio  $I\Delta n/I_{ph}$  (max.)

F41

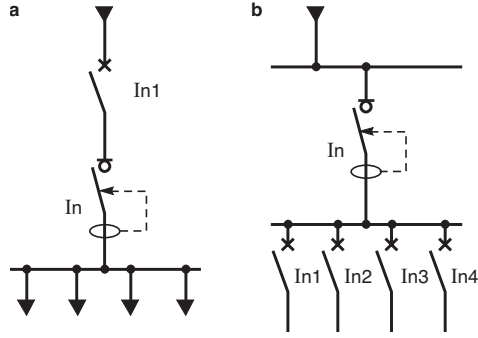

### Choice of characteristics of a residual-current circuit-breaker (RCCB - IEC 61008)

#### Rated current

The rated current of a RCCB is chosen according to the maximum sustained load current it will carry.

■ If the RCCB is connected in series with, and downstream of a circuit-breaker, the rated current of both items will be the same, i.e.  $I_n \geq I_{n1}$  (see Fig. F75a)

■ If the RCCB is located upstream of a group of circuits, protected by circuit-breakers, as shown in Figure F75b, then the RCCB rated current will be given by:

$$I_n \geq k_u \times k_s (I_{n1} + I_{n2} + I_{n3} + I_{n4})$$

#### Electrodynamic withstand requirements

Protection against short-circuits must be provided by an upstream SCPD (Short-Circuit Protective Device) but it is considered that where the RCCB is located in the same distribution box (complying with the appropriate standards) as the downstream circuit-breakers (or fuses), the short-circuit protection afforded by these (outgoing-circuit) SCPDs is an adequate alternative. Coordination between the RCCB and the SCPDs is necessary, and manufacturers generally provide tables associating RCCBs and circuit-breakers or fuses (see Fig. F76).

F42

Fig. F75 : Residual current circuit-breakers (RCCBs)

Circuit-breaker and RCCB association – maxi I<sub>sc</sub> (r.m.s) value in kA

Upstream circuit-breaker		DT40	DT40N	C60N	C60H	C60L	C120N	C120H	NG125N	NG125H	
Downstream RCCB	2P	I 20A	6.5	6.5	6.5	6.5	3	4.5	4.5	4.5	
	230V	IN-A 40A	6	10	20	30	30	10	10	15	15
		IN-A 63A	6	10	20	30	30	10	10	15	15
		I 100A						15	15	15	15
4P	I 20A	4.5	4.5	4.5	4.5	4.5	2	3	3	3	
	400V	IN-A 40A	6	10	10	15	15	7	7	15	15
		IN-A 63A	6	10	10	15	15	7	7	15	15
		NG 125NA						10	16	25	50

Fuses and RCCB association – maxi I<sub>sc</sub> (r.m.s) value in kA

gG upstream fuse		20A	63A	100A	125A
Downstream RCCB	2P	I 20A	8		
	230V	IN-A 40A		30	20
		IN-A 63A		30	20
		I 100A			6
4P	I 20A	8			
	400V	IN-A 40A		30	20
		IN-A 63A		30	20
		NG 125NA			

Fig. F76 : Typical manufacturers coordination table for RCCBs, circuit-breakers, and fuses (Merlin Gerin products)