



# SUSTAINABLE STANFORD

A YEAR IN REVIEW

2009–2010





*If we are to leave our children a better world, we must take steps now to create a sustainable environment. So it is critical that we model sustainable citizenship on our own campus.*

— JOHN ETCHEMENDY, PROVOST  
STANFORD UNIVERSITY

*Sustainability must become a core value in everything we do. As a community we are committed to developing our core campus in a sustainable fashion that preserves what we cherish, that demonstrates leadership in the university's commitment to be a good environmental steward and that safeguards the ability for future generations to thrive at Stanford.*

— JOHN L. HENNESSY, PRESIDENT  
STANFORD UNIVERSITY

## Welcome Message

Greetings from Stanford's Office of Sustainability! We are pleased to present the 2009–2010 edition of **Sustainable Stanford—A Year in Review**, which showcases the many strides forward in institutionalizing sustainability made this year.

Our university has been a leader in environmental sustainability for decades. In recent years, Stanford has multiplied its efforts to make itself sustainable for the future. We have made key advances in the concept, design, construction, and operation of the campus so it is built to last, while reducing its environmental footprint. We have also started to lay the foundations for the campus community to experience the full wisdom of sustainability—the balance of economic, environmental, and societal benefits of coexisting with the natural world.

Sustainability is no longer merely an efficiency metric at Stanford. Integrated in academics, operations, communications, and events, sustainability as a core value is transcending infrastructural achievements and is now observable in the campus culture and community. Many schools and departments now consciously incorporate sustainability into their operations.

This publication is a chronological snapshot of various initiatives and accomplishments in this arena by academic and operational departments. Some initiatives are mature, others new. Some programs are intended for long-term implementation, while others meet an immediate need. All are strategic and collaborative parts of the integrated and flourishing culture of sustainability at Stanford.

As you consider the stories presented in the pages that follow, you will see how many of them already balance economic, environmental, and societal aspects of sustainability. Our office's work will continue to support each initiative so it can achieve its full potential and broaden the horizon of sustainability at Stanford.

Sincerely,

The Office of Sustainability

## TOPIC AREA GUIDE



Behavior



Buildings



Climate Action



Community Outreach



Energy



Evaluations



Events



Food



Investments



Land



Purchasing



Research



Students



Sustainable IT



Transportation



Waste



Water

## TABLE OF CONTENTS

Welcome Message	1
Topic Area Guide	2
Leadership in Sustainability	4
Year in Review	11
August 2009	13
September 2009	17
October 2009	21
November 2009	30
December 2009	35
January 2010	39
February 2010	43
March 2010	47
April 2010	51
May 2010	59
June 2010	63
July 2010	72
August 2010	79
Program Awards and Recognition	88
Index	93
Acknowledgements	100

## LEADERSHIP IN SUSTAINABILITY

The Department of Sustainability and Energy Management (SEM) leads initiatives in campus infrastructure and programs in the areas of energy and climate, water, transportation, green buildings, and sustainable information technology, as well as various special initiatives. The Office of Sustainability connects campus organizations and entities and works collaboratively with them to steer sustainability initiatives to fulfill President Hennessy's vision that sustainability will become a core value in everything we do. The office works on long-range sustainability analysis and planning, evaluations and reporting, communication and outreach, academic integration, conservation behavior and training, and sustainability governance strategy.

Major support for these efforts is provided by various operational units within Land, Buildings and Real Estate (LBRE), Residential & Dining Enterprises, Stanford Recycling Center (run by Peninsula Sanitary Service, Inc., PSSI), University Communications, Government and Community Relations, Woods Institute for the Environment, Precourt Institute for Energy, School of Medicine, Graduate School of Business, School of Earth Sciences, Alumni Association, and numerous student organizations. From utilities to food systems, there are hundreds of professionals throughout the Stanford community who are involved with sustainability projects in their daily work. The full-time sustainability professionals are listed below, organized by group name.

### Department of Sustainability and Energy Management



#### Joseph Stagner

Executive Director, SEM

[jstagner@stanford.edu](mailto:jstagner@stanford.edu)

Joe leads the Sustainability and Energy Management Department, which includes 90 staff members in Utilities, Parking & Transportation, Business Services, and the Office of Sustainability. He co-chairs the Sustainability Working Group and leads the university's long-range sustainability infrastructure planning and implementation.

## SUSTAINABILITY OFFICE



#### Fahmida Ahmed

Associate Director, Office of Sustainability, SEM

[fahmida@stanford.edu](mailto:fahmida@stanford.edu)

Fahmida leads the Office of Sustainability and the campus program Sustainable Stanford. She co-chairs the Sustainability Working Group, connects the Sustainability Working Teams, coordinates implementation of sustainability projects, supports Stanford's long-term resource infrastructure planning, and manages the office's communications and evaluation programs.



#### Jiffy Vermylen

Sustainability Coordinator, Office of Sustainability, SEM

[jiffy.vermylen@stanford.edu](mailto:jiffy.vermylen@stanford.edu)

Jiffy supports further development and implementation of the campus-wide Sustainable Stanford initiative. Her portfolio includes roll-outs of the department/building-level conservation programs, related communications with and training for the campus community, and overall program evaluation standards and criteria, especially for the built environment.



#### Elsa Baez

Staff Assistant, SEM

[elsab@stanford.edu](mailto:elsab@stanford.edu)

Elsa supports the communication and outreach efforts of the Sustainable Stanford program. She also coordinates the Office of Sustainability's events and sustainability tours.

## ENERGY MANAGEMENT

### Energy Services



#### Robert Reid

Associate Director, Energy Services, SEM

[Robert.Reid@stanford.edu](mailto:Robert.Reid@stanford.edu)

Robert manages energy services at Stanford, which entails the production of electricity, steam, and chilled water supplies on campus. His role includes oversight of the procurement and production of those commodities as well as mechanical operations of the Central Energy Facility.

## Power Systems



### Rich Bitting

Associate Director, Power Systems, SEM  
[rbitting@stanford.edu](mailto:rbitting@stanford.edu)

Rich directs the Power Systems department, which includes responsibility for the campus electrical distribution system and street lights. Within the department, a staff of engineers, supervisors, and technicians ensures that the campus has an efficient and reliable supply of electricity.

## Thermal Energy Distribution



### Dean Murray

Associate Director, Steam Systems, SEM  
[deanm@bonair.stanford.edu](mailto:deanm@bonair.stanford.edu)

Dean manages the steam, hot water, and chilled water underground piping system distribution. His department includes steamfitters, the Steam Shop supervisor, and engineers for the distribution piping systems. Dean ensures delivery of heating and cooling services to academic buildings, housing and dining facilities, athletic facilities, and the Stanford Medical Center.

## Facilities Energy Management



### Gerry Hamilton

Associate Director, Facilities Energy Management, SEM  
[gerryh@stanford.edu](mailto:gerryh@stanford.edu)

Gerry directs the activities of Stanford's Facilities Energy Management (FEM) program, including the operation of campus building energy management systems, oversight of the university's Sustainable IT program, and supervision of building energy retrofit projects. The program ensures that buildings and associated processes are operated efficiently and that new facilities incorporate best practices for energy use



### Joyce Dickerson

Director, Sustainable IT, SEM  
[jdickerson@stanford.edu](mailto:jdickerson@stanford.edu)

Joyce leads Sustainable IT, the university-wide effort to reduce carbon emissions associated with computing infrastructure. Her focus includes personal, administrative, and high-performance computing, and targets equipment from desktops to data centers. Joyce functions as a liaison between LBRE and

IT Services to develop integrated solutions for energy efficiency challenges. She also works with departments campus-wide to identify and implement Sustainable IT programs.



### Scott Gould

Senior Energy Engineer, Facilities Energy Management, SEM  
[scottg@bonair.stanford.edu](mailto:scottg@bonair.stanford.edu)

Scott manages the Whole Building Retrofit Program and the Energy Retrofit Program. Scott leads the renewable energy projects on campus, including a study of the total potential for photovoltaics (PVs) and installation of solar thermal systems, including the 30kW PV system at Reservoir 2 in the Stanford foothills and the 40kW PV system at the Hoover House.



### Susan Kulakowski-Vargas

Manager, Demand-Side Energy, SEM  
[susank@stanford.edu](mailto:susank@stanford.edu)

Susan works to improve the energy performance of the university's 15 million square feet of existing buildings. Susan administers the Energy Conservation Incentive Program (ECIP) to promote conservation and sustainable procurement. She oversees both a \$1 million program and a \$15 million capital program to identify, coordinate, and fund efficiency retrofit projects.



### Shalini Singh

Energy Engineer, Facilities Energy Management, SEM  
[singhsha@stanford.edu](mailto:singhsha@stanford.edu)

Shalini supports the conservation and technology efficiency projects across Stanford's existing building portfolio. She supports implementation of the Energy Retrofit Program and the Whole Building Retrofit Program. Shalini works across groups in Zone Management, Building Energy Systems, and Operations to align energy efficiency goals.

## WATER SERVICES AND CIVIL INFRASTRUCTURE



### Tom Zigterman

Associate Director, Water Services & Civil Infrastructure, SEM  
[twz@stanford.edu](mailto:twz@stanford.edu)

Tom manages a group of engineers, scientists, and water technicians who are responsible for operation of Stanford's water supplies, including domestic water, surface water, wastewater, and storm drainage systems, as well as other

civil infrastructure, including dams, bridges, and roads. He also chairs the Water Sustainability Working Team, which is currently planning the long-term sustainable management of Stanford's water supply and demand.



**Marty Laporte**

Associate Director, Environmental Quality & Water Conservation, SEM

[martyl@bonair.stanford.edu](mailto:martyl@bonair.stanford.edu)

Marty manages Stanford's Environmental Quality and Compliance Program for campus waters, wastewater, soils, Facilities and Utilities hazardous materials, and underground storage tanks. She also manages Stanford's Water

Conservation Program, which tests new technology, including high-efficiency fixtures, and oversees the implementation of campus-wide upgrades and new building water efficiency standards.

**TRANSPORTATION**



**Brodie Hamilton**

Director, Parking & Transportation Services, SEM

[brodie.hamilton@stanford.edu](mailto:brodie.hamilton@stanford.edu)

Brodie leads Stanford's transportation programs, which include parking and retail operations, an award-winning transportation demand management program, a bicycle program, the Marguerite Shuttle service, charter services, transportation program planning and development,

and marketing communications. He is a member of Stanford's Sustainability Working Group.



**Lisa Kwiatkowski**

Manager, Transportation Demand Management and Outreach, SEM

[lisakwi@stanford.edu](mailto:lisakwi@stanford.edu)

Lisa leads the marketing and communications efforts for Stanford's Parking & Transportation Services department, with a focus on promoting alternative transportation through Stanford's Commute Club and other incentive programs.

These efforts helped reduce the university's employee drive-alone rate from 72% in 2002 to 48% in 2010.



**Ariadne Scott**

Bicycle Program Coordinator, Parking & Transportation Services, SEM

[adscott@stanford.edu](mailto:adscott@stanford.edu)

Ariadne leads the bicycle program for Stanford's 8,000-acre campus, which is designated a Gold Level Bicycle Friendly Community (2008–2011) by the League of American Bicyclists (LAB). She is LAB Road 1 certified, co-teaches bike safety

classes, lives "car free," and supports and encourages student bicyclists and the 18% of employees who bike-commute to and from Stanford.

**Residential & Dining Enterprises**



**Matt Rothe**

Sustainability Coordinator, Stanford Dining Services

[mrothe@stanford.edu](mailto:mrothe@stanford.edu)

Matt works closely with other employees of Stanford Dining on sustainable food procurement, waste reduction, on-campus food production, and creating awareness through events and educational opportunities. He also manages student gardeners and interns, assists faculty with classes

related to food and agriculture, and coordinates with other staff to promote sustainable initiatives.

**School of Earth Sciences**



**Sarah Wiederkehr**

Farm Educator, Earth Systems

[swied@stanford.edu](mailto:swied@stanford.edu)

Sarah teaches a number of sustainable agriculture courses for Stanford's Earth Systems program. She manages the teaching space at the Stanford Farm and is actively involved with student gardening organizations on campus, including the Dining Hall Garden Initiative and the student-run

Campus Gardening Initiative.

## Campus Planning and Design



### **Catherine Deino Blake**

Associate Director, University Architect/Campus Planning & Design

[cathyb@stanford.edu](mailto:cathyb@stanford.edu)

Cathy directs landscape design and site furnishings at Stanford, including the preparation of campus plans, design guidelines, and campus standards. She provides input into and reviews all major capital project designs and develops conceptual designs for campus projects including landscape plantings, malls, courtyards, and plazas; vehicular, bike, and pedestrian travel; and parking.



### **Eva Rose Leavitt**

Campus Planner, University Architect/Campus Planning & Design

[eval@stanford.edu](mailto:eval@stanford.edu)

Eva supports the development of site and design guidelines for new buildings, landscape plans for small projects, implementation of campus furnishing and paving systems, and advocacy of responsible stewardship of the land through sustainable design. She works with the Campus Landscape Architect on the implementation of outdoor infrastructure programs.

## Peninsula Sanitary Service, Inc.



### **Julie Muir**

Community Relations Manager, PSSI / Stanford Recycling Center

[juliem@pssi.stanford.edu](mailto:juliem@pssi.stanford.edu)

Julie leads the construction and demolition waste diversion program and the food waste collection and composting program. She also continues to expand the campus recycling services. She advocates for a zero-waste campus through a comprehensive program of waste reduction, reuse, recycling, composting, and sustainable purchasing. Julie has led over 20 audits of campus trash to provide the Stanford community with meaningful data to improve targeted waste reduction.

# Sustainable Stanford

## A Year in Review

### August 2009–August 2010



This report is produced by the Office of Sustainability as one of the many deliverables that make sustainability a tangible part of the Stanford experience. Beyond an annual report, this publication catalogs the many efforts within a large campus that contribute to a steady pulse of sustainability milestones and accomplishments.

Printed for limited distribution, this report is also available on our campus website, [http://sustainable.stanford.edu/publications\\_and\\_reports](http://sustainable.stanford.edu/publications_and_reports).

## Stanford Ranked Among Discovery Communications' 10 Greenest Colleges

[TreeHugger](http://www.treehugger.com/), a Discovery Communications company, ranked Stanford among the 10 Greenest Colleges in the United States. Other colleges in the top tier included Yale University, Tufts University, Middlebury College, University of Washington, University of Colorado-Boulder, University of New Hampshire, Warren Wilson College, University of Washington, University of Oregon-Eugene, and College of the Atlantic. According to the company overview, "Discovery Communications is considered the world's number one nonfiction media company, reaching more than 1.5 billion cumulative subscribers in over 180 countries. Discovery empowers people to explore their world and satisfy their curiosity through 100-plus worldwide networks, led by Discovery Channel, TLC, Animal Planet, Science Channel, Investigation Discovery, Planet Green and HD Theater, as well as leading consumer and educational products and service, and a diversified portfolio of digital media services." A [slideshow](#) of the Top 10 Greenest Colleges is available online. This third-party evaluation was conducted by the evaluator alone based on publicly available information.

### More Information:

<http://www.treehugger.com/>

<http://corporate.discovery.com/>







## Stanford Hosts and Helps Green the 2009 Summer National Senior Games

In partnership with Athletics, PSSI, and Parking & Transportation Services, and leveraging the momentum of “greening” events throughout campus, the [2009 Summer National Senior Games](#) developed many sustainability strategies long before the 20,000+ athletes, families, and friends set foot on campus. Most notably, installation of several new hydration stations provided safe drinking water in convenient locations and eliminated the use of multiple plastic water bottles. Athletes and volunteers were provided with one reusable water bottle to fill throughout the games. Other initiatives included free rides on public transportation, electronic transmission of information for athletes, and food vendor commitments to serving meals and drinks in biodegradable containers. The effort to eliminate bottled drinking water is now being considered for other major campus events.



### More Information:

<http://www.2009seniorgames.org/pdf/greenbrochure.pdf>



## Behavioral Sustainability Program Pilot Expands to Departments: IT Services Tackles Nine Buildings

The Department of IT Services rolled out the [Building-Level Sustainability Program](#) (BLSP) to nine buildings, representing the first department-wide program adoption. Thirty-six Green IT Services team members, at least two per building, helped deploy 263 SmartStrips, 55 timers, 22 motion-sensor light switches, and 15 filtered-water coolers. They also set two-thirds of computers to SuperGreen in Stanford’s desktop power management program, which puts the machines into standby mode after 30 minutes of idle time, and set the remaining machines to Green, which turns off monitors after 15 minutes. In a month-to-month comparison with 2008 data, 2009 electricity consumption during the pilot period showed 4%, 5%, 2%, 2%, 16%, and 13% reductions for Pine, Puichon, Redwood, Spruce, Acacia, and Laurel, respectively. Although the percentages may seem small, the high energy intensity in each building translated to a significant 3,224 kWh/month average savings.

### More Information:

[http://sustainable.stanford.edu/buildings\\_initiatives](http://sustainable.stanford.edu/buildings_initiatives)

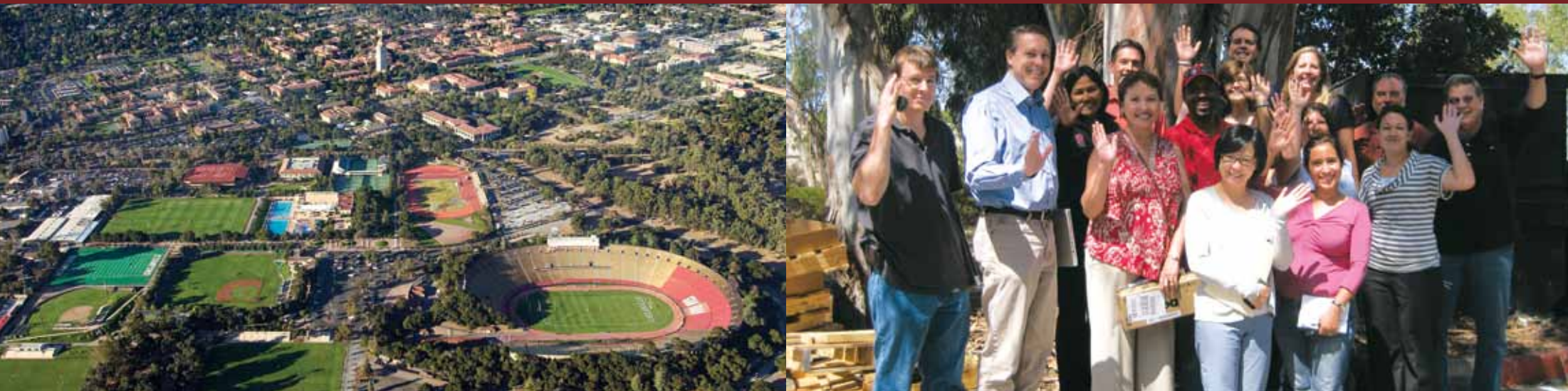

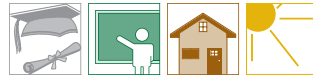

## Students' Residential Solar Water Heater Installation Complete: Data Analysis in Progress

Stanford Solar and Wind Energy Project (SWEP) worked with Utilities and Student Housing for several years to research the effectiveness of residential solar water heating. As a result, Stanford invested in two different collector systems, which were installed on the Robinson and Adams dorms in the summers of 2008 and 2009, respectively. The [Student Green Fund](#) awarded SWEP grant money to purchase Internet-enabled monitoring equipment, including flow, temperature, and solar energy sensors, as well as wireless data loggers. SWEP is currently collecting and analyzing these system data. The analysis will allow SWEP to accurately evaluate the energy and carbon savings of these technologies and to assist future solar endeavors on campus.

### More Information:

<http://inversion.stanford.edu/swep/drupal/>

<http://sustainable.stanford.edu/students>

[http://sustainable.stanford.edu/green\\_fund](http://sustainable.stanford.edu/green_fund)



## Y2E2 Solar Installation Earns Rebate from California Solar Initiative

As a part of the sustainability and educational mission at the Yang and Yamazaki Environment + Energy Building (Y2E2), a 14.5 kW DC photovoltaic system was



installed on the south-facing roof. Three different photovoltaic technologies were installed—monocrystalline, polycrystalline, and thin film—so researchers can evaluate performance characteristics during different sun and temperature conditions. The [California Solar Initiative](#), administered locally by PG&E, offers rebates for new grid-tied photovoltaic systems. After more than two years of diligent documentation, Stanford finally received a check for \$32,151, setting a precedent for future solar installations on campus. The rebate was delivered to the Y2E2 building operation fund to further enhance sustainability within the facility. It represents the first step in realizing the rebate potential of the Science and Engineering Quad (SEQ).

### More Information:

<http://www.gosolarcalifornia.ca.gov/csi/index.php>

[http://sustainable.stanford.edu/green\\_buildings](http://sustainable.stanford.edu/green_buildings)





## Behavioral Sustainability Program Pilot Expands to Arrillaga Alumni Center

An enthusiastic and well-prepared team positioned itself to reach high goals in resource conservation to support its budget plan. The specially recruited “green team” of individuals who work in the center met to discuss ideas and ultimately prepared an all-staff meeting to kick-off the [BLSP](#) pilot. The “Green Fran” presentation highlighted electricity consumption and budget impact, and also educated staff on the volume of consumables used in their daily office life. Key statistics were shared on the use of items such as paper, toner, cups, and bottled water. The team modeled the pilot on the belief that staff education provides motivation for individuals to think and conserve, reducing both costs and landfill waste. In a month-to-month comparison with 2008 data, 2009 electricity consumption during the pilot period fell 8%, contributing to a four-month payback period for investments in SmartStrips and timers. The team is currently preparing to expand the program to its off-campus Palo Alto facility.

**More Information:**

[http://sustainable.stanford.edu/buildings\\_initiatives](http://sustainable.stanford.edu/buildings_initiatives)



## Research: Overuse of Fertilizers May Catalyze Waterborne Diseases

Research at Stanford is focusing on cholera, a disease that affects hundreds of thousands of people worldwide. Gary Schoolnik, professor of medicine and senior fellow at the Woods Institute for the Environment, thinks that the [increased use of fertilizer in developing countries may be fueling the problem](#). Schoolnik’s hypothesis is that runoff from fertilizers can create massive algal blooms. These blooms, in turn, provide food for copepods, tiny shrimp-like crustaceans. The water-borne cholera bacteria then feed on the shells of the copepods, causing their populations to explode. The project remains ongoing, but researchers hope they will be able to work toward finding global predictors of cholera outbreaks.



**More Information:**

<http://woods.stanford.edu/cgi-bin/focal.php?name=cholera>





## Sustainability Featured at New Student Orientation

Held at Memorial Auditorium and organized by the Associated Students of Stanford University (ASSU) and Undergraduate Advising and Research, the Beginnings panel during [New Student Orientation](#) featured sustainability as its central



theme. Offered each year, Beginnings provides an opportunity for new and returning students to hear from alumni and faculty about creating value and meaning during their Stanford experience and beyond. The panel, moderated by President Hennessy, included guest speakers Vinod Khosla, MBA '80, founder of venture capital firm Khosla Ventures, which funds clean-tech efforts; Jeffrey Koseff, Professor of Civil and Environmental Engineering and Director of the [Woods Institute for the Environment](#) at Stanford; Jeff Orlowski, '06, filmmaker; and Jane Woodward, Consulting Associate Professor of Civil and Environmental Engineering and CEO of Mineral Acquisition Partners (MAP). This event also served as the kick-off for the first-ever ASSU Sustainability Chair position.

### More Information:

<http://woods.stanford.edu/>  
[http://ual.stanford.edu/pdf/uar\\_StudentEventsCalendar\\_0910.pdf](http://ual.stanford.edu/pdf/uar_StudentEventsCalendar_0910.pdf)



## Students Install Anemometer Tower in Salinas Valley to Quantify Wind Resource

The Stanford Green Fund awarded [Stanford Solar and Wind Energy Project](#) (SWEP) grants in 2008 and 2009 to site and install a 50-meter anemometer tower to measure the wind resource in the Salinas Valley. The tower was installed in October 2009 with student participation in cooperation with the City of Soledad. SWEP is currently recording and analyzing wind measurements to quantify the potential for a wind-power project. If the wind resource is sufficient to develop a community-scale wind farm, SWEP will develop a project proposal for Stanford to build wind turbines to offset part of its on-campus electricity consumption. Data collection will continue through December 2010 and thus far suggests that a viable wind resource exists and warrants continued investigation. The students discovered a unique pattern in the data with high wind speeds frequent during summer afternoons, which could mean a wind turbine would generate power when it is most needed and most valuable in California.



### More Information:

<http://inversion.stanford.edu/swep/drupal/>  
<http://sustainable.stanford.edu/students>  
[http://sustainable.stanford.edu/green\\_fund](http://sustainable.stanford.edu/green_fund)





## Diesel-Electric Hybrid Buses Join Marguerite Fleet

Stanford added two new diesel-electric hybrid buses to the [Marguerite](#) bus fleet. The new buses are one of the many ways Stanford's award-winning transportation program is reducing Stanford's carbon footprint. The new Marguerite hybrid buses are much quieter and 40% more fuel-efficient than the standard transit-style diesel buses in the fleet. The regenerative braking system kicks in each time the driver lifts his or her foot from the accelerator, helping to recharge the onboard batteries. The regenerative braking system also helps to slow the bus, dramatically extending the life of the brake pads. The transportation of choice for [Sustainability on the Farm Tours](#), the hybrid buses not only showcase Stanford's commitment to emissions reductions, but also provide a business case for fuel-efficient fleet vehicles.

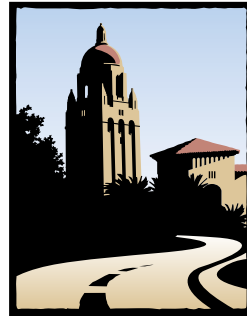

STANFORD UNIVERSITY  
**P&TS**  
Parking & Transportation Services

### More Information:

<http://transportation.stanford.edu/marguerite/>



## Student Sustainability Town Hall Meeting Tradition Continues

Students for a Sustainable Stanford, the ASSU Executive, and the Senate Sustainability Subcommittee collaborated with Residential & Dining Enterprises, Parking & Transportation Services, and the Office of Sustainability to host one of three annual Town Hall meetings. Responding to increased student interest in understanding university operations, the organizers provided the [sustainability-themed Town Hall](#) as an educational opportunity. This was considered one of the most successful Town Hall meetings in recent history. More than 150 students attended to hear university staff and a diverse range of environmentally-focused student groups discuss past, present, and future projects in order to mutually support on-campus sustainability efforts and increase collaboration.



### More Information:

<http://assu.stanford.edu/>





## Stanford in Top Tier on Sustainable Endowments Institute 2010 College Sustainability Report Card

The Sustainable Endowments Institute (SEI) released the annual [College Sustainability Report Card 2010](http://greenreportcard.org/), and Stanford remained in the top tier. Out of 332 institutions surveyed, 26 colleges and universities received the top mark (an "A-") for leadership in sustainability. Stanford has received this rank three times in the last four years. Stanford was recognized as both an "overall college sustainability leader" and a "campus sustainability leader." The survey compilation required efforts by operational departments, research institutes, asset management groups, and various student organizations to highlight all of Stanford's accomplishments in the field of sustainability. Other major research universities recognized with the top grade were Brown University, Harvard University, University of Pennsylvania, and Yale University. The yearly survey continues to be an informative process for the Office of Sustainability and its partners.



### More Information:

<http://greenreportcard.org/>  
<http://www.endowmentinstitute.org/>



## Inaugural Sustainability Tour at Reunion Homecoming Weekend 2009

Over the last few years, Stanford has made Reunion Homecoming an example of the university's sustainability commitment and leadership. Building upon efforts already in place, the Office of Sustainability inaugurated the [Sustainability on the Farm Tour](#), which focuses on operations to provide a flavor of sustainable practices in action. At Reunion Homecoming 2009, alumni were escorted around campus in one of the new hybrid Marguerite buses. Presentations related to each operational area were provided by staff members both on the bus and on-site via a quick walk. Topics included water, waste and recycling, transportation demand management, energy, sustainable landscaping, and sustainability at the Y2E2 building. The alums were deeply engaged with the topics and appreciated the opportunity to learn about Stanford's progress in the sustainability arena. The tour will be offered again at major 2010 campus events.

### More Information:

<http://sustainable.stanford.edu/events>





## Sustainable Information Technology Highlighted at Nationwide EDUCAUSE Conference

The [EDUCAUSE](#) 2009 Annual Conference, held in Denver, featured sustainable IT as the topic for at least a dozen sessions, compared to only a few the prior year. With nearly 5,000 attendees, EDUCAUSE is one of the largest gatherings of higher education IT professionals annually. This year, Stanford led the sustainable IT discussion group and presented “[Sustainable IT at Stanford—A Year in Review](#),” which highlighted Stanford’s 2009 accomplishments with desktop computing, datacenters, and distributed server room efficiency initiatives. Stanford also spoke as the “green IT expert” at EDUCAUSE Online, the Web-only venue with attendees from across the globe. The full presentation, as well as the discussion group topics and notes, is available on the Sustainable IT [webpage](#). Following the successful EDUCAUSE sessions, Stanford was invited to join the advisory panel for the EDUCAUSE Center for Applied Research report, “[Powering Down: Green IT in Higher Education](#).”

**More Information:**

[http://sustainable.stanford.edu/sustainable\\_it](http://sustainable.stanford.edu/sustainable_it)  
<http://www.educause.edu/>



## Self-Service Bike Repair Station Opens on Campus

To promote safe biking, a new [bicycle safety repair stand](#) opened on campus at the intersection of Galvez Mall and Escondido Road—along a busy commuting route. The bike safety repair stand offers free tools to enable bicyclists to make minor repairs and pump up their tires, making it more convenient for the campus community to keep bicycles in good working condition. Multiple tools are securely fastened to the rack, which also serves as a bike stand. As a result of its success, a second repair stand location is planned for the high traffic area near the School of Medicine.



**More Information:**

[http://transportation.stanford.edu/alt\\_transportation/BikingAtStanford.shtml](http://transportation.stanford.edu/alt_transportation/BikingAtStanford.shtml)

**Goal: Enabling Energy Savings and Carbon Reduction**

**Stanford:** IT energy usage depends on application

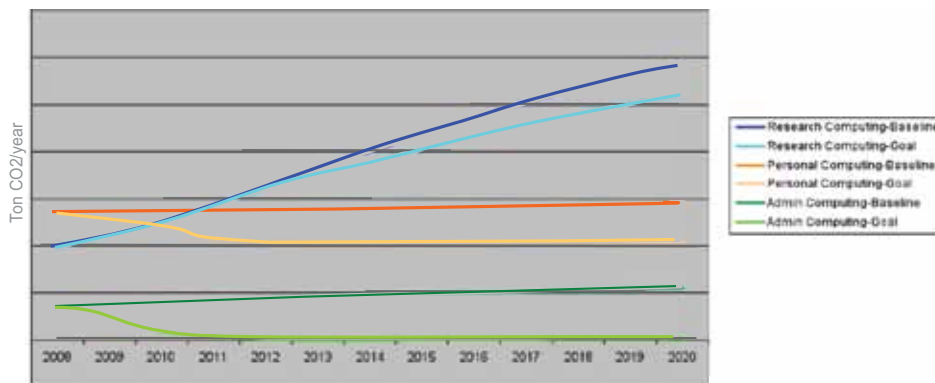

**Challenge:** Finding a solution for Research Computing





## Students Embrace International Day of Climate Action

Stanford students came together on October 24th to advocate and show support for strong climate change action at December's Copenhagen Climate Conference. The event, a group game of Frisbee on the Oval, was part of the [International Day of Climate Action](#), urging global leaders to stabilize atmospheric carbon at 350 parts per million. Photographs taken from the day's events were compiled with those from other communities throughout the globe and sent to UN delegates and state leaders with the goal of impacting December's conference. Student groups collaborated to organize the gathering and are planning a larger event for the 2010 International Day of Climate Action.



### More Information:

<http://www.350.org/>



## Climate-Conscious Food Week Underscores Impact of Food Choices

In support of the [International Day of Climate Action](#), Stanford Dining hosted its first [Climate-Conscious Food Week](#) to educate Stanford students about the impact of food choices on the climate. Students were asked to participate in a different activity on each day of the week-long event, including dining without a tray and eating a vegetarian or vegan meal.



Over 30 student volunteers, representing several sustainability-focused student groups, played a hands-on role in educating their classmates about climate-friendly eating habits in the dining halls. More than 900 students participated in the event, making it one of Stanford Dining's most successful awareness campaigns to date. Stanford Dining will organize another weeklong sustainability-focused event in 2010 to build upon the Stanford Food Summit scheduled in early November.

### More Information:

<http://www.350.org/>

<http://www.stanford.edu/dept/rde/dining/awareness.htm>







## Green Living Council Launches Green Screens Series

Students gathered at 10 different locations across campus for the purpose of environmental education and fun. "Green Screens," an environmental documentary night put on by the [Green Living Council](#) (GLC), showed films ranging from Planet Earth to King Corn in dorms and houses throughout the night. GLC hoped the event would make environmental films more accessible to the average student. The film showings were followed by discussions that GLC members reported were both educational and engaging. The Green Screens event was one of many that GLC put on in the fall, as the organization, now in its third year, continued to grow and expand its presence on campus.

### More Information:

<http://glc.stanford.edu/>



## Aggressive Energy and Climate Plan Unveiled

Stanford developed an ambitious, long-range, \$250 million initiative to sharply reduce the university's energy consumption and greenhouse gas emissions. Changes outlined in the [Energy and Climate Plan](#) could reduce the campus carbon impact by as much as 20% below 1990 levels by 2020, and 50% below 1990 levels by 2050. While the initial phases of the plan rely on aggressive energy conservation and major changes to the campus heating and cooling scheme, more greenhouse gas reductions may be possible through the use of renewable electricity and other energy management technologies. The Energy and Climate Plan, presented to the Stanford Board of Trustees in October, is one of the most ambitious carbon-reduction programs of major U.S. universities. It includes higher-than-required energy standards for new buildings, major retrofitting of existing buildings, a significant transformation of the campus energy plant, and programs to teach students, faculty, and staff how to cut back on energy use. "At Stanford, we're taking steps to reduce greenhouse gases through improved efficiency both in consumption and generation of energy," said Stanford President John Hennessy. "Our goal is both to lower our energy costs and to lower our carbon emissions, which is the right step for Stanford and for our planet."

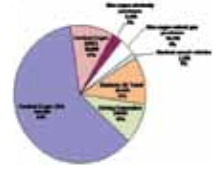

### More Information:

[http://sustainable.stanford.edu/climate\\_action](http://sustainable.stanford.edu/climate_action)





## 2009–2010 Student Green Fund Winners Announced

The [Student Green Fund](#) committee announced the 2009–2010 grant winners. Recipients were selected based on a project's potential to achieve the intended goals as well as its ability to enable active student participation in making a contribution to campus sustainability. Proposed topics included social behavior, renewable energy, real-time electricity data, and student gardening initiatives. The winning projects received close to \$30,000 in total funding and included:

- Campus Garden Initiative (CGI)
- Campus Outdoor Recycling
- Organic Fertilizer
- Row House Sustainable Foods Program
- Stanford Social Movement Challenge (SSMC)
- Sprig (plugVIEW)
- Solar Initiatives Site Resource Assessment (SWEP)
- Salinas Valley Wind Resource Assessment (SWEP)
- Water Catchment System

While some scopes and durations were extended, the majority of projects are complete. The committee is preparing for the 2010–2011 application and selection process.

### More Information:

[http://sustainable.stanford.edu/green\\_fund](http://sustainable.stanford.edu/green_fund)



## “Best Workplaces for Commuters” Title Repeated

Stanford University was once again nationally recognized as one of the “[Best Workplaces for Commuters](#)” for offering outstanding commuter benefits. Stanford offers both employees and students free East Bay transit service, offers employees free train and bus passes, provides vanpool subsidies, and offers all eligible commuters cash and other incentives for using alternative transportation instead of driving alone to campus.

The “Best Workplaces for Commuters” recognition program was first established in 2001 by the U.S. Environmental Protection Agency (EPA) and U.S. Department of Transportation (DOT) to promote innovative solutions to commuting challenges faced by employers and employees. Employers that meet the National Standard of Excellence in commuter benefits—a standard created by the National Center for Transit Research (NCTR) and the U.S. EPA—can apply for the “Best Workplaces for Commuters” title. Through partnerships with public-and private-sector employers, the program demonstrates that alternatives to drive-alone commuting, such as transit, carpools, and vanpools, are economically beneficial, yielding value to workers, employers, and the environment.

### More Information:

<http://transportation.stanford.edu/>

<http://www.bestworkplaces.org/>





## The New Business School En Route to LEED Platinum Rating

The new home for the Graduate School of Business, the [Knight Management Center](#), is nearing completion and remains on track for a LEED® Platinum certification. In November 2009, the school learned from the [U.S. Green Building Council](#) that 37 points—of the 52 needed for the Platinum ranking—from the team's initial submittal had been anticipated as approved. When construction concludes, the team will submit the remaining credits for approval. Among those achieved in the design submittal were credits related to energy performance and on-site renewable energy—each of which contributes to the complex's 45% reduction in energy consumption. In addition, the design team reduced potable water use by 80% compared to consumption in similar buildings. Construction will finish in spring 2011. The Knight Management Center will be the first LEED-certified project at Stanford.

### More Information:

<http://www.gsb.stanford.edu/knightcenter/>

<http://www.usgbc.org/>



## First Podcast Tour of Campus Plants, Animals, and Science Art

Stanford biologists Donald Kennedy and Paul Ehrlich, plant ecologist Katherine Preston, and writer and artist Darryl Wheye presented the first in a series of self-guided podcast tours featuring the biological heritage of the Stanford campus and its rich collection of outdoor art. The first route, a tour of [Plants, Animals, and Science Art](#), narrated by Donald Kennedy, leads listeners from Canfield Court past the Bing Wing of Green Library into the Main Quad. It includes five works from the Stanford outdoor art collection, viewed through the lens of science as examples of Science Art. The one-hour audio tour calls attention to sustainability in the broadest sense, encompassing both the ecology of campus plants and animals and the essential role of the creative process in human lives, reminding the community of its place in nature and its responsibility to understand nature's limits. The podcast was funded in part by a grant from the Stanford Institute for Creativity and the Arts.

### More Information:

<http://bgm.stanford.edu/groups/grounds/points>





## Stanford Wins “Race to Excellence” Awards from Best Workplaces for Commuters

[Best Workplaces for Commuters](#), a program designed to encourage sustainable transportation innovation and managed by the University of South Florida’s National Center for Transit Research, singled out 27 companies, institutions, and individuals nationwide for 2009 Race to Excellence awards. Stanford received two awards:

- Best Employee Transportation Coordinator
- Gold Level Winner for its transportation demand management program

The awards recognize organizations that have taken exemplary steps to offer alternatives for their employees driving alone and thereby reduce air pollution, traffic congestion, and fuel consumption.

### More Information:

<http://www.bestworkplaces.org/>

<http://www.bestworkplaces.org/race-to-excellence-2/>



## Annual Winter Closure Saves Utility Charges

[Sustainability and Energy Management](#) and [Buildings and Grounds Maintenance](#) partnered to organize the annual Winter Closure. The goal of Stanford’s Winter Closure is to maximize energy savings and reduce operating expenses. While Stanford is an institution that can never completely shut down, coordination can increase conservation efforts. In 2009 the curtailment effort allowed Stanford to avoid almost \$134,000 in utility charges. The university shut down to the fullest extent possible starting at the close of business Friday, December 18, 2009, and reopened with the start of business on Monday, January 4, 2010. Planning and coordination of the shutdown with facilities managers located in each school and department enabled facilities staff to turn off heat and ventilation and cancel custodial services in areas where those services were deemed unnecessary. Normal electricity and domestic water service was made available at all times and an emergency plan to prevent freeze damage was created for implementation if necessary.



### More Information:

[http://sustainable.stanford.edu/energy\\_initiatives](http://sustainable.stanford.edu/energy_initiatives)





## Students Experience Climate Policy in Action at Copenhagen Conference

Over 50 Stanford students witnessed climate policy in action at the United Nations Framework [Convention on Climate Change](#) in Copenhagen, Denmark, last December. The students, accompanied by Stanford professors Stephen Schneider and Terry Root, received observer passes to the negotiations. The undergraduate and graduate participants prepared for the trip through a quarter-long class that outlined the roles of various stakeholders, including a group simulation of the talks. Meeting California's Governor Arnold Schwarzenegger was a favorite moment of the trip for many students, who returned to campus with unique knowledge about policy making and diplomacy. Some students felt frustrated by the negotiation process, finding it cumbersome and without a sense of urgency. This experience motivated many to take more direct action once back at Stanford.

### More Information:

[http://unfccc.int/meetings/cop\\_15/items/5257.php](http://unfccc.int/meetings/cop_15/items/5257.php)



## Office of Sustainability Partners with Woods Institute to Launch CEE/ES 109 Green Buildings & Behavior Course

The Office of Sustainability collaborated with the Woods Institute for the Environment to offer [Civil and Environmental Engineering / Earth Systems 109](#) in the winter quarter of the 2009–2010 academic year. The first overarching local sustainability course offered by Stanford, CEE/ES 109 aimed to engage students in employing sustainability within an institution, and featured more than 20 Stanford faculty and staff who lectured on topics that included energy efficiency, water use, waste management, sustainable food, and transportation systems. The final class project required students to complete [BLSP](#) audits and evaluations for two School of Earth Sciences buildings identified as prime program candidates. During the spring and summer, two class participants capitalized on the course's momentum and joined the Office of Sustainability as Student Sustainability Coordinators to help further deploy behavioral programs across campus. CEE/ES 109 is now an annual offering.

### More Information:

<http://sustainable.stanford.edu/students>

[http://sustainable.stanford.edu/buildings\\_initiative](http://sustainable.stanford.edu/buildings_initiative)





## President's Column Highlights Energy and Climate Plan

In the January/February 2010 issue of the Stanford Magazine, President Hennessy addressed the university's increasing commitment to sustainability and climate action in the President's Column titled *When Less is More*. The column focused on Stanford's *Energy and Climate Plan*, which will reconfigure building systems to transfer the heat discharged by the campus cooling system to buildings that need warming. The column also mentions the ongoing success of building retrofit programs, new building construction standards, "greening" events, and the important role of students, faculty, and staff in campus-wide sustainability implementation efforts.

### More Information:

<http://www.stanfordalumni.org/news/magazine/2010/janfeb/dept/prez.html>  
[http://sustainable.stanford.edu/climate\\_action](http://sustainable.stanford.edu/climate_action)



## Students Compete in Sixth Annual Conservation Cup

Formerly known as the Energy Bowl & Water Derby, the *Conservation Cup* is an annual competition put on by *Students for a Sustainable Stanford* and the *Green Living Council* with support from *Student Housing*. In its sixth year, the contest continued its tradition of pitting Stanford residences against each other in a battle to conserve the most water and electricity during winter quarter. By using less electricity and water than they used during the same time period last year, residences are eligible to win prizes and bragging rights. Most importantly, residents help promote sustainable behavior at Stanford through participation in the annual competition. In 2010 two houses, Hammarskjold and 717 Dolores, achieved combined energy and water reductions of over 20% from the previous year.

### More Information:

<http://glc.stanford.edu/conservationabout>  
<http://sustainability.stanford.edu/ccup2008/conservationcup.html>

**THE WINNERS**  
**of Stanford's 2010 Conservation Cup!**

**Greatest Reduction**  
 For achieving a reduction greater than 20%, the special award for **Hammarskjold** and **717 Dolores** is a House Ball Trip to the California Academy of Sciences. Every residence achieving a reduction greater than 10% receives a reusable water bottle.

**Most Efficient**  
 The more efficient your residence is to begin with, the harder it is to reduce your electricity and water use. That's why we are recognizing the following two residences with the annual Conservation Cup House to reward them for their ongoing efforts to conserve natural resources.

Residence	Average Efficiency	% Reduced (vs. previous year)
1. Hammarskjold	-25%	-25%
2. 717 Dolores	-20%	-20%
3. Mars	-18%	-18%
4. Hays MH	-17%	-17%
5. Jerg	-15%	-15%
6. Blue Don	-14%	-14%
7. Calabasas	-14%	-14%
8. 682 Larkin	-12%	-12%

**Most Efficient House (lowest cost)**  
 Mars: \$0.53

**Most Efficient Residence (vs. previous year)**  
 Sillit: \$0.57

**Thanks to all students for participating and helping conserve our resources!**

**The Green Living Council**  
 To learn more about how to live sustainably at Stanford, contact your residence's Green Living Coordinator. For more information about getting involved in the Green Living Council, visit: <http://sustainable.stanford.edu/greenlivingcouncil>.

For more information, visit: <http://livinggreen.stanford.edu>

**STUDENT HOUSING**  
 Stanford University

Student Housing is a Division of Residential & Dining Enterprises.





## Stanford Posts Strong Results in Annual RecycleMania Competition

For the fourth year in a row, Stanford entered [RecycleMania](#), a nationwide recycling contest to see which schools can recycle the most and landfill the least. Stanford achieved an all-time high 65% diversion rate in 2010, thanks in part to continued participation in RecycleMania. Stanford's waste reduction and recycling programs gain a prominent position in the campus dialogue during the competition. Lasting effects carry forward through the remainder of the academic year as RecycleMania reminds the campus community to keep up the momentum for waste reduction. In the RecycleMania 2010 contest, Stanford scored in the top 25 in six of the eight categories:

- per capita collection of recyclables (21st place)
- gorilla total tonnage (3rd place)
- paper recycling tonnage (11th place)
- cardboard recycling tonnage (20th place)
- bottles and cans recycling tonnage (23rd place)
- food waste recycling tonnage (6th place)

Preparations are under way for the 2011 competition with an increased emphasis on awareness of composting and other strategies to reduce overall campus-wide waste.

**More Information:**

<http://www.recyclemaniacs.org/Index.htm>



## Increased Operational Robustness in Department of Sustainability and Energy Management

The [Department of Sustainability and Energy Management](#) underwent further organizational definition with respect to both operational and behavioral programs. To further advance Stanford's building operations program, energy management programs and staff previously spread amongst three different divisions, Zone Management, Buildings and Grounds Maintenance, and Utilities, consolidated into a new division called Facilities Energy Management. With a singular focus on adeptly managing campus energy demand in buildings, this new group is led by a senior engineering director with expertise in building energy systems, operations, and retrofits. To further advance Stanford's behavioral conservation programs, the Office of Sustainability expanded to include a new coordinator responsible for building-level programs, related communications and training, and overall program evaluation, especially for the built environment.

**More Information:**

[http://sustainable.stanford.edu/program\\_staff](http://sustainable.stanford.edu/program_staff)

<http://sustainable.stanford.edu/energy>

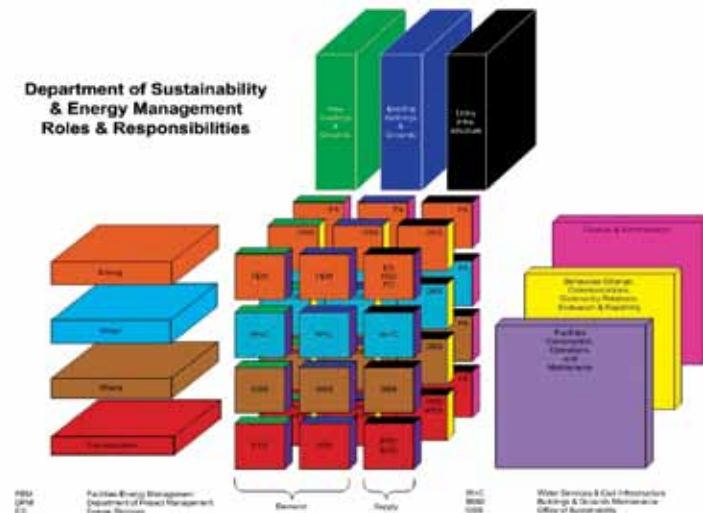



## Zero-Waste Program Launched: Three Dining Locations Pilot Effort

The ASSU Executive sustainability team, through collaboration with Students for a Sustainable Stanford (SSS) and Stanford Hospitality and Auxiliaries, piloted [zero-waste programs](#) at three campus dining locations. New compost bins were placed at Union Square in Tresidder, the Axe & Palm, and the new Russo Café in Munger. The compost bins were accompanied by recycling bins for glass, plastics, and paper, as well as signs to help diners sort waste into the appropriate receptacles. To support and ensure ongoing success of the program, SSS trained eight Student Compost Coordinators to perform bi-weekly compost audits, as well as station themselves near receptacle areas to provide on-site education and direction to diners. Plans are in place to expand the program to other campus eateries throughout the 2010–2011 academic year.



### More Information:

<http://www.stanford.edu/dept/rde/shaa/sustain.htm>  
<http://assu.stanford.edu/>



## Materials Salvage, Reuse and Building Infill Projects Continue

As campus buildings are redeveloped, renovated, or repaired, Stanford makes a great effort to evaluate materials for their reuse potential and to repurpose existing facilities, redevelop inefficiently used sites, or infill where feasible. With each project, users and maintenance groups survey materials for reuse opportunities and demolition contractors assess materials for salvage. Surplus Property may select items for resale as well. Recent examples of materials salvage, reuse, and sustainable land use include:

- ◉ Replacement of 149,000 GSF of low-rise construction with the 545,000-GSF high-performance Science and Engineering Quad
- ◉ Salvage of bricks, original sandstone, marble, and terra cotta roof tiles from recent demolitions at Encina Gym, the Serra Complex, Kresge Auditorium, and Wallenberg Hall
- ◉ Use of salvaged bricks and pavers in Crothers Hall, Panama Mall, and the Automotive Innovation Facility renovations and construction
- ◉ Replacement of 84,000 GSF of low-rise offices and extensive surface parking lots with the 360,000 GSF Knight Management Center
- ◉ Repurposing of a modular storage building on Oak Road to support field activities for the biology and cultural resource conservation programs

### More Information:

<http://lbre.stanford.edu/dpm/>  
<http://lbre.stanford.edu/luep/>







## Monitoring System Extends to New and Existing Buildings

Stanford's Supervisory Control and Data Acquisition (SCADA) system expands continually to include new buildings and existing campus users, with the [Huang Engineering Center](#), the [Center for Nanoscale Science and Engineering](#), the [Li Ka Shing Center for Learning and Knowledge](#), the Visitor Center, Braun Music Building, Peterson Lab, and Jordan Hall joining the portfolio this year. Smart-grid technology, including meters that provide detailed time-of-use profiles for customer loads and devices that monitor the status and health of the power distribution system, offers substantial energy management potential. In 2003, [Stanford Utilities](#) installed its first smart meters connected to the SCADA system for demand monitoring and system control. Today, the SCADA system allows remote real-time monitoring of the loads in most large campus buildings, along with long-term trending data. At the system level, the meters and protective devices allow engineers and technicians to quickly spot problems and restore service. The information obtained from the SCADA system enables sustainability staff to characterize buildings by electrical intensity and gage improvements made by demand-side modifications.

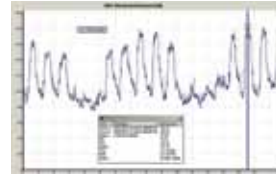

### More Information:

[http://lbre.stanford.edu/sem/high\\_voltage](http://lbre.stanford.edu/sem/high_voltage)



## Energy Secretary Steven Chu's Speech Inspires Energy Revolution

U.S. Secretary of Energy, and Professor Emeritus of Physics, Steven Chu delivered an inspiring and entertaining keynote speech entitled "Meeting the Energy and Climate Challenge" on March 8th, 2010. In front of the capacity crowd at the [GAIA](#)-hosted event, Chu urged Stanford and the nation "to lead the world in a new industrial revolution," a clean energy revolution. Chu explained his vision for a successful energy bill and reminded Stanford of its historical role in innovation. To stay ahead, Chu matter-of-factly explained, "we have to get moving." Access to the [complete lecture](#) is available online courtesy of Stanford News. Chu's speech kicked off a series of discussions on campus, including a follow-up panel hosted by [Energy Crossroads](#), "Educating the Energy Generation." Sponsored by the Office of Sustainability, the ASSU, the Woods Institute for the Environment, and various energy-focused student organizations, Secretary Chu's visit served as a preamble to the weeklong FutureFest celebration in April.

### More Information:

<http://gaia.stanford.edu/>

<http://news.stanford.edu/news/2010/march/steven-chu-lecture-030810.html>

<http://stanford.energycrossroads.org/>

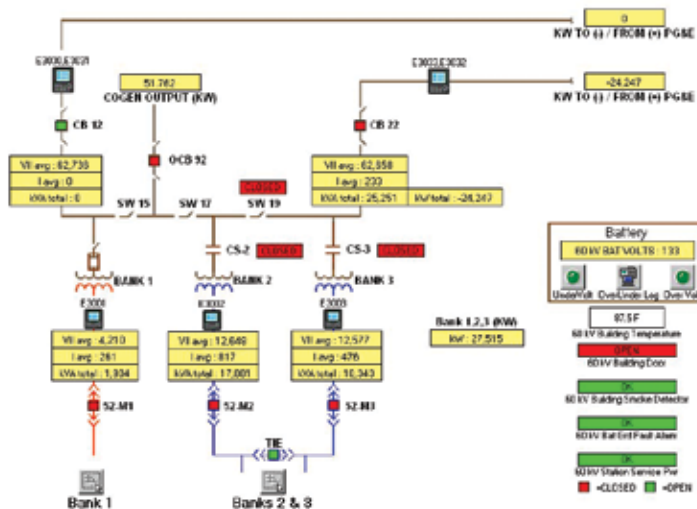



## Behavioral Training Provided at Annual Building Managers' Meeting

More than a third of Stanford's building managers responded to a survey targeting sustainable opportunities at the individual building level in early 2010. The Office of Sustainability teamed with Zone Management to compile the results and discovered several immediate training opportunities. Accordingly, representatives from the Water Conservation Program, Sustainable IT, and Food Systems facilitated a targeted panel presentation at the annual [Building Managers' Meeting](#). Speakers also publicized pilot results from the [Building Level Sustainability Program](#) to prepare building managers for program participation. During the coming year, the Office of Sustainability will extend training and information to school-level administrators.

### More Information:

[http://bgm.stanford.edu/bldg\\_mgr\\_mtg\\_presentations\\_2010](http://bgm.stanford.edu/bldg_mgr_mtg_presentations_2010)

[http://sustainable.stanford.edu/building\\_initiatives](http://sustainable.stanford.edu/building_initiatives)



## Li Ka Shing Center for Learning and Knowledge Project Complete

The [Li Ka Shing Center for Learning and Knowledge](#), a 118,000-GSF School of Medicine building, includes medical simulation and virtual reality environments to advance teaching, learning, and knowledge management. Four above-grade floors house a conference center, classrooms, and study areas. The basement features the Center for Immersive and Simulation-Based Learning. Prominent sustainability features include:

- ◉ Recycled water for flushing toilets and urinals
- ◉ High-performance glazing, sun shades, and a reflective roofing surface
- ◉ HVAC system with chilled beams and displacement ventilation
- ◉ Diversion of 95% of construction and demolition debris from landfill

The Li Ka Shing Center for Learning and Knowledge has already become a hub for education, training, conferences, and interdisciplinary programs for the School of Medicine.

### More Information:

[http://lbre.stanford.edu/dpm/Learning\\_and\\_knowledge](http://lbre.stanford.edu/dpm/Learning_and_knowledge)

<http://lksc.stanford.edu/>





## High-Efficiency Outdoor Lighting Piloted Across Campus

LED and induction lamp technologies improve the efficiency of conversion from electrical energy to light. LED technology uses solid-state light-emitting diodes to produce light at very high conversion efficiency, requiring a fraction of the electricity to create the same lighting level as a standard bulb.



Induction lamps are similar to fluorescent lights but use radio frequency induction to produce light. Both technologies have higher efficiencies, longer lifetimes, and better color rendering than traditional high-pressure sodium streetlights, making them attractive options for outdoor applications. LED streetlight pilot installations can be found on the west end of the Mayfield Avenue and Lomita Drive intersection and on Palm Drive near Arboretum Road, and pilot LED pathway lighting illuminates pedestrian access to the Bonair Siding buildings. Induction lights are currently being piloted in the Bonair facilities yard. Installed pilot lighting complies with the guidelines of the [International Dark-Sky Association](http://darksky.org), which promotes the reduction of light pollution. Experience gained from the pilots will allow Stanford to select the most beneficial technology for broader installation across campus.

### More Information:

[http://lbre.stanford.edu/sem/power\\_systems](http://lbre.stanford.edu/sem/power_systems)

<http://darksky.org>



## Habitat Conservation Plan Draft Released for Public Review

Stanford released the [Habitat Conservation Plan \(HCP\)](#) draft, along with a Draft Environmental Impact Statement (DEIS), for public review and comment. The plan is a product of more than 10 years of collaboration with the [U.S. Fish and Wildlife Service](#) and [NOAA Marine Fisheries](#) and is intended to provide a long-term, comprehensive conservation program for five species on Stanford land protected under the Endangered Species Act. A public comment meeting was held at Tresidder, and Stanford conducted outreach meetings for local agencies and communities over the summer. The public review period for the HCP and DEIS concluded in August and federal agencies are expected to approve the HCP in December 2010.

Ponds constructed to mitigate loss of wetlands associated with construction and maintenance projects have been in operation for three years. Their hydrology is performing as designed, and functioning biological communities have developed, supporting aquatic plants, birds, and aquatic invertebrates. To provide additional California tiger salamander breeding opportunities in the foothills, Stanford constructed eight ponds near the Gerona gate in 2001. Annual monitoring has documented that seven of the ponds provide the necessary hydrology to support the desired biological communities and that successful salamander reproduction has occurred in three of the ponds.

### More Information:

<http://hcp.stanford.edu/>





## Research: Electric and Fuel Cell Vehicle Showcase Highlights Race for Sustainable Automobiles

To the delight of car enthusiasts, Stanford University played host to a [showcase for alternative fuel vehicles](#). For five hours, students heard from manufacturers of cars powered by electricity and hydrogen fuel cells. Manufacturers discussed some of the problems inherent to the different technologies as well as the inherent difficulties of updating infrastructures to support the new technologies. Ultimately, they said, it will be the consumer that decides which technology is destined to replace gasoline-powered cars. The event was sponsored by the [Woods Institute for the Environment](#) and the [Precourt Institute for Energy](#) and featured representatives from major automobile companies, including Tesla, Honda, and Toyota.

### More Information:

<http://woods.stanford.edu>

<http://pie.stanford.edu/>

<http://news.stanford.edu/news/2010/april/electric-car-showcase-040910.html>



## Student Initiative to Include Sustainability in Curriculum Considered by Faculty Senate Subcommittee

Members of [Students for a Sustainable Stanford](#) developed a proposal that calls for the addition of "Sustainable Citizenship" to the four areas of study that satisfy the "Education for Citizenship" general education requirement. The [Committee on Undergraduate Standards and Policies](#) met to discuss the student proposal and considered it as an agenda item for a future full Faculty Senate meeting. The Association for Advancement of Sustainability in Higher Education (AASHE) Weekly Bulletin highlighted the student efforts to formalize sustainability in Stanford's curriculum. Over the summer the initiative merged with the concurrent Study of Undergraduate Education at Stanford process. Students intimately involved with the original proposal were invited to join the subcommittee on the "Education for Citizenship" requirement, where they plan to advocate for the formalization of sustainability in Stanford's curriculum throughout the 2010 fall quarter.

### More Information:

<http://www2.aashe.org/archives/2010/0419.php#16>





## FutureFest Celebrates Earth Week

**FutureFest**, an all-day festival conclusion to “An Art Affair,” moved students toward collective action regarding the interconnected challenges that threaten their future. The festival featured a progressive green economy rally led by Van Jones, a sustainable fashion show, student performers from the Stanford Soundtrack, and headlining artist De La Soul. Interactive booths focusing on food, water, energy, and waste educated festivalgoers about the connections of these topics to various social and economic issues and showcased academic and extracurricular opportunities on campus. FutureFest rallied support from hundreds of students and represented an important step from the student body towards a more interdisciplinary approach to the fundamental principles that form the student body’s vision of the future, at Stanford and in the world. The event was made possible by the collaborative efforts of campus sustainability groups under the [Green Alliance for Innovative Action](#) coalition, the Student Organizing Committee for the Arts, the Stanford Concert Network, and the Office of Sustainability.

### More Information:

<http://www.wix.com/milelire/futurefest2010>

<http://gaia.stanford.edu/>



## Two Campus Locations Win Clean Bay Business Award

The [City of Palo Alto Regional Water Quality Control Plant](#) (RWQCP) recognized the Stanford Golf Course Maintenance Shop and the Fleet Garage and Service Station as “[Clean Bay Businesses](#)” designation for the tenth consecutive year. Both locations were commended for their efforts to keep pollutants out of local creeks and San Francisco Bay by using eco-friendly practices in the workplace. Routine visits by the City of Palo Alto and compliance with the Sewer Use Ordinance assured the Golf Course Maintenance Shop and the Fleet Garage recognition as Clean Bay Businesses.



The Clean Bay Business program was started in 1992 to meet stricter effluent limits imposed on the RWQCP by the California Regional Water Quality Control Board for discharge into the San Francisco Bay. The RWQCP targets specific businesses, such as vehicle facilities, to reduce their pollutant load. The metal load to the plant was reduced through increased regulation, education, and positive incentives to those facilities that comply with the local ordinance.

### More Information:

<http://www.cleanbay.org/>





## Stanford Included in the USGBC and Princeton Review Guide to 286 Green Colleges

Stanford is included in the Princeton Review's first-ever [Guide to 286 Green Colleges](#), produced in partnership with the U.S. Green Building Council (USGBC) and released on Earth Day 2010. The Energy and Climate Plan, the Student's Guide to Sustainable Living at Stanford, and the CEE/ES 109 Green Buildings & Behavior course were a few of the new items Stanford highlighted in this year's survey response. The Princeton Review specifically praises Stanford's transportation demand management program and building-level behavior-based conservation programs in the half-page profile. The Guide to 286 Green Colleges is free and available to the public.



### More Information:

<http://www.princetonreview.com/green-guide.aspx>

<http://sustainable.stanford.edu/>



## Greening Events at Stanford Guidebook Published

Implementing green practices at large campus events, such as conferences and ceremonies, as well as small events, such as meetings and dinners, demonstrates a pervasive commitment to sustainability. Published in April, Stanford's [Greening Events at Stanford](#) booklet helps groups plan and execute more environmentally sustainable events. Sections provide education on food choices and catering, zero waste, communication, transportation, and post-event considerations specific to Stanford. A master checklist provides a comprehensive resource for all event organizers. Major campus celebrations, such as Commencement, New Student Orientation, and Reunion Homecoming have already incorporated recommendations from the guidelines into event planning and execution.

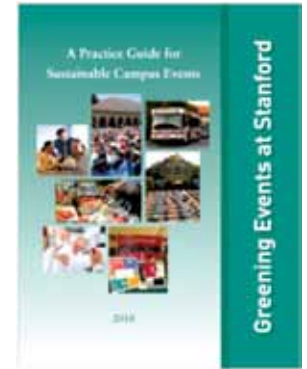

### More Information:

<http://sustainable.stanford.edu/events>





## Graduate School of Business Celebrates Earth Day with Low Carbon Diet Day

Every year, the Graduate School of Business (GSB) celebrates [Low Carbon Diet Day](http://www.eatlowcarbon.org/) in conjunction with its food service provider, Bon Appétit Management Company. The food system is responsible for a third of harmful greenhouse gas emissions, so the GSB and its vendors work together to make food choices that decrease impact on global climate change. This year, Low Carbon Diet Day took place on Earth Day, April 22, 2010. The GSB café created a meal for all guests made entirely from sustainable, low-carbon foods. The day helped demonstrate the GSB's long-term vision: a low-carbon operation with less food waste, regional and seasonal produce, reduced quantities of beef and cheese, no air-freighted fish or fruit, and house-made alternatives to energy-intensive processed foods. In partnership with Bon Appétit, the GSB aims to reduce emissions from its food by 25% in just five years.

### More Information:

<http://www.eatlowcarbon.org/>

<http://www.cafebonappetit.com/stanfordgs>



## Climate Change Featured as Central Theme of Annual Walk the Farm Tour

The [Bill Lane Center for the American West](http://www.stanford.edu/billlane) selected climate change as this year's theme for [Walk the Farm](http://www.stanford.edu/walkthefarm), an annual 21-mile hike through Stanford lands. Participants spent 12 hours trekking a course that started and ended at Y2E2, wound its way to Jasper Ridge Biological Preserve by way of the Dish, Felt Lake, and Web Ranch, and returned to campus via the Stanford Linear Accelerator, Sand Hill Road, and Campus Drive Loop. The group stopped at regular intervals to hear presentations describing the effects of climate change on Stanford lands as well as the university's response. The Office of Sustainability summarized the 2009 Energy and Climate Plan at the cogeneration facility and highlighted high-performance building design at the Knight Management Center construction site. Other representatives from the Department of Sustainability and Energy Management discussed the potential impact of climate change on Stanford's water supply and requirements.



### More Information:

<http://news.stanford.edu/news/2010/may/walk-the-farm-050310.html>

<http://west.stanford.edu/>

[http://sustainable.stanford.edu/climate\\_action](http://sustainable.stanford.edu/climate_action)





## Research: Electrode with Implications for Solar Photovoltaic Technology Earns C3Nano MIT Clean Energy Prize

Congratulations to Stanford's C3Nano for winning the MIT Clean Energy Prize and a \$200,000 grant! A start-up led by doctoral students Ajay Virkar and Melbs LeMieux and chemical engineering professor Zhenan Bao, C3Nano designed an electrode that will both increase the efficiency and reduce the cost of thin-film solar photovoltaic panels. Crossover applications with the electronics industry make the team's technology potentially even more attractive. For more details, please see the [press release](#) from the MIT News Office and C3Nano's [coverage](#) in the Stanford Daily.

### More Information:

<http://web.mit.edu/press/2010/clean-energy-prize.html>



## Record Ridership on Bike to Work Day

Stanford saw record-breaking participation in [Bike to Work Day](#), with more than 1,400 bicyclists stopping by one of nine Energizer Stations at the university, Stanford Hospital and Clinics, and SLAC National Accelerator Laboratory—a 50% increase in participation compared to 2009. The commutes recorded at all nine Stanford Energizer Stations represent 2,039 miles not driven, resulting in an estimated one-ton reduction of carbon dioxide emissions in one day. Bike commuters received tote bags and breakfast refreshments at each Energizer Station, and all riders were encouraged to sign Stanford's [Bike Safety Pledge](#). Leading up to Bike to Work Day, Stanford launched a "spring into a new commute" outreach campaign, which encouraged bicycle commuting—the most sustainable commute mode—by offering an array of bike promotions and resources.



### More Information:

<http://transportation.stanford.edu/btwd2010/>  
<http://transportation.stanford.edu/bikesafetypledge/>  
<http://transportation.stanford.edu/springcommute/>







## Research: Tracing the Source of Coastal Pollution in Hawaii

Pollution from a variety of human activities is threatening Hawaii's coral reefs. Alexandria Boehm, the Clare Booth Luce Assistant Professor of Civil and Environmental Engineering, was awarded an Environmental Venture Project grant from Stanford's Woods Institute for the Environment to investigate [the relationships among land use, groundwater quality, surface water quality, and coral reef health](#). The study focuses on two common coastal pollutants—fecal bacteria and nutrients. Researchers found that fertilizer runoff from a golf course was polluting groundwater flowing into the ocean in Kona, Hawaii. On Kauai, research revealed that streams, rather than groundwater, were the main conduits of pollution from agriculture. Boehm shared her results with local officials, which will enable them to develop strategies for improving coastal water quality.



### More Information:

<http://woods.stanford.edu/cgi-bin/focal.php?name=kona>



## Behavioral Sustainability Program Pilot Expands to the School of Earth Sciences

After successful building pilots in 2009, [BLSP](#) rollout advanced to the school level, specifically Mitchell and Braun within the [School of Earth Sciences](#). The Office of Sustainability welcomed two student sustainability coordinators who performed audits and worked closely with the building managers and occupants to craft a targeted green action menu for the School of Earth Sciences buildings. Preparation for conservation measures throughout the summer included significant delamping in common spaces, deployment of SmartStrips in private offices, installation of timers on shared printers, rollout of [desktop power management software](#) on all school-owned machines, and establishment of a composting program. Full implementation will begin in the 2010 fall quarter.

### More Information:

[http://sustainable.stanford.edu/buildings\\_initiatives](http://sustainable.stanford.edu/buildings_initiatives)





## University Employee Drive-Along Rate Drops to 48%

The employee drive-alone rate dropped from 72% in 2002 to 48% in 2010. If all university commuters, both employees and students, are counted, the drive-alone rate drops even lower to 43%. Reaching the point, where more than half of the university's commuting employees choose alternative transportation instead of driving alone, is a major milestone for Stanford. The reduction in drive-alone commutes demonstrates a high level of commitment both from the university and from commuters. It is even more significant in the context of the 78% drive-alone rate in the County of Santa Clara.

Stanford has invested in a [number of programs to encourage alternative transportation](#) over the past eight years, including free transit passes for eligible employees; vanpool subsidies of \$200 per month; and the Commute Club, whose eligible members receive up to \$282 per year for not driving alone to Stanford, up to \$96 in Zipcar driving credit, and free hourly rental car vouchers, among other incentives. The increased use of alternative transportation is credited to Stanford commuters, who are committed to improving health, protecting the environment, and increasing savings.

### More Information:

<http://transportation.stanford.edu/>

[http://transportation.stanford.edu/alt\\_transportation/](http://transportation.stanford.edu/alt_transportation/)



## Stanford Leads Stand Against Conflict Minerals: Board of Trustees Adopts Proxy Voting Guideline

Following a successful student campaign organized by [Stanford STAND: A Student Coalition to End and Prevent Genocide and Mass-Atrocities](#), the Stanford University Board of Trustees approved adoption of a new proxy voting guideline to address "conflict minerals" used frequently in the technology industry. In the Democratic Republic of Congo, armed groups force villagers to mine minerals like wolframite and cassiterite. Metals processed from these minerals are used in consumer electronics products like laptop computers and cell phones. Upon unanimous recommendation from Stanford's Advisory Panel on Investment Responsibility and Licensing and subsequent support from the Special Committee on Investment Responsibility, the Board approved the guideline, which states the university will "vote in favor of well-written and reasonable shareholder resolutions that ask companies for reports on their policies and efforts regarding their avoidance of conflict minerals and conflict mineral derivatives." Stanford is the first major institution to formalize concerns surrounding conflict minerals in its investment policies, and the successful Stanford student efforts received national coverage in a New York Times [article](#).

### More Information:

<http://stand.stanford.edu/>

<http://www.nytimes.com/2010/06/13/us/13bcminerals.html>





## SEQ Opens to Pedestrian Traffic

The buzz created by the opening of the Science and Engineering Quad (SEQ) to pedestrian traffic has been anything but quiet. Stanford University received the [Society for College and University Planning \(SCUP\) Merit Award](#) for SEQ with Boora Architects in the Planning for a District or Campus Component category. An outdoor space identical in size to the Main Quad, SEQ adapts the aesthetic vernacular of Stanford's most historic space to the modern era. A fourth building will formally complete SEQ in 2012, but the [Huang Engineering Center \(HEC\)](#) and the [Center for Nanoscale Science and Engineering \(Nano\)](#) recently received certificates of occupancy.

Building on the success of their predecessor, Y2E2, both HEC and Nano epitomize high-performance design and construction. Performance models suggest aggregate energy use in HEC and Nano, including plug loads, will be 42% and 37% less, respectively, than in standard buildings. Both buildings, use daylighting and photocell technology, employ a combination of natural ventilation and active chilled beams, and use the university's recycled-water system to flush toilets and urinals. In the HEC auditorium, 316 seats were salvaged from the demolition of Kresge Auditorium, refurbished, and redeployed. Each building will have a 30kW DC solar photovoltaic installation complete operation by the end of 2010.

### More Information:

[http://lbre.stanford.edu/dpm/nano\\_technology\\_center](http://lbre.stanford.edu/dpm/nano_technology_center)  
[http://lbre.stanford.edu/dpm/huang\\_school\\_engineering](http://lbre.stanford.edu/dpm/huang_school_engineering)



## Materials Conservation Project Under Way at Historic Hanna House

As part of Stanford's cultural resource conservation efforts, the [Land, Buildings and Real Estate](#) departments of [Land Use and Environmental Planning](#) and [Heritage Services](#) partnered to address the university's historic [Hanna House](#). Designed in 1936 by Frank Lloyd Wright for Stanford professor Paul Hanna, the house was temporarily closed for the summer to facilitate materials conservation projects. A team of seven student interns worked to clean all the interior and exterior brick and concrete surfaces, restore degraded redwood windows and doors, and document all the collections stored at the house. Initial phases of a garden restoration project also began, including repairs to original built-in planters. The house will reopen for tours and events in October 2010.



### More Information:

<http://hannahouse.tours.stanford.edu/>  
[http://lbre.stanford.edu/architect/historic\\_preservation](http://lbre.stanford.edu/architect/historic_preservation)





## Woods Institute Announces Four New Grants

The Woods Institute for the Environment awarded grants totaling \$787,013 to four interdisciplinary Stanford faculty teams working to promote global sustainability. The latest awards raise the [Environmental Venture Project \(EVP\)](#) grant total to \$5.4 million since its inception in 2004. [Stanford News coverage](#) profiled the 2010 EVP grant recipients and their projects:

- The Effects of Wildlife Loss and Land Use Change on Rodent-Borne Disease Risk in East Africa
- Rethinking the Balance between Future Obesity and Malnutrition with Climate Change
- Can Better Management Raise Growth and Reduce Pollution?
- Understanding the Carbon Cycle in Terrestrial and Marine Ecosystems with Field-Based Measurements Using a Revolutionary Isotopic Technique

### More Information:

<http://woods.stanford.edu/>

<http://woods.stanford.edu/evp>

<http://news.stanford.edu/news/2010/june/woods-evp-grants-062210.html>



## “Ditch that Dumpster” Event Prominent Feature of Green Move-Out

Students for a Sustainable Stanford, in collaboration with Stanford Student Enterprises and the ASSU Executive, sponsored “Ditch that Dumpster,” a campaign for green move-out targeting students vacating dorms for summer. Student volunteers collected reusable items such as clothing, futons, and electronics at dumpster locations and subsequently transported them to storage. At the beginning of fall quarter the group will resell the items to incoming students. The event allowed students to give back and identify a sustainable use for unwanted items, and it also provided an exciting opportunity to spread the message of waste reduction to the wider Stanford community.



### More Information:

<http://assu.stanford.edu/>

<http://recycling.stanford.edu/>





## Sustainable Stanford Presents at Silicon Valley Energy Summit

The Office of Sustainability joined with Sustainability and Energy Management colleagues to present “Energy Efficiency for End-Users: Tools and Techniques,” using the award-winning Environment and Energy Building (Y2E2) as a case study, at the 2010 Silicon Valley Energy Summit. The sold-out event, co-sponsored by the [Silicon Valley Leadership Group](#) and the [Precourt Institute for Energy](#), brings together industry professionals, academic researchers, venture capitalists, and policy-makers to discuss the latest energy-related technologies and strategies. Stanford’s presentation discussed Y2E2’s unparalleled academic collaboration and direct feedback to inform the next generation of high-performance buildings. Y2E2 has met and exceeded its water and energy conservation targets (it currently uses 42% less energy than code and 90% less potable water than equivalent structures). The presentation detailed successful design strategies and the challenges of predicting occupant behavior, and reviewed subsequent campus construction inspired by Y2E2.

### More Information:

<http://svlg.org/>

<http://pie.stanford.edu/index.html>

SILICON VALLEY  
ENERGY SUMMIT

June 25, 2010 | Stanford University



## Research: The Impact of Fishing on Coral Reefs

Fiorenza Micheli, professor of biology, believes that even light fishing pressure on coral reefs can have a significant impact on the health of reefs. Micheli and a team of Stanford researchers took advantage of an ongoing “natural experiment” at two isolated Pacific atolls, Palmyra and Tabuaeran, to gain new insights on the [ecology of reef fishing](#). Palmyra Atoll is a protected wildlife refuge, while Tabuaeran is home to about 2,500 people who depend on the reef for food and income. Micheli and the other researchers found that even the light fishing of 2,500 people led to significantly different fish levels between the two atolls. This research, funded by an Environmental Venture Projects grant from the Woods Institute for the Environment, contributes to the ongoing efforts to better understand sustainable fishing and coral reef protection.

### More Information:

<http://woods.stanford.edu/cgi-bin/focal.php?name=atoll>





## Open Letter Calls Attention to Fair Third-Party Sustainability Evaluations

Stanford's Office of Sustainability signed an [Open Letter to Sustainability Evaluating Organizations](#) outlining eight principles that define responsible rating programs, including transparency, consistent metrics, and flexible reporting. More than 30 colleges and universities have signed the letter with the hope that various evaluating organizations will raise their standards and improve the overall strength of rating systems. Detailed coverage is provided in the [Chronicle of Higher Education](#) and a discussion forum on the Association for Advancement of Sustainability in Higher Education website. As a result of the letter, the evaluating organizations are working towards a more robust scheme of metrics that treat major research institutions fairly.

### More Information:

<http://www.aashe.org/forums/>

<http://chronicle.com/article/Colleges-Say-They-Expect-Their/123617/>



## Stanford's Housing Stock Facilitates Local Compliance with AB 375

In an effort to reduce the carbon footprint throughout the State of California, the state adopted [AB 375](#), which mandates balanced regional land use planning in an effort to link jobs, housing, and transportation, thus reducing commuting and associated greenhouse gas production. Stanford contributes substantially to the regional housing stock and thus aids compliance with AB 375. A principle of contemporary city and regional planning is to provide an appropriate mix of housing, retail services, community services, and jobs in close proximity (i.e., compact development), which yields environmental benefits. The state mandates that regional planning agencies distribute a Regional Housing Needs Allocation (RHNA) to every county or city entity in the state. Each jurisdiction is required to produce a Housing Element that identifies sites where the RHNA could be addressed. Santa Clara County's Board of Supervisors approved the county's Housing Element in summer 2010. Of the 1,090 RHNA housing units assigned to Santa Clara County, 645 sites are identified at Stanford. The City of Palo Alto is currently in the process of completing its Housing Element, which must identify sites for its RHNA of 2,860 units.

### More Information:

<http://gov.ca.gov/fact-sheet/10707/>

<http://lbre.stanford.edu/luep/LUEP>





## Forsythe Data Center Earns Rebate Check for Sustainable IT Efficiency Measures

Stanford received a \$36,428 rebate check from PG&E for energy efficiency improvements in the Forsythe Data Center. Under the direction of the [Sustainable IT](#) program, the project included installation of a data center-wide environmental sensor network to track temperature, pressure, and humidity at each rack. Managers can log into the dashboard and review a visual display of conditions within the space. Alarms notify the team if sensors detect conditions outside the acceptable range. Existing computer room air handlers received variable-speed drives to facilitate greater precision in temperature management, and the existing outside air economizer was reconnected to directly supply cool air whenever the weather allows. Additional modifications included floor and ceiling tile replacement to better direct and contain air within the data center. Compared to operations a year ago, Forsythe houses an additional 17% of IT load but requires only 10% more electricity and 8% less chilled water. According to PG&E, the implemented efficiency measures save 359,000 kWh of electricity annually, equal to approximately 147 tons of avoided greenhouse gas emissions. Data center efficiency is an ongoing campus-wide Sustainable IT program.

**More Information:**

[http://sustainable.stanford.edu/sustainable\\_it](http://sustainable.stanford.edu/sustainable_it)



## Stauffer Chemistry Building Project Wins 2010 ASHRAE Technology Award Honorable Mention

The laboratory variable air volume (VAV) conversion in the Stauffer Chemistry Building won the 2010 Honorable Mention [ASHRAE Technology Award](#) in the Existing Institutional Building category. The award recognizes outstanding achievement in the design and operation of energy-efficient buildings, specifically the outstanding results of Stanford's [Whole Building Retrofit Program](#) in Stauffer. The many modifications included replacing pneumatic zone controls with direct digital controls, converting constant volume zones to variable volume zones, and adding occupancy sensors at each fume hood to control face velocity, and saved more than \$228,000 in FY2009. [ASHRAE Journal](#) featured the project in its September 2010 issue.

**More Information:**

<http://www.ashrae.org/members/page/1646>

<http://www.ashrae.org/publications/page/540>

[http://sustainable.stanford.edu/energy\\_initiatives](http://sustainable.stanford.edu/energy_initiatives)

Relative Monthly Energy Use

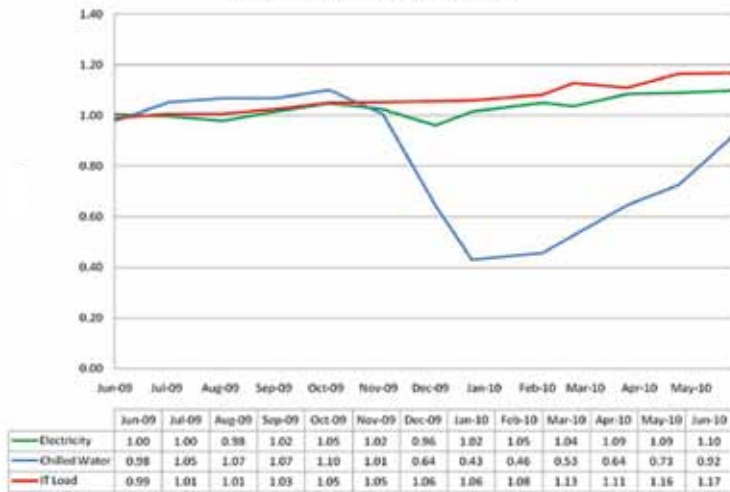



## Progress Continues with Central Plant Optimization Project as Part of 2009 Energy and Climate Plan

Proceeding with implementation of the [Energy and Climate Plan](#), Stanford has made significant progress with the necessary changes to the Central Energy Plant and the conversion from a campus steam distribution system to a hot-water system with heat recovery. American and European engineering firms with expertise in heat recovery technology and steam to hot water conversions have been hired, and the team has completed a 50% detailed conceptual design of the new regeneration system. Stanford has completed a full inventory of campus building HVAC systems and compiled a list of necessary changes for the heat recovery conversion at the building level. Stanford has also developed an in-house advanced computerized central energy facility energy modeling program to support design of the new heat recovery plant and its subsequent operation in the most economic and energy-efficient manner possible, significantly minimizing impact to the electrical grid. The team installed and tested a ground source heat exchange (GSHE) well and prepared an engineering analysis of the GSHE potential on campus for possible inclusion in the new heat recovery scheme. An engineering analysis of the Stanford Linear Accelerator (LINAC) heat rejection load pattern for possible inclusion of the major heat source into the heat recovery scheme has also been considered.

### More Information:

[http://sustainable.stanford.edu/climate\\_action](http://sustainable.stanford.edu/climate_action)

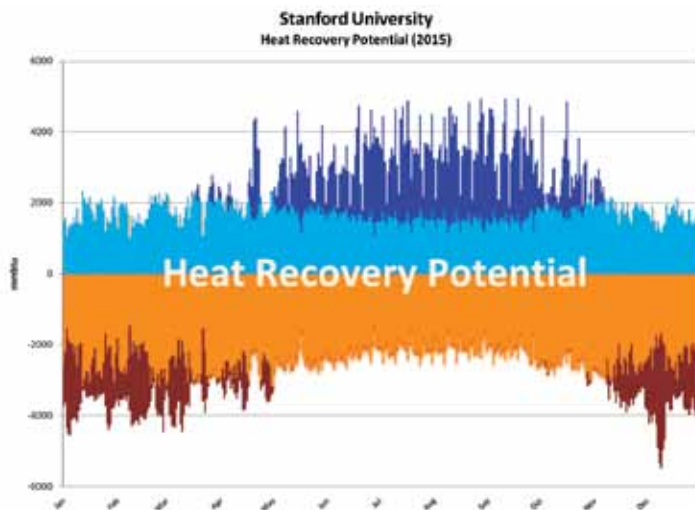

## Research: Sustainable Sewage Treatment

Two Stanford engineers, with support from a Woods Institute Environmental Venture Projects grant, are developing a [new sewage treatment process](#) that would actually increase the production of two greenhouse gases—nitrous oxide and methane—but use the gases to power the treatment plant. Craig Criddle, an expert in wastewater management, joined forces with Brian Cantwell, a professor of aeronautics and astronautics, to design the wastewater treatment system, which will run at a significantly lower cost and will also be essentially emissions-free. In the long term, Criddle hopes this technology will help restore balance to the world's nitrogen cycles, which have been disrupted by anthropogenic overuse of fertilizers.

### More Information:

<http://woods.stanford.edu/cgi-bin/focal.php?name=sewage>

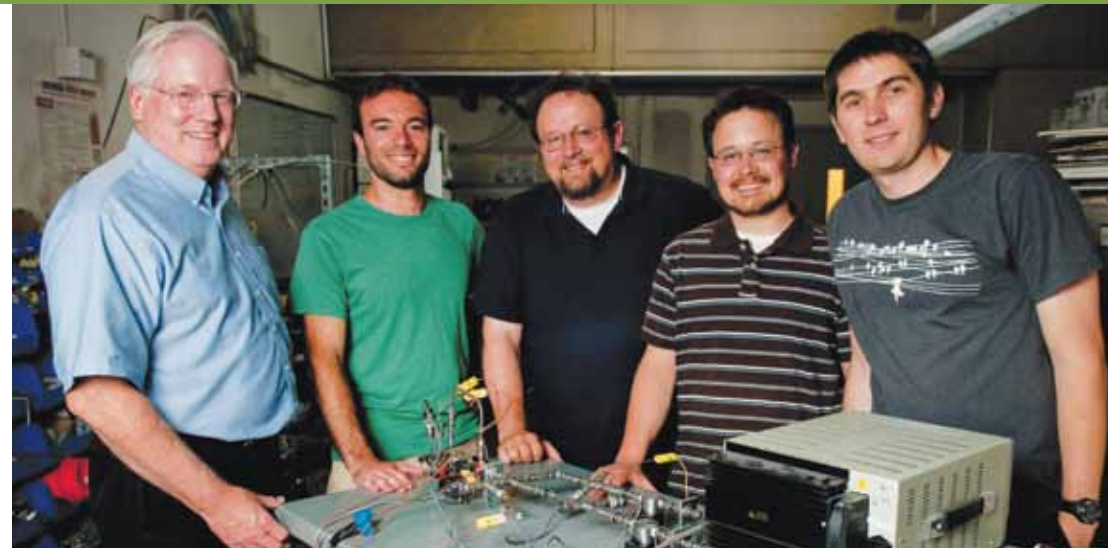





## Lorry I. Lokey Stem Cell Research Building Complete: Laboratory Fit-Up Begins

The [Lorry I. Lokey Stem Cell Research Building](#) (SIM1), a 200,000-GSF School of Medicine building, has a basement vivarium and three above-grade floors with research labs and support facilities. Stanford established targets comparable to a LEED Silver rating for the project. Significant sustainability features include:

- ◉ Segregated laboratory and other occupancy types to increase HVAC operating efficiency
- ◉ Sloped ceilings in labs for increased daylighting and solar photo cells for lighting control
- ◉ Reusable animal cages throughout the vivarium, eliminating cage wash equipment and avoiding the use of approximately 9 million gallons of water annually
- ◉ Elimination of relative humidity controls from air-handling equipment and the vivarium rooms due to the local climate

Scheduled to be fully occupied in the fall quarter of 2010 SIM1 is the nation's largest center dedicated to stem cell research. An example of high-performance building in the face of highly technical programmatic requirements, SIM1 serves as a national model for laboratory design and construction.

### More Information:

<http://lokey.stanford.edu/building/sustainability.html>



## Stanford Competes in the Great Race for Clean Air

On-road traffic accounts for approximately 40% of greenhouse gas emissions in the Bay Area, according to the [Bay Area Air Quality Management District](#) (BAAQMD). Stanford joined with Bay Area employers to help reduce these emissions by reducing drive-alone commutes during the [Great Race for Clean Air](#). All employees who log their sustainable commutes online will be entered into weekly drawings for prizes, such as gift cards from Starbucks and Best Buy, courtesy of the BAAQMD and 511. At the end of the competition, employers with the highest carbon dioxide savings and the highest employee participation are declared winners. With more than twice as many registered racers as any other Bay Area employer, and currently ranked third in total carbon dioxide emissions savings, Stanford expects a strong performance when the competition concludes and final results are tabulated.

### More Information:

<http://www.greatraceforcleanair.com/>

<http://sustainable.stanford.edu/transportation>

<http://transportation.stanford.edu/>





## Stanford Ranks Fifth in Sierra Magazine Sustainability Survey

Sierra Magazine released the [2010 Cool Schools sustainability rating](#), and Stanford ranked 5th out of 162 schools surveyed. This represents an excellent overall improvement from last year, when Stanford ranked 26th out of 135 schools. Stanford earned perfect scores in the Waste, Investment, and Other Initiatives categories, and performed strongly in the Academics, Transportation, Purchasing, and Administration categories. Accomplishments highlighted in this year's survey included the release of Stanford's [Energy and Climate Plan](#) as well as the CEE/ES 109 Green Buildings & Behavior course.



### More Information:

[http://www.sierraclub.org/sierra/201009/cool\\_schools/top100.aspx](http://www.sierraclub.org/sierra/201009/cool_schools/top100.aspx)

[http://www.sierraclub.org/sierra/201009/cool\\_schools/allrankings.aspx](http://www.sierraclub.org/sierra/201009/cool_schools/allrankings.aspx)

[http://www.sierraclub.org/sierra/201009/cool\\_schools/fantasydraft.aspx](http://www.sierraclub.org/sierra/201009/cool_schools/fantasydraft.aspx)



## First Regional Heat Exchange Station Opens

A major infrastructural improvement outlined in the [Energy and Climate Plan](#) is the conversion of Stanford's existing steam piping to a hotwater distribution system. The first physical evidence of this transformation appeared in August at the end of Memorial Way. Nestled behind the Graduate School of Business South Building and Memorial Auditorium, the first regional heat exchange station stands ready for action. It will serve about a dozen nearby structures, including athletic facilities, the existing GSB buildings, and the new Knight Management Center. The station uses steam piped from the cogeneration plant to heat hot water and distributes that directly to buildings in the service area. The smaller, local heat exchangers in each building's mechanical room are being replaced with equipment suited for hot water, a procedure carefully designed to minimize impact to building occupants. The aggregate energy use in the service area should drop almost immediately upon system activation, demonstrating the advantage of such a conversion on a campus-wide scale. As implementation of the Energy and Climate Plan progresses, a network of regional heat exchange stations will open across campus and building-level conversions will continue, ultimately setting the stage for transformation of the cogeneration plant to a "regeneration" facility with heat recovery.

### More Information:

[http://sustainable.stanford.edu/climate\\_action](http://sustainable.stanford.edu/climate_action)





## Student's Guide to Sustainable Living at Stanford Updated and Sent to Incoming Class of 2014

The Office of Sustainability updated the popular booklet entitled "A Student's Guide to Sustainable Living at Stanford." An intern with the office and the lead author of the original guide spearheaded the updates, which represent a collaborative effort by students, faculty, and staff from many departments across Stanford's campus. It provides practical tips for how students can reduce their environmental impact, as well as giving information about Stanford's current sustainability efforts. The guide was sent electronically to the Class of 2014 as part of the Approaching Stanford materials. It is also available on the Sustainable Stanford website and will be showcased at the Residential Advisor training fair and the Parent's Resource Center during New Student Orientation.

### More Information:

<http://ual.stanford.edu/NBY/Freshman.html>

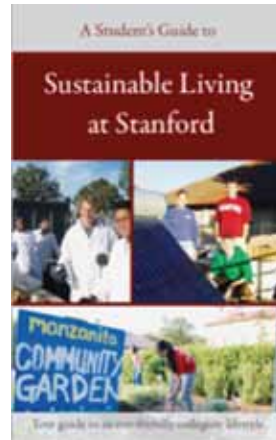

## Zone Management Exceeds \$1.4M Energy Savings Target

In 2009, as part of the budget savings initiatives within [Lands, Buildings and Real Estate](#), the Zone Management Team within [Buildings and Grounds Maintenance](#) proposed to save approximately \$1.4 million by reducing energy consumption for—electricity, steam, and chilled water—in the academic buildings. Sample efficiency measures included incorporation of lighting control, modification of zone-level temperature control, building time scheduling, and installation of energy-efficient lamps and ballasts as deliverables for [Investment in Plant](#) projects. Successful projects received rebates from Stanford's Energy Rebate Program and \$130,132 from the PG&E rebate program. Zone Management has exceeded the overall target goal of \$1.4 million with an investment payback of less than five years. The actual savings will be finalized in fall 2010. Zone Management is working towards standardizing practices, continuously monitoring mechanical systems, and performing regularly scheduled maintenance so that it can continue to improve existing building energy efficiency.

### More Information:

<http://lbre.stanford.edu/>

<http://bgm.stanford.edu/>

[http://bgm.stanford.edu/groups/zones/project\\_mgmt](http://bgm.stanford.edu/groups/zones/project_mgmt)





## Stanford Dining Publishes “Sustainability: A Way of Life” Booklet

Stanford’s Residential & Dining Enterprises published “[Sustainability: A Way of Life](#),” a booklet dedicated to the numerous avenues through which food impacts the Stanford community. The sustainability report provides a detailed look at education, outreach, and awareness; collaboration and partnerships; and wellness and culinary excellence. A great resource for students, faculty, and staff, the booklet explains everything from where and how Stanford Dining and Stanford Hospitality and Auxiliaries source food to the operation of campus gardens, and how both organizations contribute to the university’s waste reduction goals.

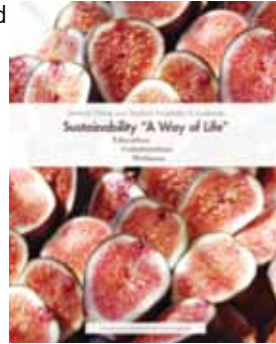

### More Information:

[http://www.stanford.edu/dept/rde/dining/pdfs/2010\\_SustainabilityReport.pdf](http://www.stanford.edu/dept/rde/dining/pdfs/2010_SustainabilityReport.pdf)

<http://www.stanford.edu/dept/rde/dining/index.htm>

<http://sustainable.stanford.edu/food>



## Stanford’s Car-Sharing Program Largest Among Universities

With 35 cars at 15 locations across campus, Stanford has the biggest university car-sharing program nationally. Stanford established the [Zipcar Program](#) three years ago, and it continues to expand due to popular demand from students, faculty, and staff. Zipcar is the nation’s leading on-demand car-sharing provider. Stanford has negotiated special rates and bonuses for Stanford affiliates, just \$8 per hour for weekday rentals, including gas and insurance. The following are bonus programs Zipcar offers to Stanford affiliates:

- ◉ All Stanford faculty, staff, and students receive \$35 in driving credit for the first year when they join Zipcar with a \$35 membership fee.
- ◉ Stanford Commute Club members receive an additional \$8 per month in Zipcar driving credit—up to \$96 per year—when registered as Stanford Commute Club Zipcar members.
- ◉ Each Stanford department receives a free Zipcar membership, and Stanford Resident Assistants (RAs) and Community Associates (CAs) also receive free Zipcar memberships.

### More Information:

<http://transportation.stanford.edu/zipcar>

<http://sustainable.stanford.edu/transportation>





## Stanford Joins STARS Program as Charter Member

Stanford elected to become a charter participant in a new rating system to encourage sustainability in all aspects of higher education. The program, called the [Sustainability, Tracking, Assessment & Rating System](http://stars.aashe.org/) (STARS), is administered by the Association for the Advancement of Sustainability in Higher Education (AASHE). The AASHE STARS program is the only campus-wide sustainability rating system that involves publicly reporting comprehensive information related to a college or university's sustainability performance. Participants report achievements in three overall areas: education and research; operations; and planning, administration, and engagement. Unlike other rating or ranking systems, the AASHE STARS program is open to all institutions of higher education in the U.S. and Canada, and the criteria that determine a STARS rating are transparent and accessible to the general public. The STARS program facilitates internal comparisons as well as comparisons with similar institutions. The Office of Sustainability will maintain and manage the STARS reporting process.



### More Information:

<http://stars.aashe.org/>  
<http://www.aashe.org/>



## Initial Occupants Move into Olmsted Terrace Faculty Homes & Olmsted Road Staff Rentals

Design for the [Olmsted Terrace](http://olmstedterrace.stanford.edu/sustainability/index.php) Faculty Homes project, consisting of 39 single-family residences, and the [Olmsted Road](http://olmstedhomes.stanford.edu/overview.html) Staff Rentals project, consisting of 25 single-family residences, targeted water conservation, energy efficiency, and high development density. Set for full occupancy in the fall, both projects minimized impact to the surrounding community, through measures such as preserving a significant number of mature oak trees during construction. Significant sustainability features include:

- ◉ ENERGY STAR building envelopes (exceeding State of California energy standards by at least 15%)
- ◉ ENERGY STAR appliance packages and low-flow toilets
- ◉ Lake-water irrigation with satellite control
- ◉ Extensive planting of native and adaptive species of shade trees to reduce heat gain in the homes

### More Information:

<http://olmstedterrace.stanford.edu/sustainability/index.php>  
<http://olmstedhomes.stanford.edu/overview.html>



## Third Party Evaluations



**Sustainable Endowment Institute Top Tier:** 2007, 2009, and 2010

**Sierra Club Fifth Place in 2010:** Achieved a 5th-place ranking out of 162 schools surveyed.

**U.S. Green Building Council and Princeton Review 2010:** Stanford is included in the Princeton Review's Guide to 286 Green Colleges, produced in partnership with the USGBC and released on Earth Day 2010. The Energy and Climate Plan, A Student's Guide to Sustainable Living, and the CEE/ES 109 Green Buildings & Behavior course were a few of the new items Stanford highlighted in this year's survey response. The Princeton Review specifically highlights Stanford's transportation demand management program and building-level energy conservation programs.

**Greenopia Top 10 in 2009 (Three Leaves):** Achieved a Top 10 ranking out of 100 schools surveyed.

**Discovery Communications Honor Roll 2009:** Achieved a Top 10 ranking.

**Sierra Club "A-" Grade in 2009:** Achieved a 26th-place ranking out of 135 schools surveyed.

## Buildings



**ASHRAE Technology Award, Honorable Mention,** for the Stauffer Building I laboratory VAV conversion (2010)

**Merit Award,** with Boora Architects, for SEQ, Planning for a District or Campus Component, Society for College and University Planning (2010)

**Best Green Building in the Bay Area,** for Y2E2, San Francisco Business Times (March 2008)

**Top Ten Green Projects,** for Jasper Ridge Field Station, American Institute of Architects Committee on the Environment (2005)

**Energy & Sustainability Award,** for Jasper Ridge Field Station, American Institute of Architects, San Francisco Chapter (2005)

## Energy



**Y2E2 photovoltaic project,** \$38,000 rebate from PG&E (2009)

**1st Place, 2008–2009 ASHRAE X Technology Award,** for the Stauffer Chemistry Building HVAC retrofit project

**Avery Aquatic Center pump retrofit project,** \$110,000 rebate from PG&E (2009)

**Stauffer Physical Chemistry Buildings HVAC retrofit project,** \$110,000 rebate from PG&E (2008)

**Stauffer Chemistry Building HVAC retrofit project,** \$180,000 rebate from PG&E (2007)

**Honorable Mention, Flex Your Power Awards** (2005)

**Reservoir 2 photovoltaic project,** \$135,000 rebate from PG&E (2004)

**Business Continuity Data Center,** \$48,000 rebate from PG&E (2009)

**School of Medicine Server Virtualization Project,** \$8,988 rebate from PG&E (2009)

**Desktop Power Management,** \$55,000 rebate from PG&E (2008)

## Food



**Stanford Hospitality and Auxiliaries:** Stanford Catering Chef Andrew Mayne was an invited chef at the Monterey Bay Aquarium's "Cooking for Solutions" Event (2009)

**Stanford Dining:** Stanford Dining's executive director, Eric Montell, served as a judge for the Acterra Sustainability Awards (2008 and 2009)

**Stanford Dining:** Acterra Business Environmental Award for Sustainability (2007)

**Special Congressional Recognition:** Anna Eshoo (2007)

**Leadership in Applying Green Building Design:** PG&E (2006)

**Stanford Dining:** one of the first university food service operations in the United States certified as a green business by Santa Clara County (2004)

## Land



**Best Green Buildings in the Bay Area - Y2E2,** San Francisco Business Times (2008)

**Site Design for Storm Water Pollution Prevention,** Santa Clara Valley Urban Runoff Pollution Prevention Program (2007)

**Governor's Historic Preservation Award,** for Historic Houses Project of Faculty Houses, State of California (2007)

**Special Recognition,** for oak reforestation project partnership, U.S. Congress (2006). The project also received commendations from the State Assembly and Senate, and San Mateo and Santa Clara counties.

**Seismic Strengthening & Historic Restoration Award,** National Trust for Historic Preservation (2001)

**Design Award,** for the stabilization and preservation of the Frank Lloyd Wright-designed Hanna House, California Preservation Foundation (2001)

## Research—Woods Institute Faculty Awards



### **Gretchen Daily Wins \$420,000 Award for Finding Ways to Save Biodiversity (July 2009)**

Stanford professor of biology and Woods Institute for the Environment senior fellow Gretchen Daily has won the International Cosmos Prize, awarded by the Expo '90 Foundation in Japan. Expo '90 lauded her as "a researcher who has provided us with a comprehensive picture of the value of biodiversity-based ecosystem services, upon which human society is dependent." The prize includes a commendation, a medallion, and 40 million yen (approximately \$420,000).

### **Chris Field Receives Heinz Award for Environmental Science and Leadership (September 2009)**

Christopher Field, a professor of biology and of environmental earth system science at Stanford University and a senior fellow at the Woods Institute for the Environment, has been named a 2009 Heinz Award recipient. The Heinz Family Foundation cited Field "for his leadership and innovation in carbon cycle and climate science."

### **Stanford Research Team Receives Funding to Study Energy Efficiency and Human Behavior (November 2009)**

The Department of Energy awarded Stanford researchers a grant to develop an interactive software system that encourages energy efficiency. The faculty research team includes Banny Banerjee (mechanical engineering), Martin Fischer (civil and environmental engineering), Abby King (medicine), Scott Klemmer (computer science), and Sam McClure and Gregory Walton (psychology)—recipients of 2008 planning grants from the Woods Institute and Precourt Energy Efficiency Center to develop behavior and public policy research components for a campus-wide initiative on the sustainable built environment.

### **Stanford Ecologist Paul Ehrlich to Receive the Ramon Margalef Prize in Spain (November 2009)**

Instead of pouring tax money into automobile industry bailouts, the government should invest in a new infrastructure to deal with changing climate patterns, says professor of ecology and Woods Institute for the Environment senior fellow Paul Ehrlich. Ehrlich spoke to the Stanford Report before leaving for Spain to receive the Ramon Margalef Prize for lifetime achievement in ecology and environmental sciences.

### **Peter Vitousek Accepts Japan Prize for Environmental Research (January 2010)**

In April 2010, biology professor and Woods Institute for the Environment senior fellow Peter Vitousek accepted the Japan Prize for pioneering work in biogeochemistry and global sustainability. The prize was awarded in Tokyo by the Science and Technology Foundation of Japan.

### **David Lobell Receives Macelwane Medal from American Geophysical Union (August 2010)**

Freeman Spogli Institute for International Studies and Woods Institute for the Environment Center fellow David Lobell was awarded the James B. Macelwane Medal from the American Geophysical Union for "significant contributions to the geophysical sciences by an outstanding young scientist (less than 36 years of age)."

## Transportation



**Best Workplaces for Commuters**, U.S. Environmental Protection Agency/Center for Urban Transportation Research at the University of Florida (2002–2010)

**Innovative Transportation Solutions Award**, WTS San Francisco Bay Area Chapter (2009)

**Excellence in Motion**, Award of Merit, Metropolitan Transportation Commission (2008)

**Bicycle Friendly Community**, League of American Bicyclists (2003–2007; Gold Level 2008–2012)

**Green Business Award** for the Stanford Fleet Garage, County of Santa Clara, recognizing commitment to environmentally responsible operations (2004–2007)

**Association for Commuter Transportation Leadership Award** for non-elected individual or private organization (2006)

**Best of Universities and Colleges and Gold Prize** for Transportation Coordinator, EPA/Department of Transportation Best Workplaces for Commuters' Race to Excellence (2006)

**"Top 50" Award** for Regional Transportation, employer category, Bay Area Council (2004)

**Clean Air Award**, American Lung Association of the Bay Area (2003)

## Waste



**American Forest and Paper Association**, College/University Recycling Award (2009)

In the **RecycleMania 2010** contest, Stanford scored in the top 25 in six of the eight categories: per capita (21); gorilla (3); paper (11); cardboard (20); bottles and cans (23); and food waste (6)

In the **RecycleMania 2009** contest, Stanford scored in the top 20 in five of the eight categories: per capita (16); gorilla (3); paper (9); cardboard (17); and food waste (6)

**1st Place, Gorilla Prize, RecycleMania Contest for Colleges and Universities**, for highest gross weight (1.24 million pounds) of diverted recyclables (2008)

**2nd Place, Gorilla Prize, RecycleMania Contest for Colleges and Universities**, for second-highest gross weight (1.356 million pounds) of diverted recyclables and 3rd place for paper recycling (25.38 pounds per person) (2007)

**EPA Environmental Achievement Award** for Battery Recycling and Mercury Thermometer Replacement Program by Environmental Health and Safety (2002)

## Water



**Silicon Valley Water Conservation Award** in the Large Organization category (2009)

**Clean Bay Business Award**, for the Stanford Golf Course Maintenance Shop and the Fleet Garage and Service Station, Palo Alto Regional Water Quality Control Plant (2001–2010)

**Leadership recognition**, for eliminating the use of antibacterial soaps, Palo Alto Regional Water Quality Control Plant (2007)

**Santa Clara Valley Urban Runoff Pollution Prevention Program Award**, for the site design for storm water pollution prevention at Stanford Stadium (2007)

## INDEX

## Behavior



Behavioral Sustainability Program Pilot Expands to Arrillaga Alumni Center	18
Behavioral Sustainability Program Pilot Expands to Departments: IT Services Tackles Nine Buildings	15
Behavioral Sustainability Program Pilot Expands to the School of Earth Sciences	63
Behavioral Training Provided at Annual Building Managers' Meeting	48
Office of Sustainability Partners with Woods Institute to Launch CEE/ES 109 Green Buildings & Behavior Course	39
Student Sustainability Town Hall Meeting Tradition Continues	23

## Buildings



Behavioral Sustainability Program Pilot Expands to the School of Earth Sciences	63
Behavioral Training Provided at Annual Building Managers' Meeting	48
Initial Occupants Move into Olmsted Terrace Faculty Homes & Olmsted Road Staff Rentals	87
Li Ka Shing Center for Learning and Knowledge Project Complete	49
Lorry I. Lokey Stem Cell Research Building Complete: Laboratory Fit-Up Begins	78
Materials Conservation Project Under Way at Historic Hanna House	67
Materials Salvage, Reuse and Building Infill Projects Continue	45
Monitoring System Extends to New and Existing Buildings	46
SEQ Opens to Pedestrian Traffic	66
Stauffer Chemistry Building Project Wins 2010 ASHRAE Technology Award Honorable Mention	75
Students' Residential Solar Water Heater Installation Complete: Data Analysis in Progress	16
Sustainable Stanford Presents at Silicon Valley Energy Summit	70
The New Business School En Route to LEED Platinum Rating	34
Y2E2 Solar Installation Earns Rebate from California Solar Initiative	17

## Climate Action



Aggressive Energy and Climate Plan Unveiled	31
Climate Change Featured as Central Theme of Annual Walk the Farm Tour	59
Climate-Conscious Food Week Underscores Impact of Food Choices	29
Diesel-Electric Hybrid Buses Join Marguerite Fleet	22
Energy Secretary Steven Chu's Speech Inspires Energy Revolution	47



First Regional Heat Exchange Station Opens	81
FutureFest Celebrates Earth Week	54
Graduate School of Business Celebrates Earth Day with Low Carbon Diet Day	58
Monitoring System Extends to New and Existing Buildings	46
President's Column Highlights Energy and Climate Plan	40
Progress Continues with Central Plant Optimization Project as Part of 2009 Energy and Climate Plan	76
Record Ridership on Bike to Work Day	61
Research: Sustainable Sewage Treatment	77
Stanford Competes in the Great Race for Clean Air	79
Stanford's Housing Stock Facilitates Local Compliance with AB 375	73
Students Compete in Sixth Annual Conservation Cup	41
Students Embrace International Day of Climate Action	28
Students Experience Climate Policy in Action at Copenhagen Conference	38
University Employee Drive-Along Rate Drops to 48%	64
Zone Management Exceeds \$1.4M Energy Savings Target	83

## Community Outreach



Climate Change Featured as Central Theme of Annual Walk the Farm Tour	59
First Podcast Tour of Campus Plants, Animals, and Science Art	35
Habitat Conservation Plan Draft Released for Public Review	51
Inaugural Sustainability Tour at Reunion Homecoming Weekend 2009	25
Materials Conservation Project Under Way at Historic Hanna House	67
Stanford Hosts and Helps Green the 2009 Summer National Senior Games	14
Stanford's Housing Stock Facilitates Local Compliance with AB 375	73

## Energy



2009–2010 Student Green Fund Winners Announced	32
Aggressive Energy and Climate Plan Unveiled	31
Annual Winter Closure Saves Utility Charges	37
Behavioral Sustainability Program Pilot Expands to Arrillaga Alumni Center	18
Behavioral Sustainability Program Pilot Expands to Departments: IT Services Tackles Nine Buildings	15
Behavioral Sustainability Program Pilot Expands to the School of Earth Sciences	63
Behavioral Training Provided at Annual Building Managers' Meeting	48
Forsythe Data Center Earns Rebate Check for Sustainable IT Efficiency Measures	74
FutureFest Celebrates Earth Week	54

High-Efficiency Outdoor Lighting Piloted Across Campus	50
Inaugural Sustainability Tour at Reunion Homecoming Weekend 2009	25
Increased Operational Robustness in Department of Sustainability and Energy Management	43
Initial Occupants Move into Olmsted Terrace Faculty Homes & Olmsted Road Staff Rentals	87
Li Ka Shing Center for Learning and Knowledge Project Complete	49
Lorry I. Lokey Stem Cell Research Building Complete: Laboratory Fit-Up Begins	78
Monitoring System Extends to New and Existing Buildings	46
Office of Sustainability Partners with Woods Institute to Launch CEE/ES 109 Green Buildings & Behavior Course	39
President's Column Highlights Energy and Climate Plan	40
Progress Continues with Central Plant Optimization Project as Part of 2009 Energy and Climate Plan	76
Research: Electrode with Implications for Solar Photovoltaic Technology Earns C3Nano MIT Clean Energy Prize	60
SEQ Opens to Pedestrian Traffic	66
Stauffer Chemistry Building Project Wins 2010 ASHRAE Technology Award Honorable Mention	75
Students Compete in Sixth Annual Conservation Cup	41
Student's Guide to Sustainable Living at Stanford Updated and Sent to Incoming Class of 2014	82
Students' Residential Solar Water Heater Installation Complete: Data Analysis in Progress	16
Sustainable Information Technology Highlighted at Nationwide EDUCAUSE Conference	26
Sustainable Stanford Presents at Silicon Valley Energy Summit	70
The New Business School En Route to LEED Platinum Rating	34
Y2E2 Solar Installation Earns Rebate from California Solar Initiative	17
Zone Management Exceeds \$1.4M Energy Savings Target	83

## Evaluations



"Best Workplaces for Commuters" Title Repeated	33
Open Letter Calls Attention to Fair Third-Party Sustainability Evaluations	72
Stanford Included in the USGBC and Princeton Review Guide to 286 Green Colleges	56
Stanford in Top Tier on Sustainable Endowments Institute 2010 College Sustainability Report Card	24
Stanford Joins STARS Program as Charter Member	86
Stanford Ranked Among Discovery Communications' 10 Greenest Colleges	13

Stanford Ranks Fifth in Sierra Magazine Sustainability Survey	80
Stanford Wins "Race to Excellence" Awards from Best Workplaces for Commuters	36
Two Campus Locations Win Clean Bay Business Award	55

## Events



Greening Events at Stanford Guidebook Published	57
Inaugural Sustainability Tour at Reunion Homecoming Weekend 2009	25
Stanford Hosts and Helps Green the 2009 Summer National Senior Games	14

## Food



2009–2010 Student Green Fund Winners Announced	32
Behavioral Training Provided at Annual Building Managers' Meeting	48
Climate-Conscious Food Week Underscores Impact of Food Choices	29
FutureFest Celebrates Earth Week	54
Graduate School of Business Celebrates Earth Day with Low Carbon Diet Day	58
Greening Events at Stanford Guidebook Published	57
Office of Sustainability Partners with Woods Institute to Launch CEE/ES 109 Green Buildings & Behavior Course	39
Stanford Dining Publishes "Sustainability: A Way of Life" Booklet	84
Zero-Waste Program Launched: Three Dining Locations Pilot Effort	44

## Investments



First Regional Heat Exchange Station Opens	81
Increased Operational Robustness in Department of Sustainability and Energy Management	43
Progress Continues with Central Plant Optimization Project as Part of 2009 Energy and Climate Plan	76
Stanford Leads Stand Against Conflict Minerals: Board of Trustees Adopts Proxy Voting Guideline	65

## Land



Climate Change Featured as Central Theme of Annual Walk the Farm Tour	59
First Podcast Tour of Campus Plants, Animals, and Science Art	35
Habitat Conservation Plan Draft Released for Public Review	51
Materials Conservation Project Under Way at Historic Hanna House	67
Materials Salvage, Reuse and Building Infill Projects Continue	45
Stanford's Housing Stock Facilitates Local Compliance with AB 375	73

## Purchasing



Greening Events at Stanford Guidebook Published	57
---	----

## Research



2009–2010 Student Green Fund Winners Announced	32
Research: Electrode with Implications for Solar Photovoltaic Technology Earns C3Nano MIT Clean Energy Prize	60
Research: Electric and Fuel Cell Vehicle Showcase Highlights Race for Sustainable Automobiles	52
Research: Overuse of Fertilizers May Catalyze Waterborne Diseases	19
Research: Sustainable Sewage Treatment	77
Research: The Impact of Fishing on Coral Reefs	71
Research: Tracing the Source of Coastal Pollution in Hawaii	62
Students Install Anemometer Tower in Salinas Valley to Quantify Wind Resource	21
Students' Residential Solar Water Heater Installation Complete: Data Analysis in Progress	16
Woods Institute Announces Four New Grants	68

## Students



2009–2010 Student Green Fund Winners Announced	32
Climate-Conscious Food Week Underscores Impact of Food Choices	29
"Ditch that Dumpster" Event Prominent Feature of Green Move-Out	69
Energy Secretary Steven Chu's Speech Inspires Energy Revolution	47
FutureFest Celebrates Earth Week	54
Green Living Council Launches Green Screens Series	30
Office of Sustainability Partners with Woods Institute to Launch CEE/ES 109 Green Buildings & Behavior Course	39
Research: Electric and Fuel Cell Vehicle Showcase Highlights Race for Sustainable Automobiles	52
Stanford Leads Stand Against Conflict Minerals: Board of Trustees Adopts Proxy Voting Guideline	65
Student Initiative to Include Sustainability in Curriculum Considered by Faculty Senate Subcommittee	53
Students Compete in Sixth Annual Conservation Cup	41
Students Embrace International Day of Climate Action	28
Students Experience Climate Policy in Action at Copenhagen Conference	38

Student's Guide to Sustainable Living at Stanford Updated and Sent to Incoming Class of 2014	82
Students' Residential Solar Water Heater Installation Complete: Data Analysis in Progress	16
Student Sustainability Town Hall Meeting Tradition Continues	23
Sustainability Featured at New Student Orientation	20

## Sustainable IT



Behavioral Sustainability Program Pilot Expands to the School of Earth Sciences	63
Forsythe Data Center Earns Rebate Check for Sustainable IT Efficiency Measures	74
Sustainable Information Technology Highlighted at Nationwide EDUCAUSE Conference	26

## Transportation



"Best Workplaces for Commuters" Title Repeated	33
Diesel-Electric Hybrid Buses Join Marguerite Fleet	22
Research: Electric and Fuel Cell Vehicle Showcase Highlights Race for Sustainable Automobiles	52
Self-Service Bike Repair Station Opens on Campus	27
Stanford Competes in the Great Race for Clean Air	79
Stanford's Car-Sharing Program Largest Among Universities	85
Stanford Wins "Race to Excellence" Awards from Best Workplaces for Commuters	36
University Employee Drive-Along Rate Drops to 48%	64

## Waste



2009–2010 Student Green Fund Winners Announced	32
Behavioral Sustainability Program Pilot Expands to Arrillaga Alumni Center	18
Climate-Conscious Food Week Underscores Impact of Food Choices	29
"Ditch that Dumpster" Event Prominent Feature of Green Move-Out	69
FutureFest Celebrates Earth Week	54
Greening Events at Stanford Guidebook Published	57
Li Ka Shing Center for Learning and Knowledge Project Complete	49
Materials Salvage, Reuse and Building Infill Projects Continue	45
Office of Sustainability Partners with Woods Institute to Launch CEE/ES 109 Green Buildings & Behavior Course	39
SEQ Opens to Pedestrian Traffic	66
Stanford Posts Strong Results in Annual RecycleMania Competition	42

Student's Guide to Sustainable Living at Stanford Updated and Sent to Incoming Class of 2014	82
The New Business School En Route to LEED Platinum Rating	34
Zero-Waste Program Launched: Three Dining Locations Pilot Effort	44

## Water



2009–2010 Student Green Fund Winners Announced	32
Aggressive Energy and Climate Plan Unveiled	31
Behavioral Training Provided at Annual Building Managers' Meeting	48
First Regional Heat Exchange Station Opens	81
Forsythe Data Center Earns Rebate Check for Sustainable IT Efficiency Measures	74
FutureFest Celebrates Earth Week	54
Initial Occupants Move into Olmsted Terrace Faculty Homes & Olmsted Road Staff Rentals	87
Li Ka Shing Center for Learning and Knowledge Project Complete	49
Lorry I. Lokey Stem Cell Research Building Complete: Laboratory Fit-Up Begins	78
Office of Sustainability Partners with Woods Institute to Launch CEE/ES 109 Green Buildings & Behavior Course	39
Progress Continues with Central Plant Optimization Project as Part of 2009 Energy and Climate Plan	76
SEQ Opens to Pedestrian Traffic	66
Students Compete in Sixth Annual Conservation Cup	41
Student's Guide to Sustainable Living at Stanford Updated and Sent to Incoming Class of 2014	82
Two Campus Locations Win Clean Bay Business Award	55

The Office of Sustainability gratefully acknowledges contributions from the following organizations to this publication:

- ☉ Associated Students of Stanford University
- ☉ Buildings & Grounds Maintenance
- ☉ Graduate School of Business
- ☉ Green Alliance for Innovative Action
- ☉ Green Living Council
- ☉ Heritage Services
- ☉ Information Technology Services
- ☉ Land Use and Environmental Planning
- ☉ Peninsula Sanitary Service, Inc.
- ☉ Precourt Energy Efficiency Center
- ☉ Project Management
- ☉ Residential & Dining Enterprises
- ☉ School of Earth Sciences
- ☉ School of Medicine
- ☉ Stanford Alumni Association
- ☉ Stanford Solar and Wind Energy Project
- ☉ Students for Sustainable Stanford
- ☉ Sustainability and Energy Management
- ☉ Undergraduate Advising and Research
- ☉ University Architect / Campus Planning and Design
- ☉ University Communications
- ☉ Woods Institute for the Environment

## PHOTO CREDITS

Stanford News Service (Linda A. Cicero); Parking & Transportation Services; Office of Sustainability; Stanford Solar and Wind Energy Project; Stanford Alumni Association; Woods Institute for the Environment; Marguerite Shuttle Photo Contest Winner (Deyra N. Rodriguez); Julie Teel; Sustainable Information Technology; Residential & Dining Enterprises; Green Living Council; Campus Garden Initiative; Graduate School of Business; Students for a Sustainable Stanford; Student Housing; Peninsula Sanitary Service, Inc.; Associated Students of Stanford University; Department of Project Management; Power Systems; Land Use and Environmental Planning; Pat Brito, Design & Print Services; Facilities Energy Management.

*Sustainability practices at Stanford are built on the strong foundation of several decades of environmental stewardship in energy, water, transportation, housing, dining, waste, building and landscape management. With many measurable accomplishments underway, we are working together to transform our institutional choices and individual behavior to incorporate sustainability in every aspect of campus life.*

— FAHMIDA AHMED, OFFICE OF SUSTAINABILITY  
STANFORD UNIVERSITY



Printed on recycled paper.

Design and Production  
Pat Brito, Design & Print Services

*“Setting an example is not  
the main means of influencing others;  
it is the only means.”*

—ALBERT EINSTEIN

Office of Sustainability  
327 Bonair Siding  
Stanford, CA 94305

Office Hours: Every Monday 3:00 P.M. – 5:00 P.M.

Visit us online: <http://sustainable.stanford.edu/>



**SUSTAINABLE  
STANFORD**