



Micro-Algae Growth Technology Systems

Dr. Mustafa KIZILILSOLEY
mksoley@soley.cn
Dr. Soner HELVACIOGLU
soner@soley.cn

Presentation: Selim HELVACIOGLU



IIMSAM
Intergovernmental Institution
for the Use of Micro-algae
Spirulina
Against Malnutrition
<http://www.iimsam.org>

Micro-algae growth technology systems have been researched & developed since several decades in various designs for more efficient productions.

All of these micro-algae production designs have advantages and disadvantages, which should be considered.

This paper examines & compares the systems, which are still being used depending on land area needed, productivity values, advantages, disadvantages, tools needed, costs.



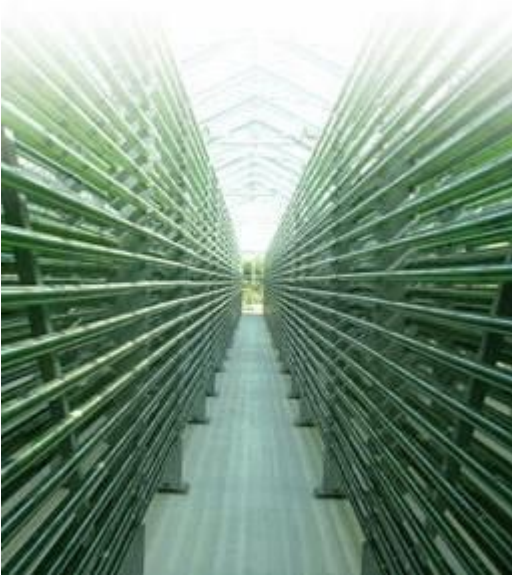

Micro-algae Growth Technology Systems

- Open Pond Systems
- Closed Pond Systems
- Tubular Systems
- Plastic Bag Systems
- Well Systems (Especially for chlorophyll reduced micro-algae)
- Pyramid Photobioreactor Systems

Open Pond Systems' General Properties

- Round or raceway built
- Mild mixing and waves
- Paddlewheel, waterjet or air pump systems could be used
- Optimal open pond dimensions are : 50 m. X 5 m. X 0,4 m. with 100 tons of water media
- Maximum spirulina productivity : **0,35 g/lt**
- 100 tons capacity pond = 35 kg/day**
- 250 m² area is required for 100 tons of water media
- These dimensions are used due to contamination risks, circulation & mixing problems
- These dimensions are useful in case of culture & medium & various problems, giving the possibility to divide these risks.
- Larger volume ponds have higher risks.

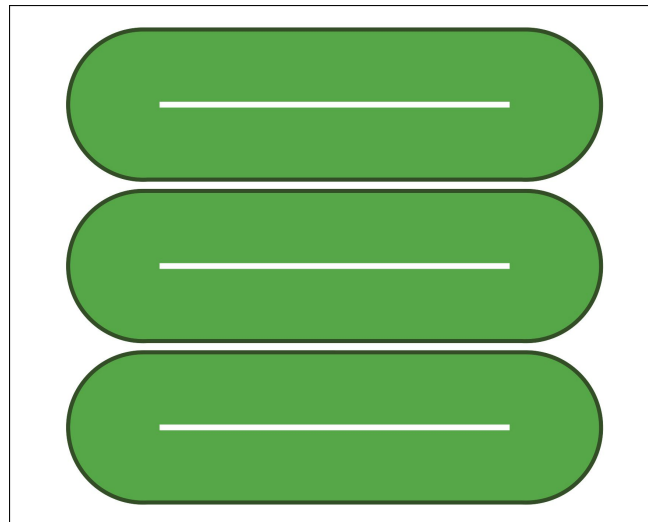



Materials Needed For Paddlewheel Driven Open Pond Systems

- Paddlewheel
- Isolation material (white colored, minimum 20 years resistant to chemicals, water proof)
- Starter chemicals
- Culture
- Hand-held conductivity-meter
- Hand-held pH-meter
- Hand-held algae-counter
- Algae filter (optional)
- Solar panels and/or wind mill(optional)



Paddlewheel Driven Open Pond System



Paddlewheel

Materials Needed For Waterjet Open Pond Systems

- Waterjet circulation pipe and mechanism
- Isolation material (white colored, minimum 20 years resistant to chemicals, water proof)
- Starter chemicals
- Culture
- Hand-held conductivity-meter
- Hand-held pH-meter
- Hand-held algae-counter
- Algae filter (optional)
- Solar panels and/or wind mill(optional)



Waterjet Open Pond System

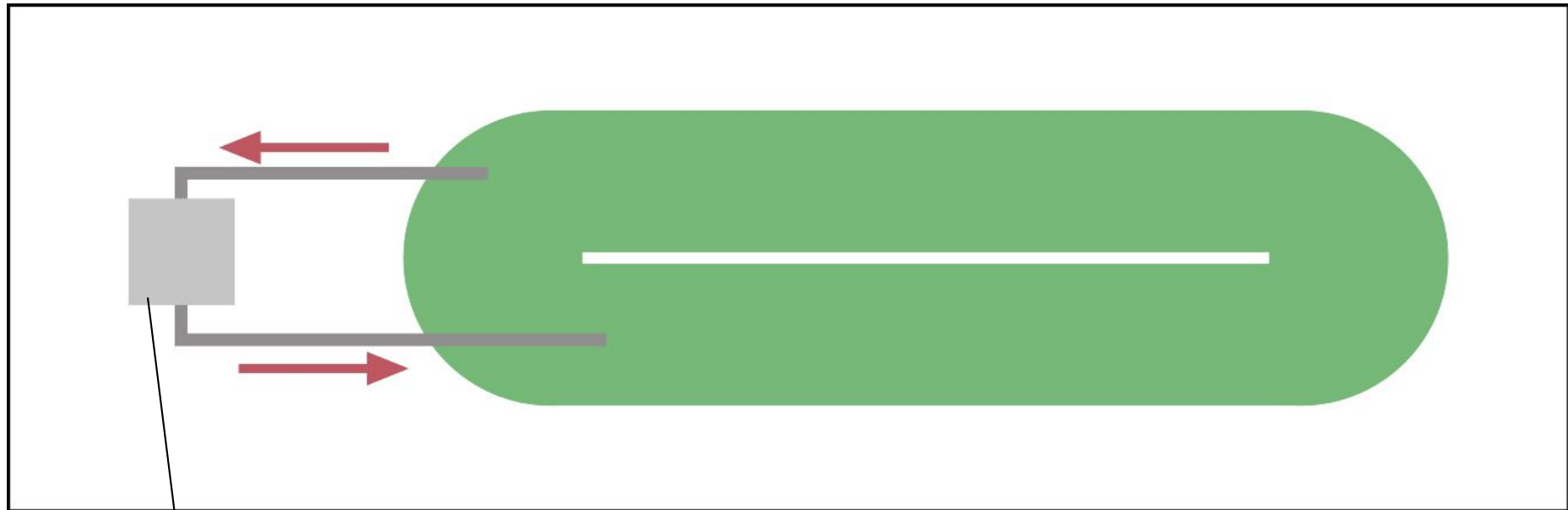

Waterjet for micro-algae

Materials Needed For Air Pump Open Pond Systems

- Oil-free air pump
- Air distribution pipes and mechanisms
- Isolation material (white colored, minimum 20 years resistant to chemicals, water proof)
- Starter chemicals
- Culture
- Hand-held conductivity-meter
- Hand-held pH-meter
- Hand-held algae-counter
- Algae filter (optional)
- Solar panels and/or wind mill(optional)

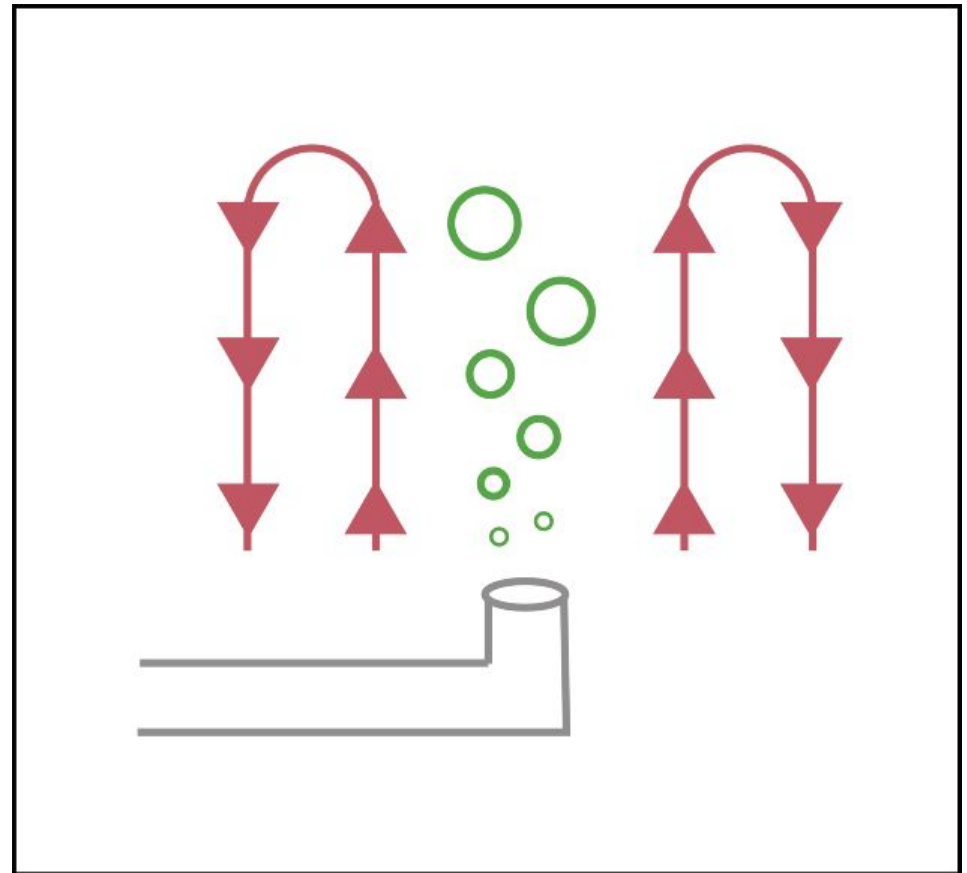
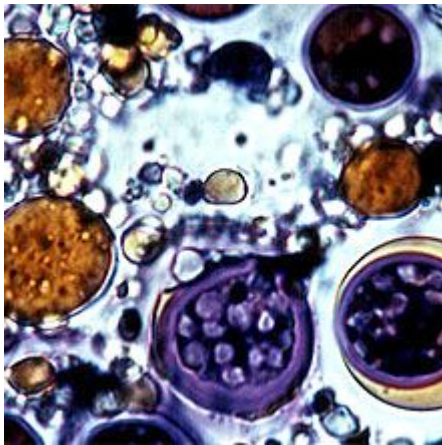

Air Pump Open Pond System

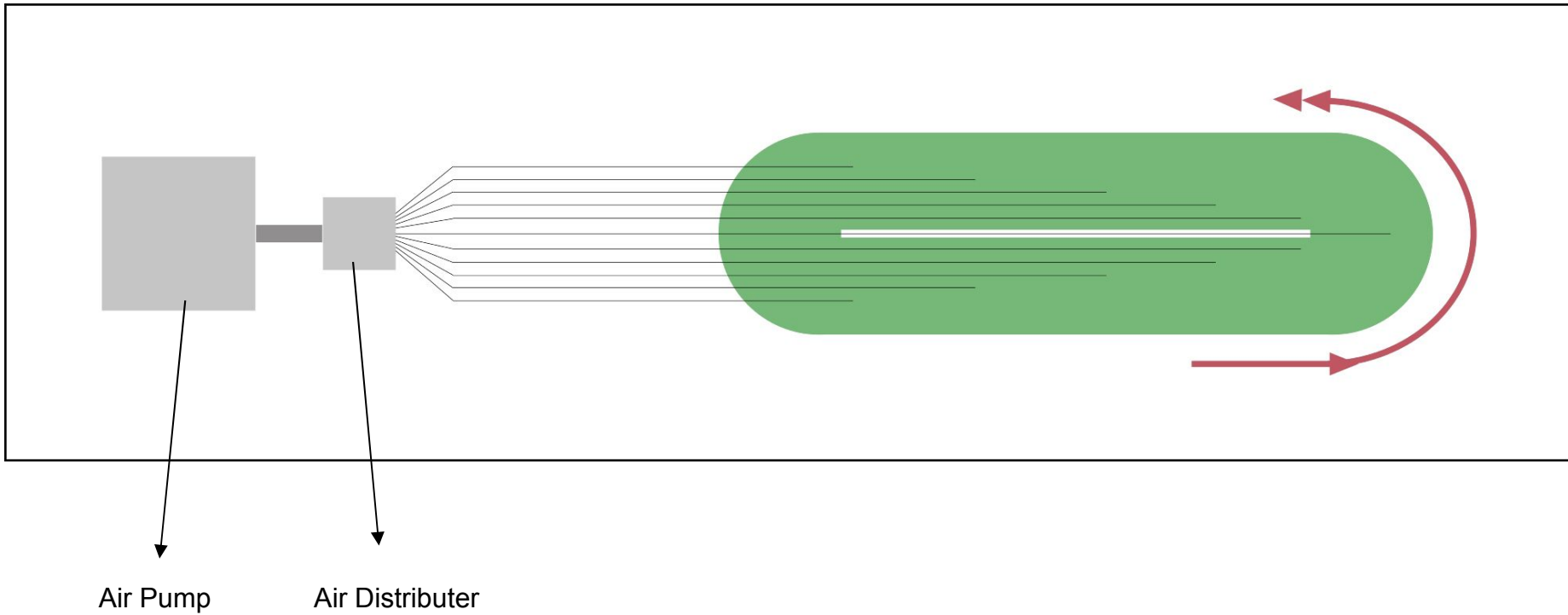

Closed Pond Systems' General Properties

- Round or raceway built
- Mild mixing and waves
- Paddlewheel, waterjet or air pump systems could be used
- Optimal open pond dimensions are : 50 m. X 5 m. X 0,4 m. with 100 tons of water media
- Maximum spirulina productivity : **0,35 g/lt**
- 100 tons capacity pond = 35 kg/day**
- 250 m² area is required for 100 tons of water media
- These dimensions are used due to contamination risks, circulation & mixing problems
- These dimensions are useful in case of culture & medium & various problems, dividing these risks.
- Larger volume ponds have higher risks.



Materials Needed For Closed Pond Systems

- Plexi-glass and metal construction materials
- Oil-free air pump or waterjet or paddlewheel
- Air or waterjet distribution/circulation pipes and mechanisms (not needed for paddlewheel)
- Isolation material (white colored, minimum 20 years resistant to chemicals, water proof)
- Starter chemicals
- Culture
- Hand-held conductivity-meter
- Hand-held pH-meter
- Hand-held algae-counter
- Algae filter (optional)
- Solar panels and/or wind mill(optional)

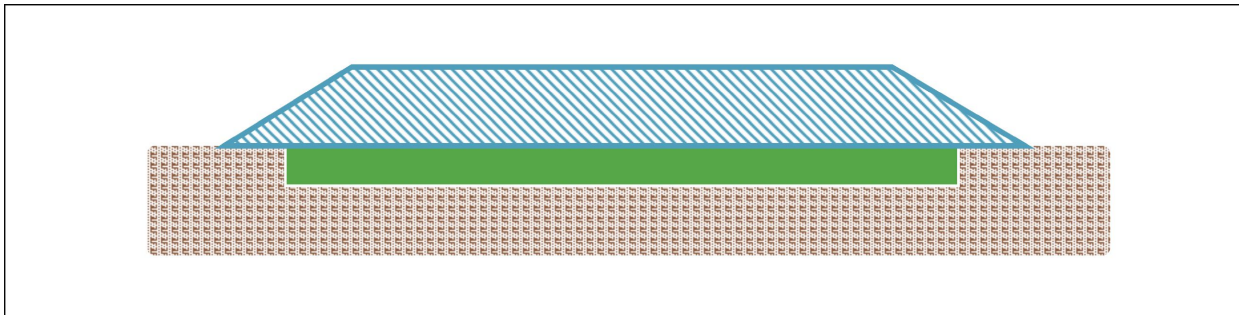

Closed Pond System

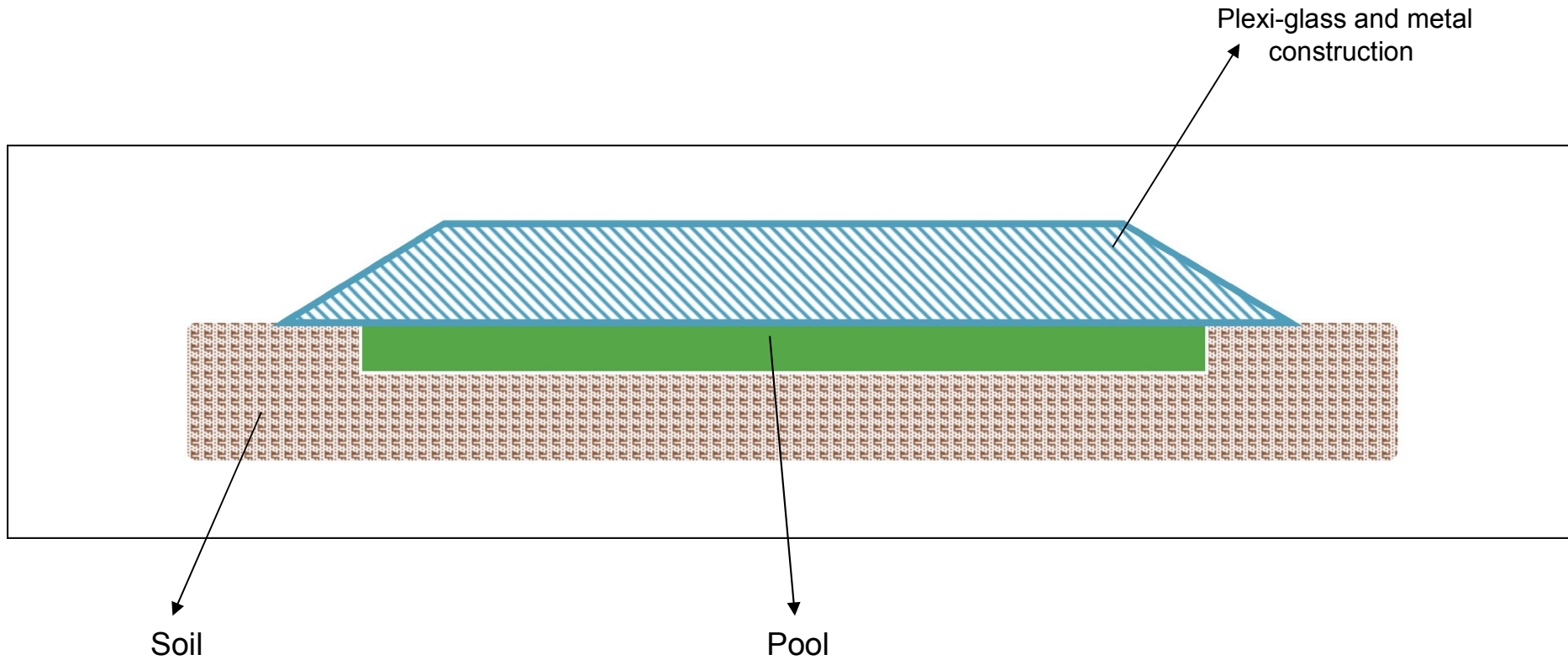

Tubular Systems' General Properties

- Vertical, parallel lined, acrylic tubes, max. 30 cm radius due to light penetration problems
- Motor-pump mixing
- Maximum spirulina productivity : **0,8 g/lt**
- 100 tons capacity tubular system = 80 kg/day**
- 1200 m² area required for 100 tons of water media

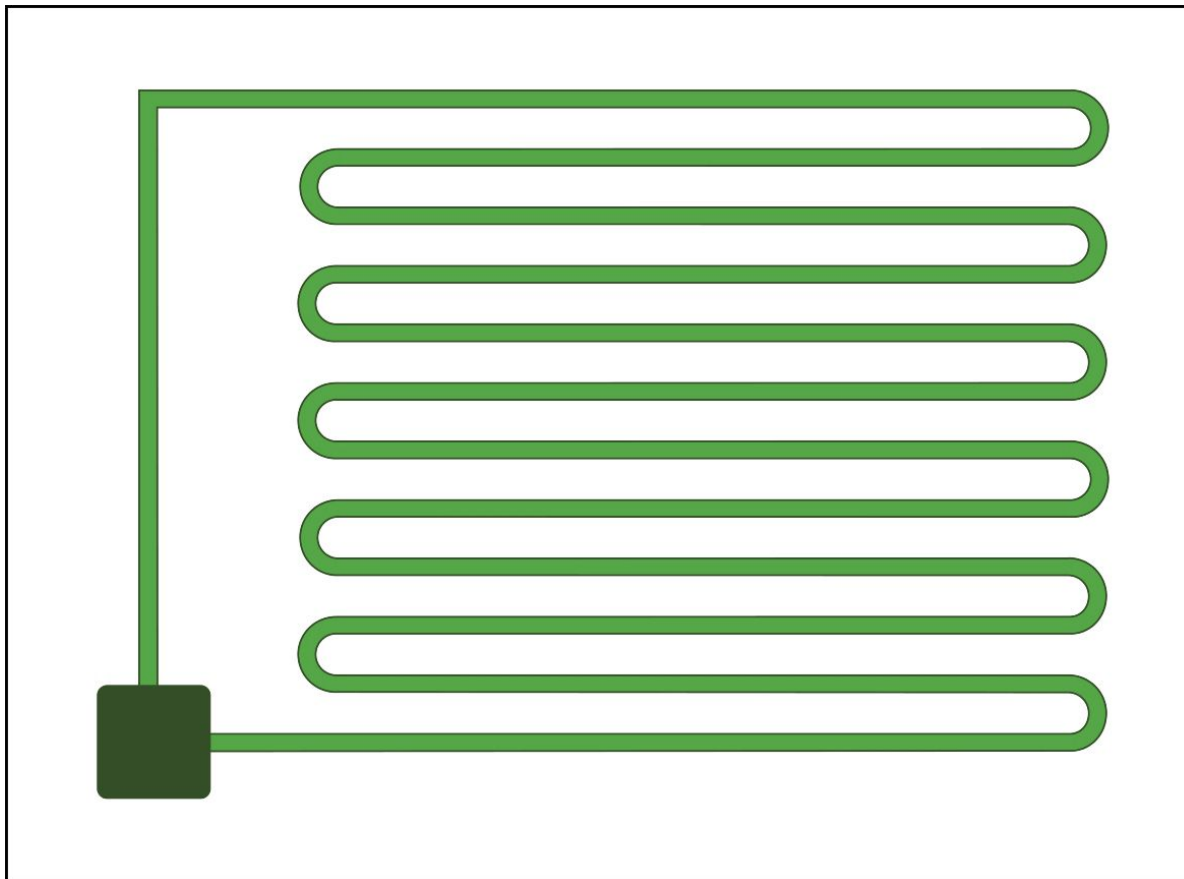

Materials Needed For Tubular Systems

Acrylic tubes

Motor-pump

Cooling unit

Harvesting filters

Medium control units

Computerized control panel

Starter chemicals

Culture

Conductivity-meter

pH-meter

Algae-counter

Algae filter (optional)

Solar panels and/or wind mill(optional)

Plexi-glass and metal construction materials (optional, needed for covered systems)

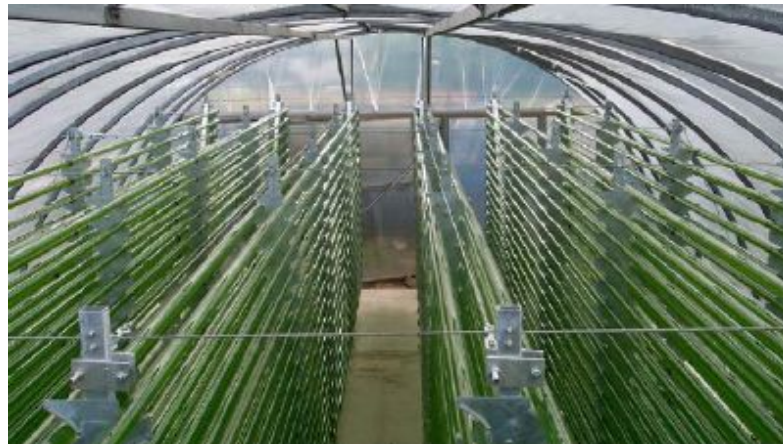
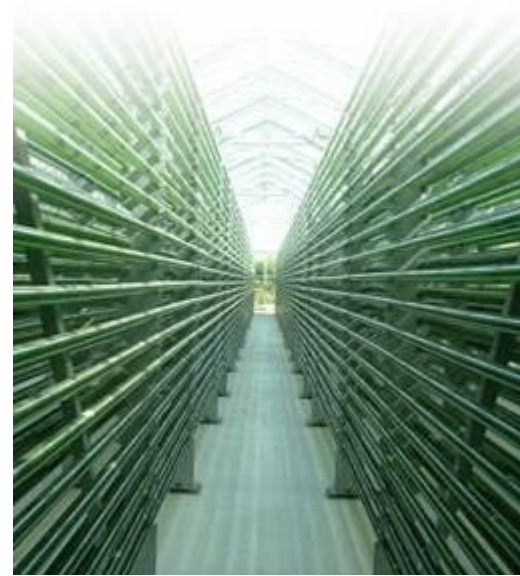

Plastic Bag Systems' General Properties

- Vertical, parallel lined, hanging plastic bags
- Circulation-pump is used
- Maximum spirulina productivity : **0,6 g/lit**
- 100 tons capacity tubular system = 60 kg/day**
- 1200 m² area required for 100 tons of water media



Materials Needed For Plastic Bag Systems

- Plastic Bags
- Circulation-pump
- Thermal tubes
- Cooling unit
- Harvesting filters
- Medium control units
- Computerized control panel
- Starter chemicals
- Culture
- Conductivity-meter
- pH-meter
- Algae-counter
- Algae filter (optional)
- Solar panels and/or wind mill(optional)
- Plexi-glass and metal construction materials



Plastic Bag System

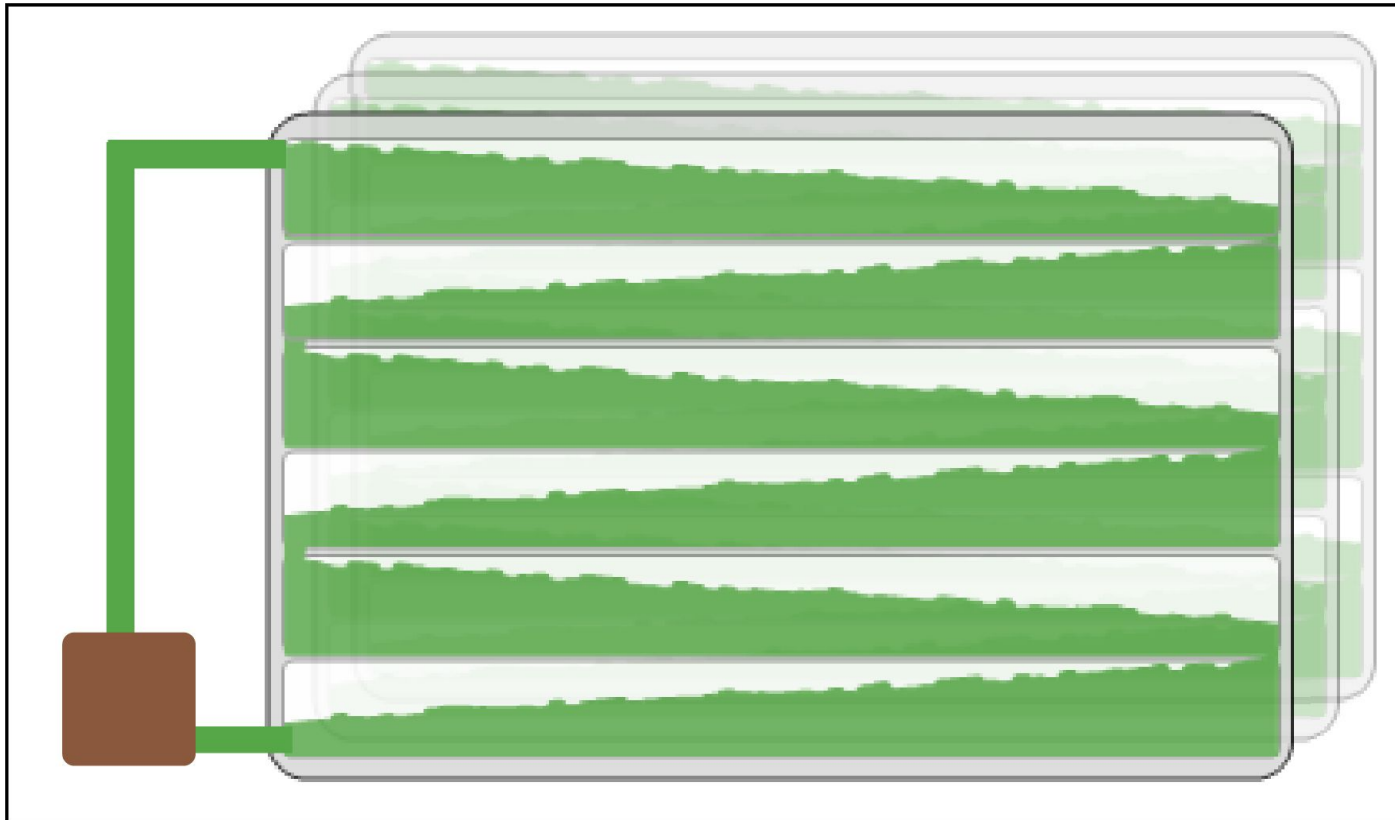

Plastic Bag System

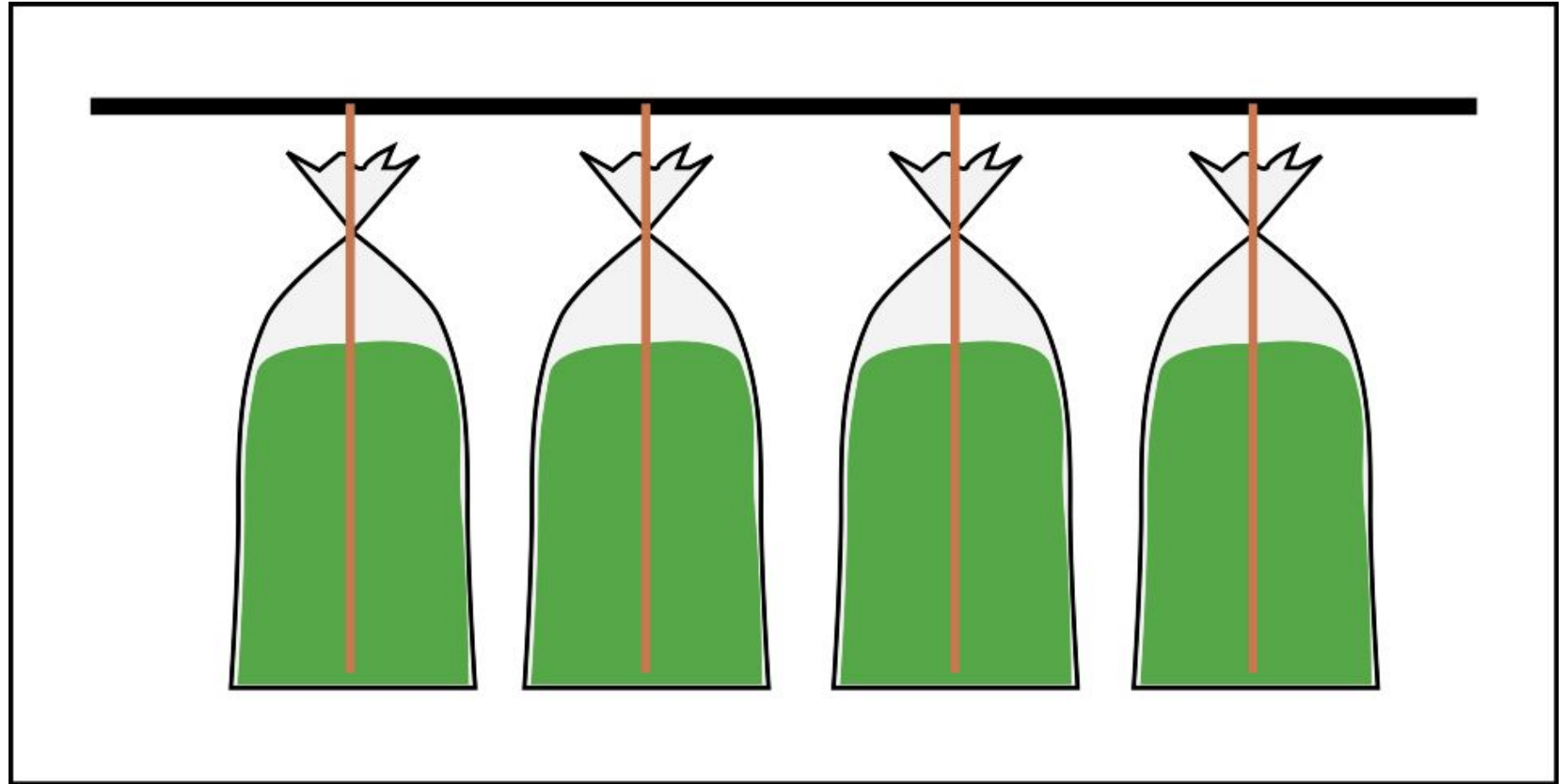

Well Systems' General Properties (Especially for chlorophyll reduced micro-algae)

- Underground constructed well system requiring less area and light
- Also suitable for landscapes such as **deserts**
- Air-pump mixing
- Optimal well dimensions are : 5 m. X 5 m. X 4 m. with 100 tons of water media
- 4 m. depth could be used due to more light penetration for chlorophyll reduced microalgae
- Maximum spirulina productivity : **0,9 g/lt**
- 100 tons capacity well system = 90 kg/day**
- 25 m² area required for 100 tons of water media

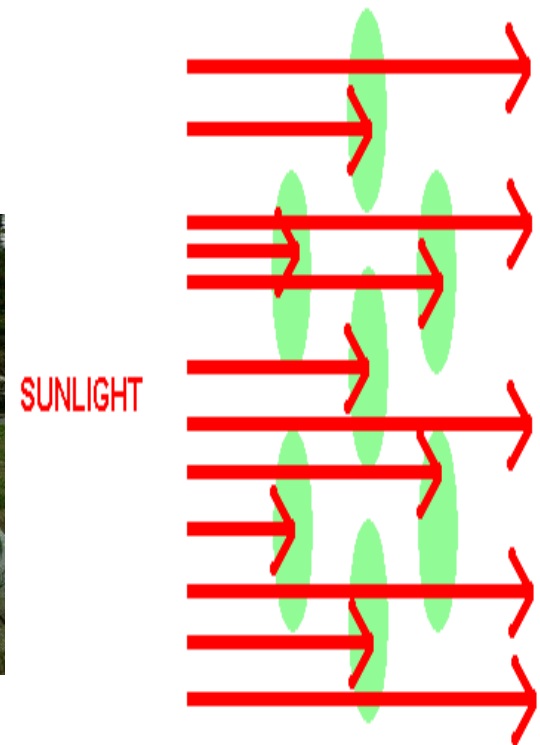
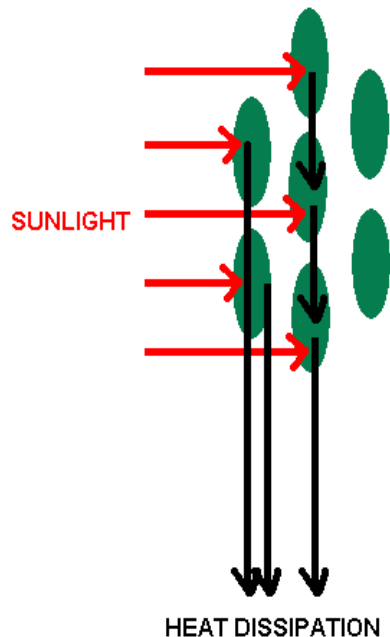

Materials Needed For Well Systems

- Underground well
- Metal tank
- Isolation material (white colored, minimum 20 years resistant to chemicals, water proof)
- Air-pump
- Starter chemicals
- Culture
- Hand-held conductivity-meter
- Hand-held pH-meter
- Hand-held algae-counter
- Algae filter (optional)
- Solar panels and/or wind mill(optional)
- Circulation-pump

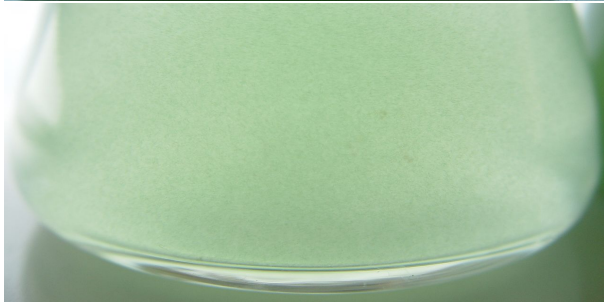

Normal Spirulina Culture

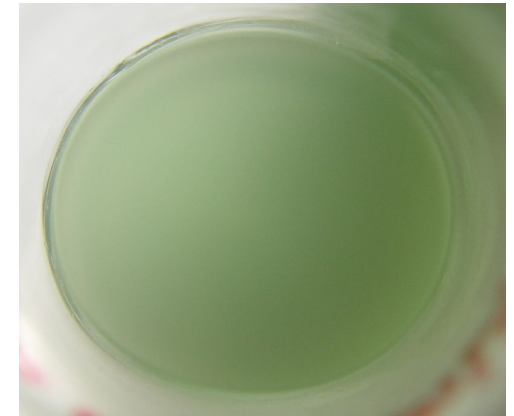
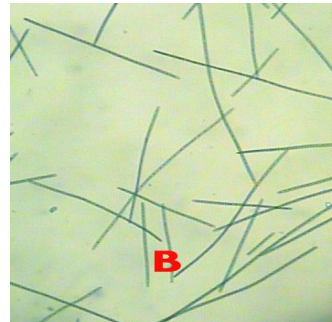

Chlorophyll Reduced
Spirulina Culture

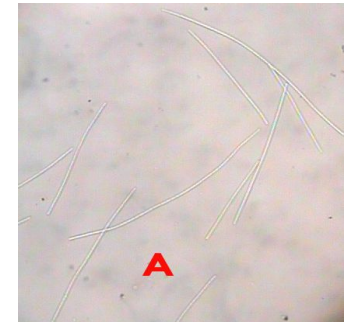

Well System

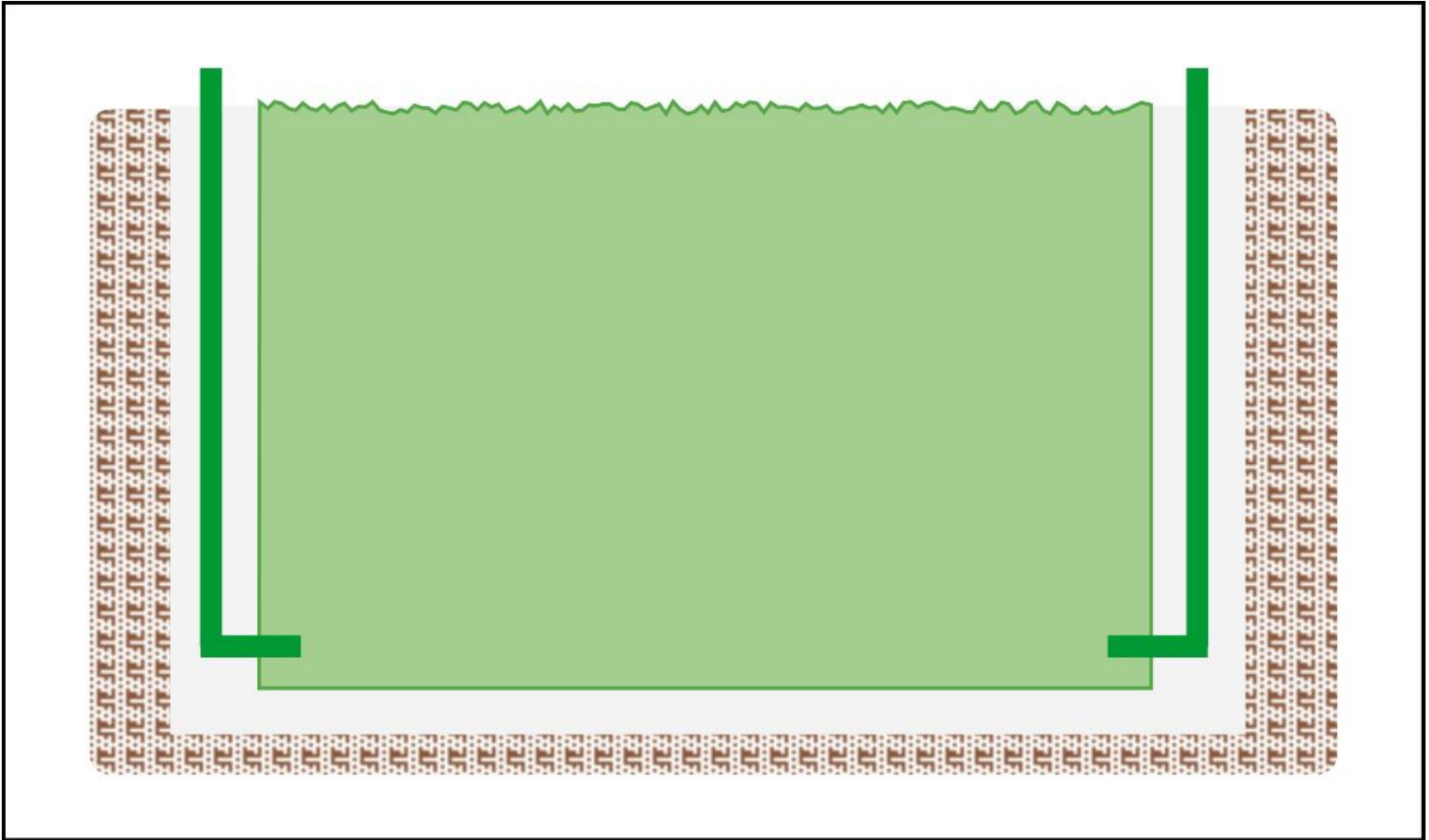

Pyramid Photobioreactor Systems' General Properties

- Fully automated-computerized, ultra-durable, latest technology photobioreactor system
- Airlift mixing is used
- Maximum spirulina productivity : **1,45 g/lt**
- 100 tons capacity pond = 145 kg/day**
- 60 m² area is required for 100 tons of water media

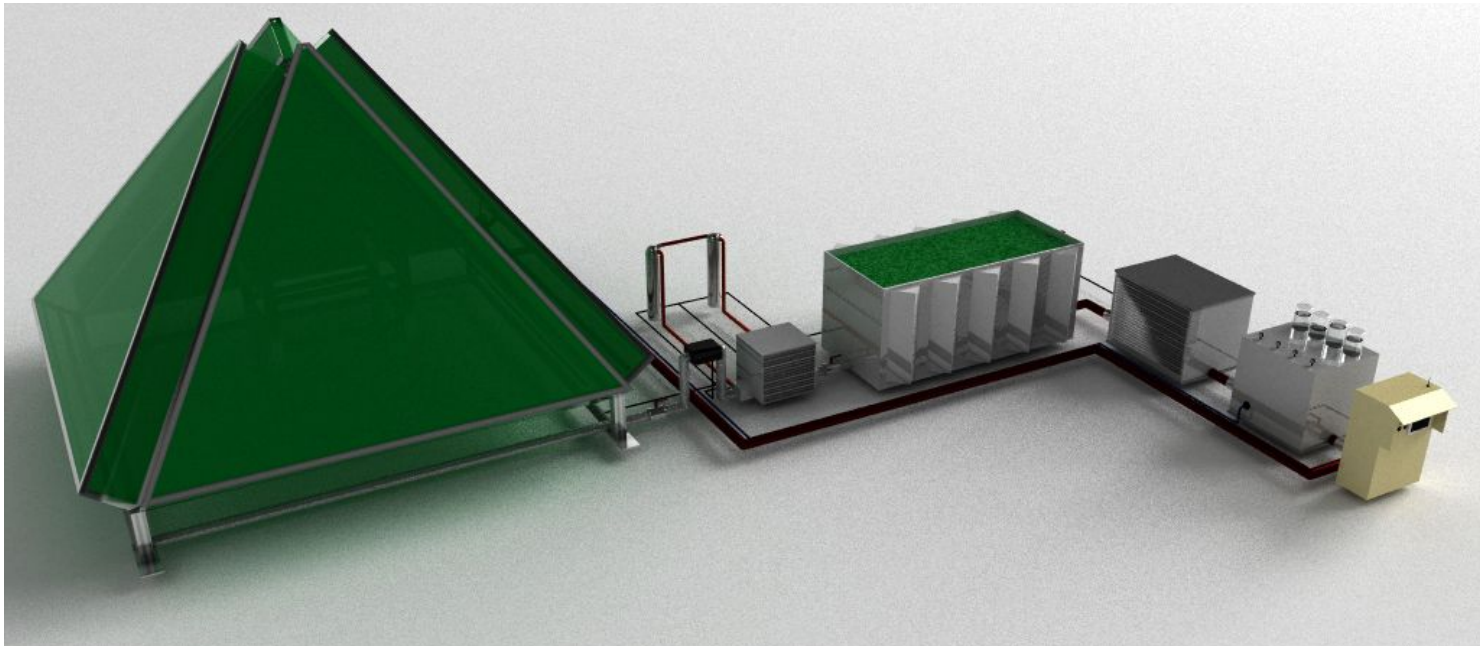

Embedded Pyramid Photobioreactor System Parts

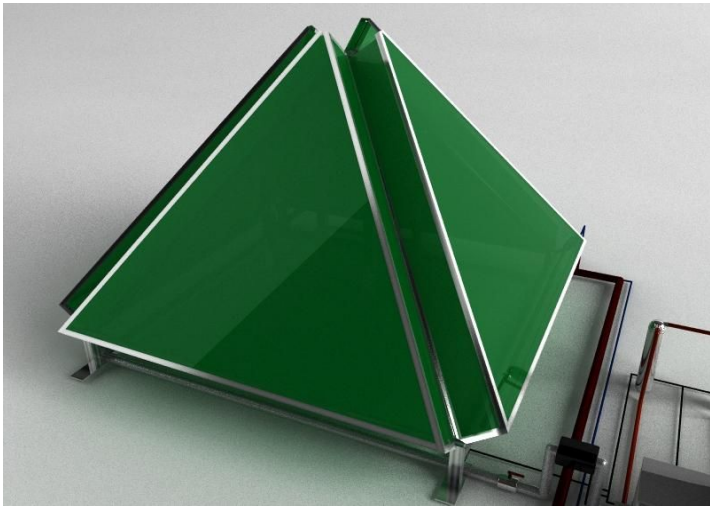

- Pyramid body
- Backlights (Led/Floresant)
- Control circuit
- Control panel
- Circulation pump
- Air pump
- Harvest pump
- 4 ways gas input
- O₂, CO₂, N_x valve
- Nutrients input
- Sterilization tank (UV)
- Circulation tank
- Algae filter
- Laser algae counter
- Starter chemicals
- Culture
- pH-meter
- CO₂ meter
- Temp-meter
- Circulation-meter
- Light sensor
- Conductivity sensor
- Heater
- Dehumiditer
- Control software
- Connectors & hoses
- Cooler

Pyramid Photobioreactor

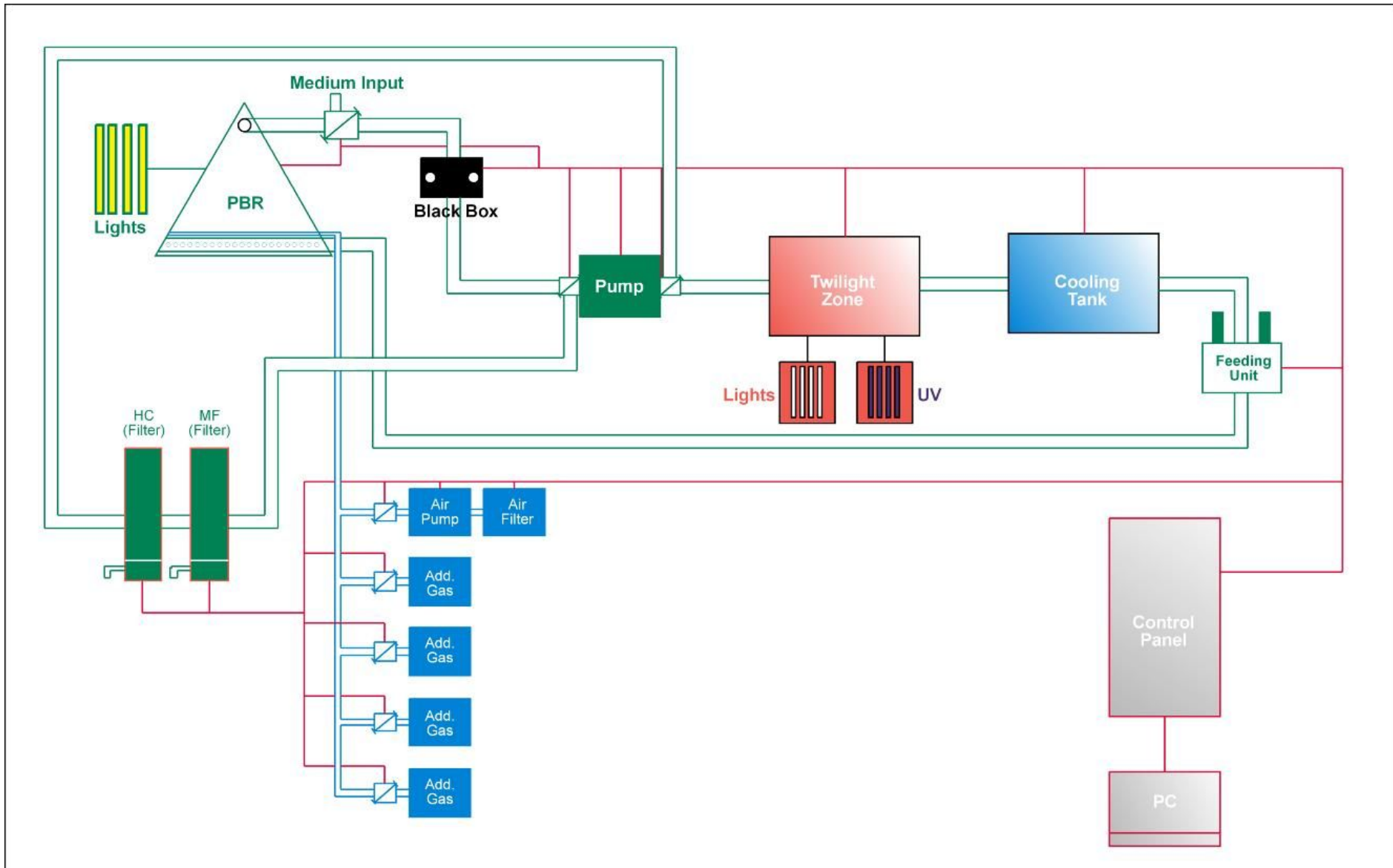

- 1-Pyramid Body
- 2-Black Box
- 3-Medium Pump
- 4-Twilight Zone Tank
- 5-Mid-Illumunating
- 6-UV Lamps
- 7-Cooling Unit
- 8-Feeding Unit
- 9-Control Panel
- 10-Harvest Filters

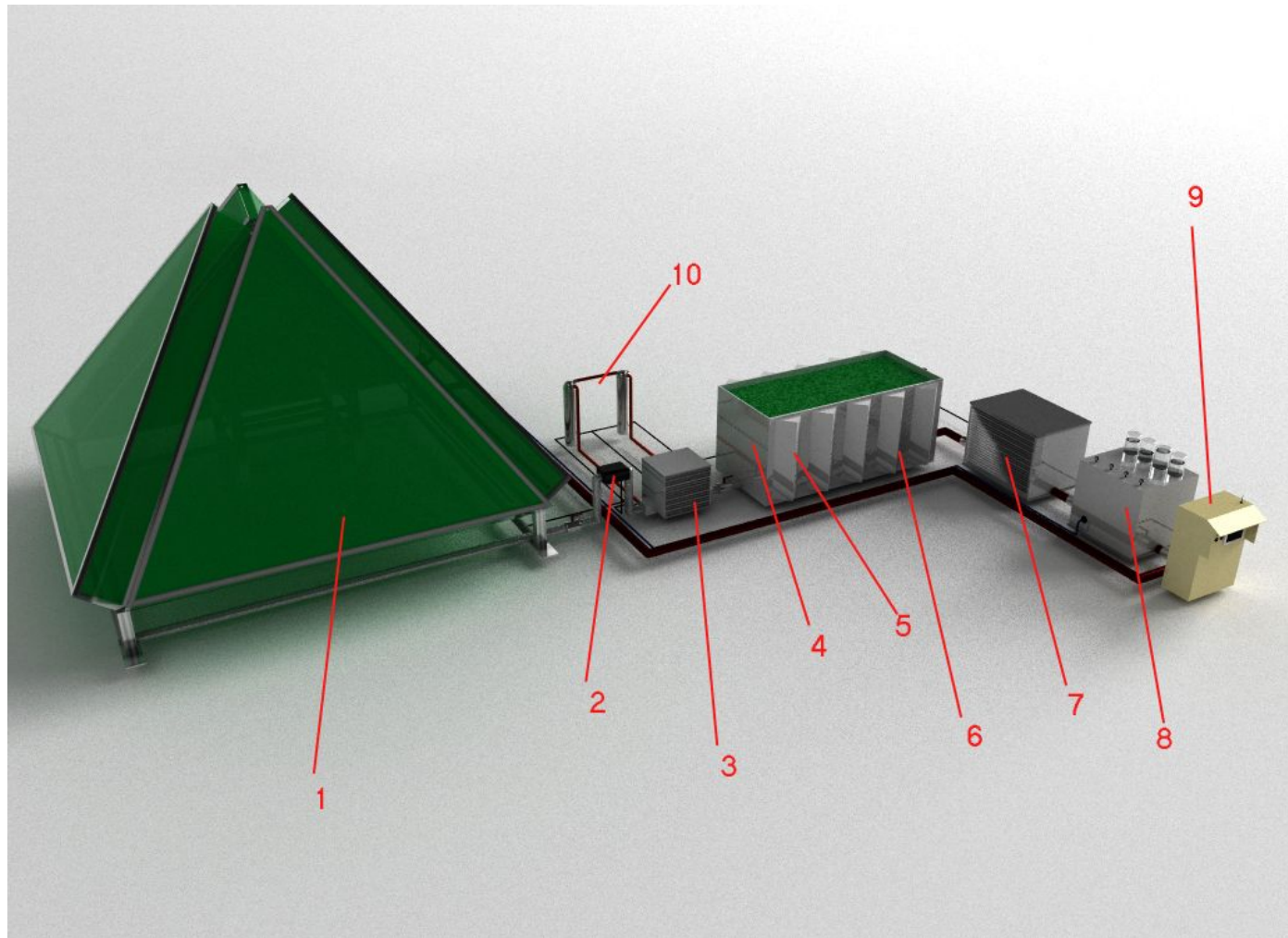

Comparision Chart of Most Popular PBRs & Ponds

	Open Pond	Closed Pond	Tubular Systems	Plastic Bag Systems	Well System	Pyramid Photobioreactor System
Water Media (tons)	100					
Area Requirement (m2)	250	250	1200	1200	25	60
Daily Production (kg dry wt.)	35	35	80	60	90	145
Areal Productivity (kg/m2/day)	0,14	0,14	0,066	0,05	3,6	2,416
Contamination Risk	+++++	+++	+	+	++	+
Evaporation Losses	+++++	++++	+	++	+++	+
Energy Requirement	+++	++	++++	+++	++	+
Overheating Potential	+++++	+++++	++++	++	+	++
Staff Requirement	+++++	+++	++	++	++	+
Maintance Costs	+++++	++++	+++	+++	+++	++
Periodic Maintance Requirement	+++++	+++++	++	+++	+++	+
Irreversible System Faults	+++++	++++	+	++	++	+
Microbiological Safety	+	++	+++++	+++	++	+++++
Air Cleaning Capacity	+	+	+++	++	++	+++++
Waste Gas Use Capacity	+	++	++++	++	++++	+++++
Productivity Stability (Season, temp, sunlight, etc.)	+	++	++++	+++	+++	+++++